

SIDE MARKER LAMP

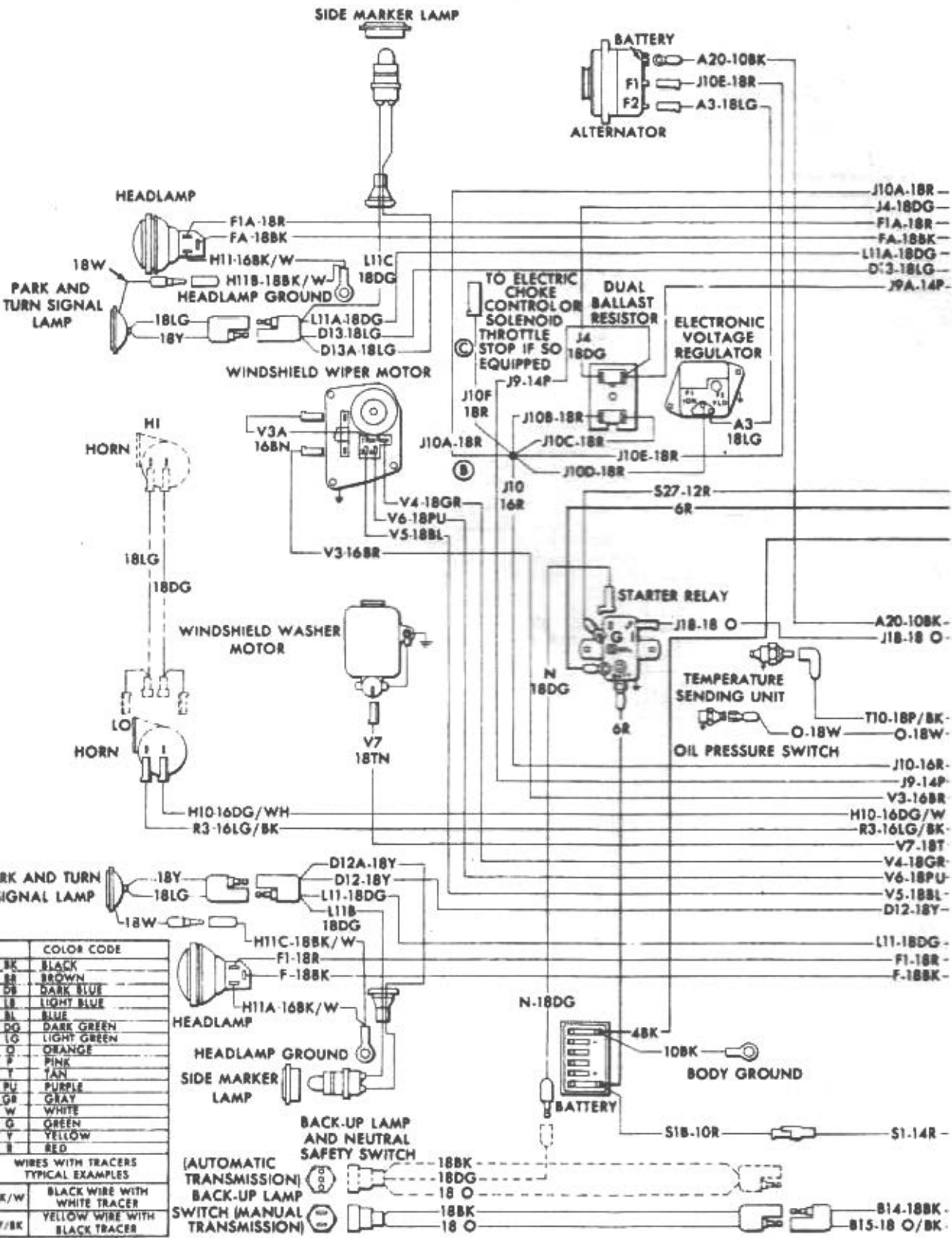

	COLOR CODE
BK	BLACK
BR	BROWN
DB	DARK BLUE
LB	LIGHT BLUE
BL	BLUE
DG	DARK GREEN
LG	LIGHT GREEN
O	ORANGE
P	PINK
T	TAN
PU	PURPLE
GR	GRAY
W	WHITE
G	GREEN
Y	YELLOW
R	RED
WIRES WITH TRACERS TYPICAL EXAMPLES	
BK/W	BLACK WIRE WITH WHITE TRACER
Y/BK	YELLOW WIRE WITH BLACK TRACER

Wiring diagram - 1971 through 1976 models (1977 and 1978 models similar) (1 of 6)
 Front lights, charging system, starter relay, engine switches

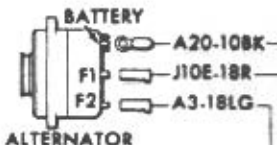
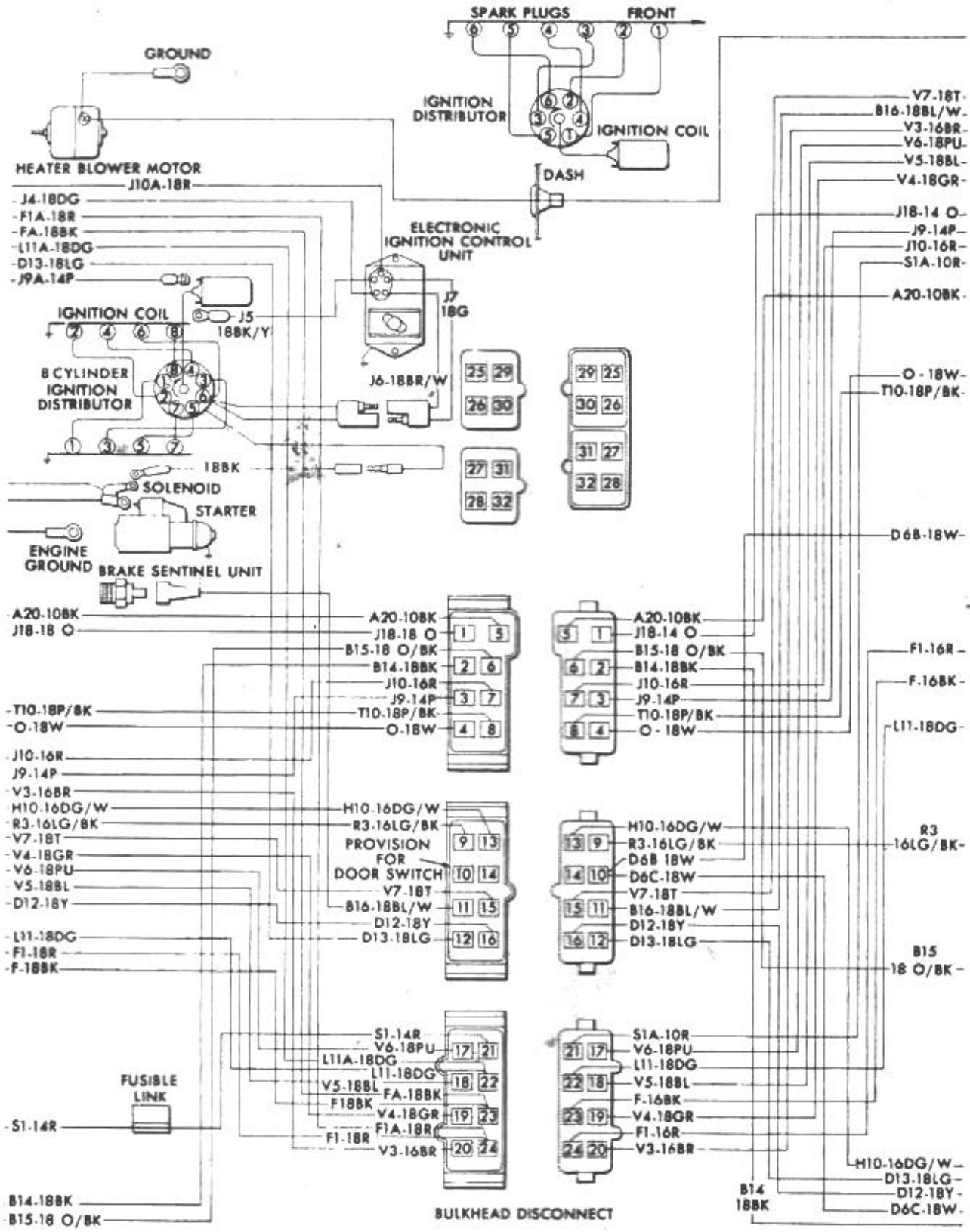

Wiring diagram - 1971 through 1976 models (1977 and 1978 models similar) (2 of 6)
Heater, ignition distributor, bulkhead disconnect block

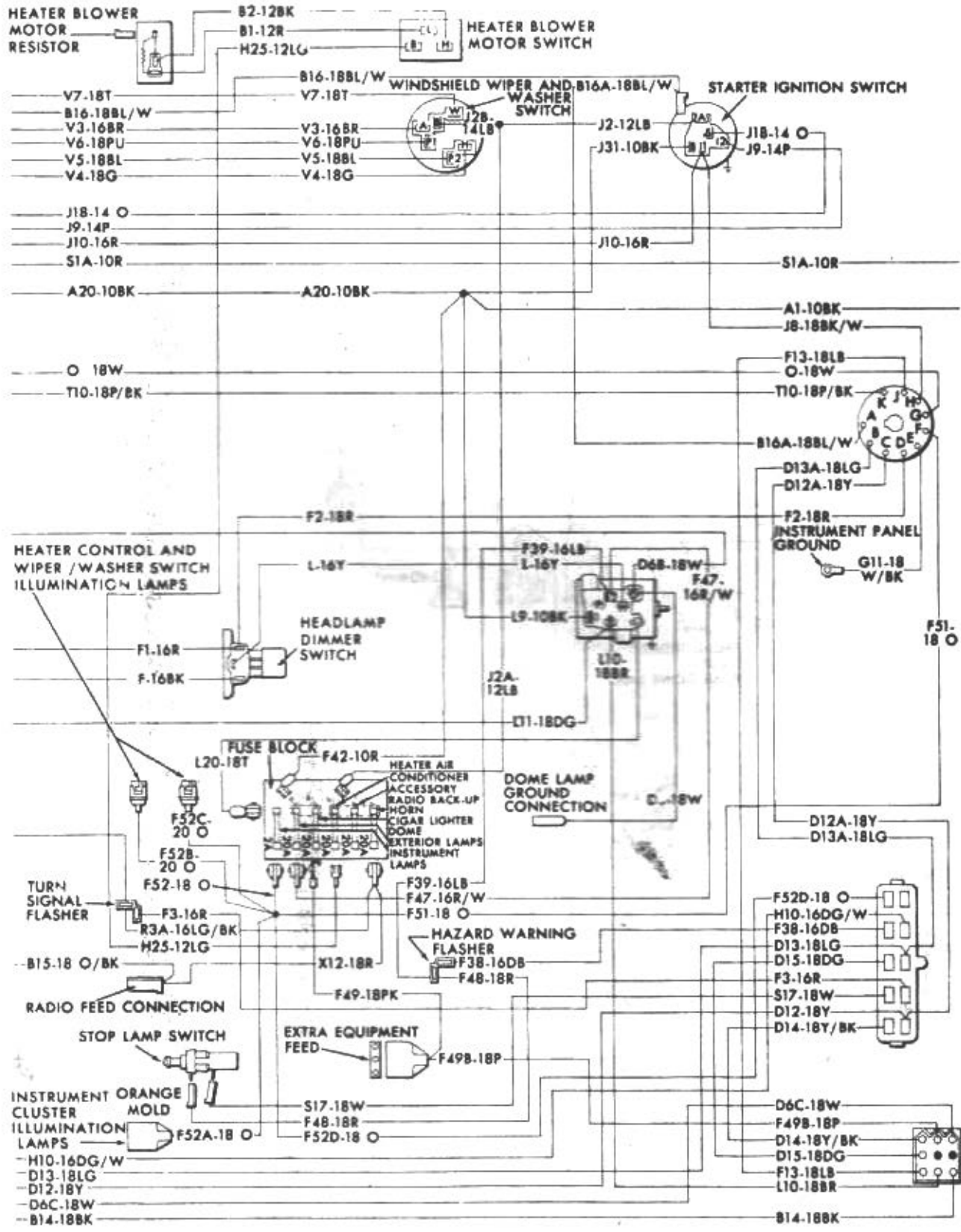

Wiring diagram - 1971 through 1976 models (1977 and 1978 models similar) (3 of 6)
 Heater, wiper/washer, ignition switch, instrument lights

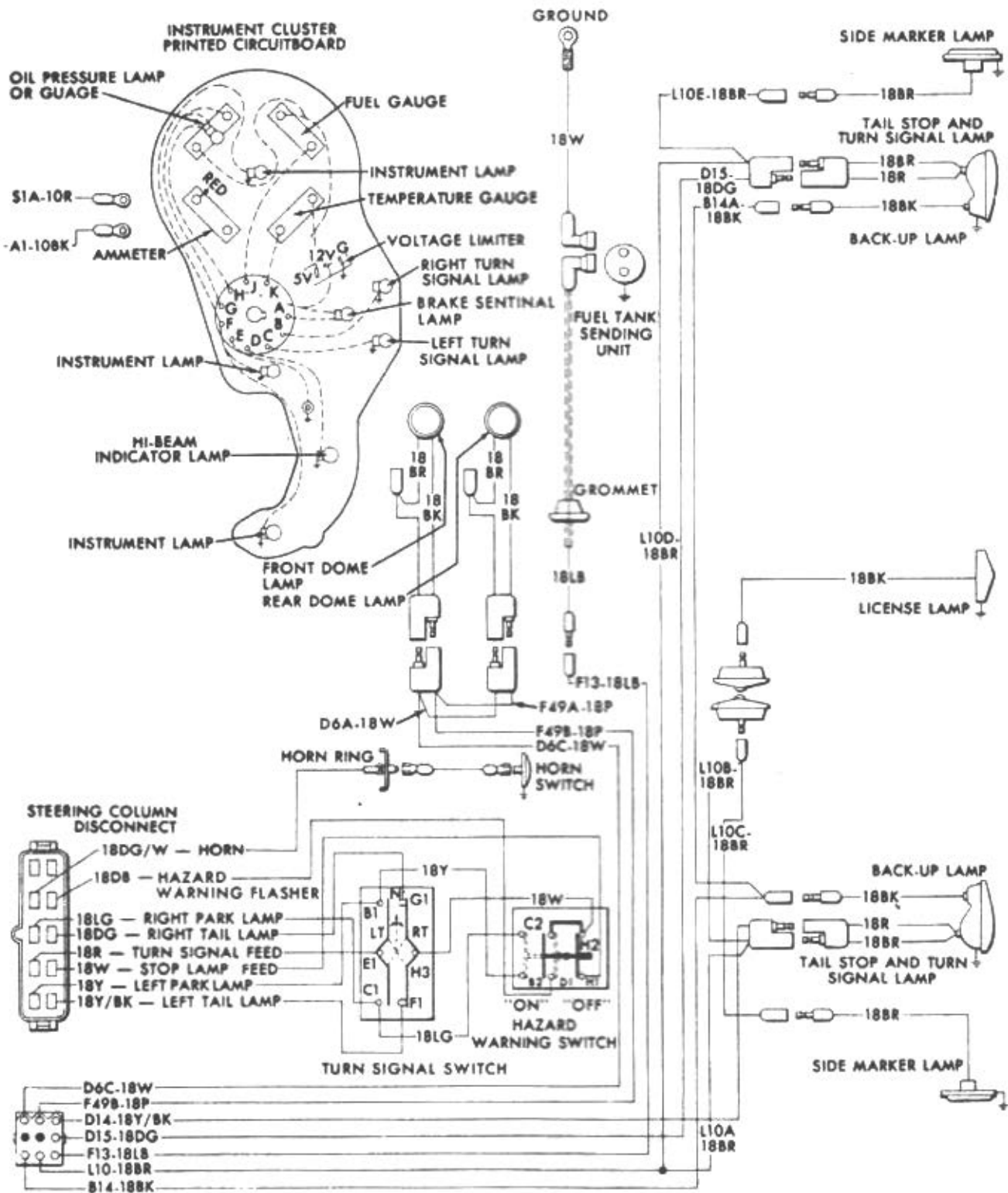

Wiring diagram - 1971 through 1976 models (1977 and 1978 models similar) (4 of 6)

Instrument cluster, steering column, rear lights

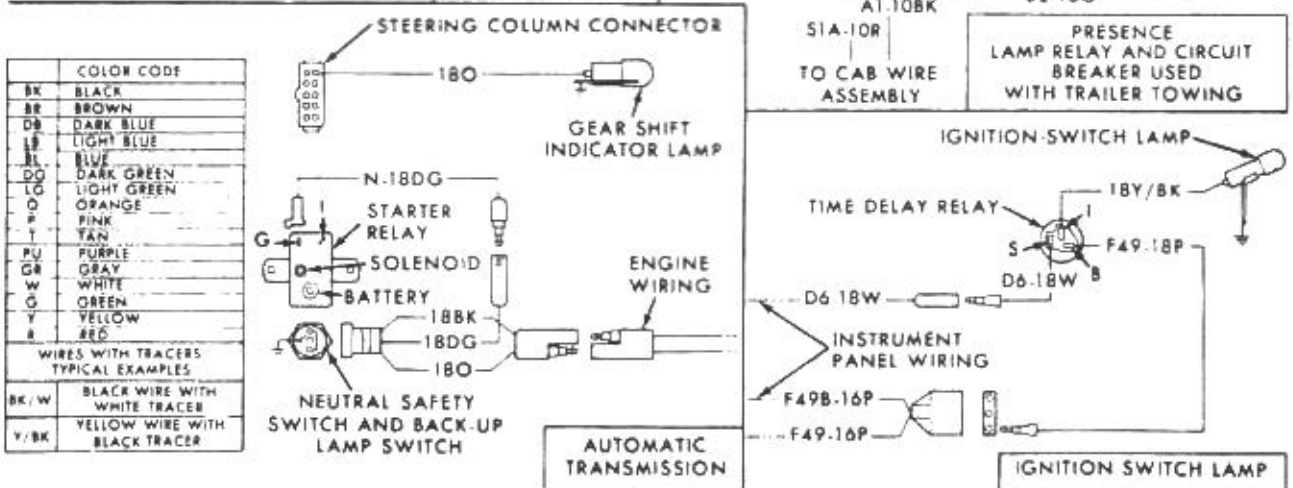
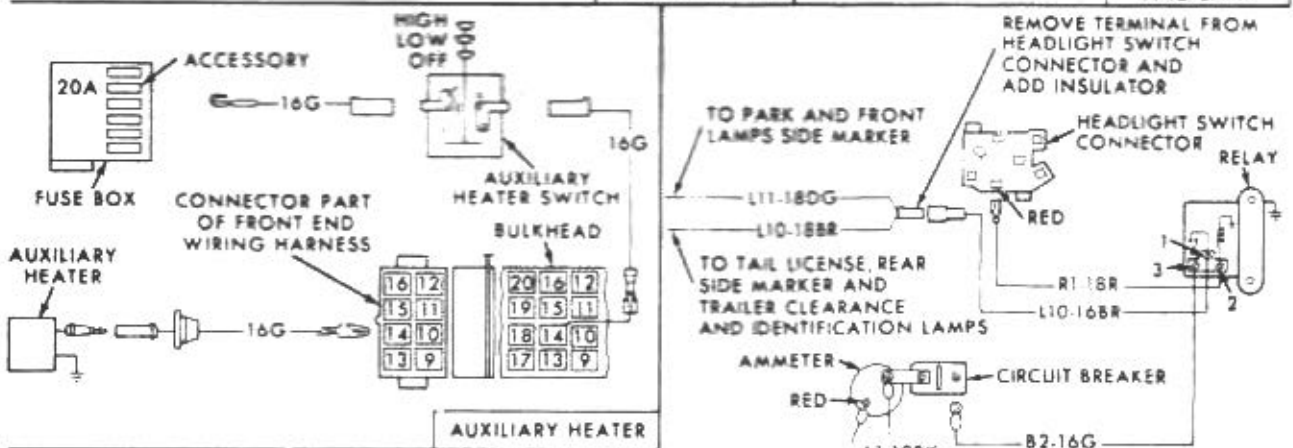
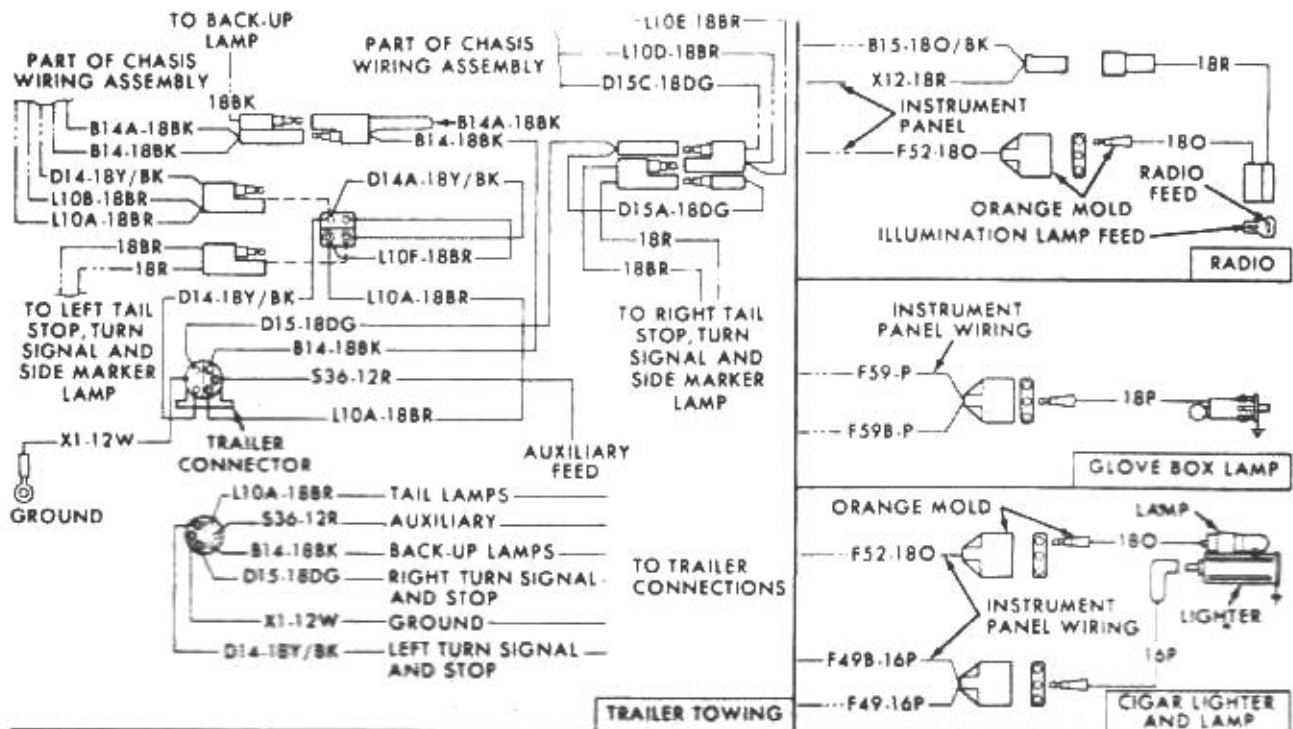

	COLOR CODE
BK	BLACK
BR	BROWN
DB	DARK BLUE
LB	LIGHT BLUE
BL	BLUE
LG	DARK GREEN
LO	LIGHT GREEN
O	ORANGE
P	PINK
T	TAN
PU	PURPLE
GR	GRAY
W	WHITE
G	GREEN
Y	YELLOW
R	RED
WIRES WITH TRACERS TYPICAL EXAMPLES	
BK/W	BLACK WIRE WITH WHITE TRACER
Y/BK	YELLOW WIRE WITH BLACK TRACER

Wiring diagram - 1971 through 1976 models (1977 and 1978 models similar) (5 of 6)
Auxiliary wiring systems

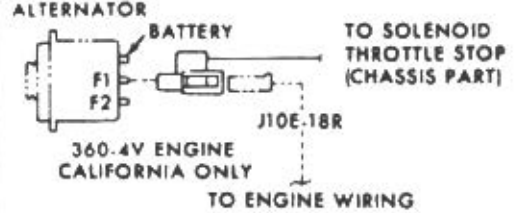
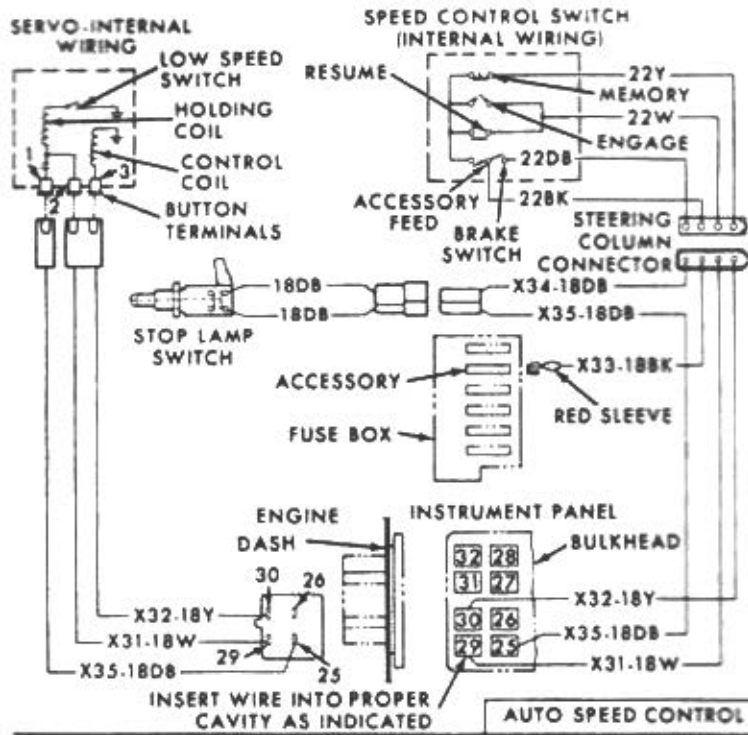

WIRING DIAGRAM ELECTRIC CHOKE CONTROL UNIT AND SOLENOID THROTTLE STOP

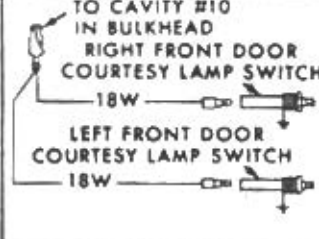
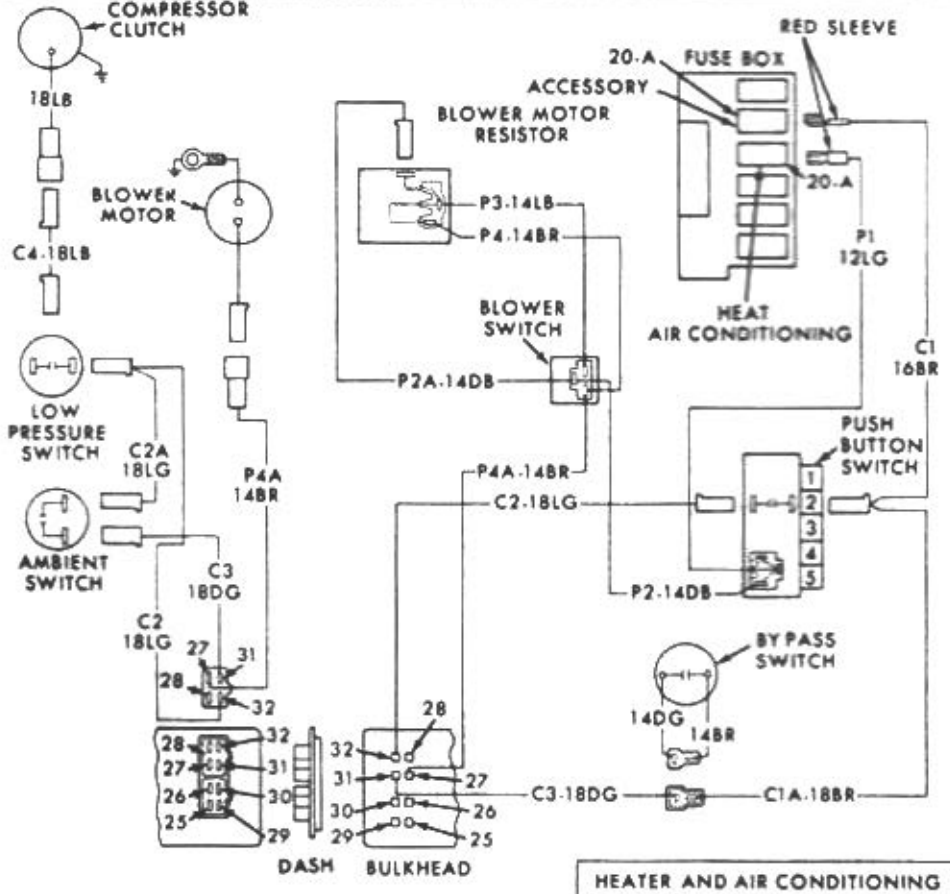
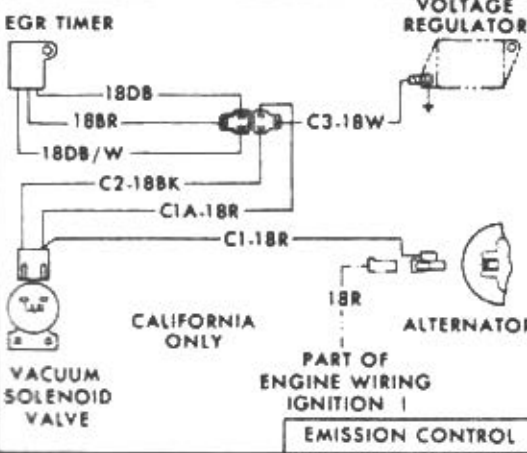

FRONT DOOR COURTESY LAMP SWITCHES

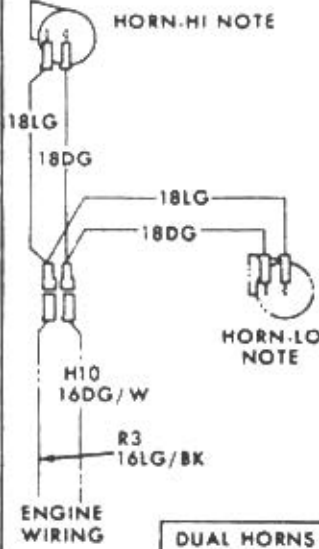

DUAL HORNS

Wiring diagram - 1971 through 1976 models (1977 and 1978 models similar) (6 of 6)

Auxiliary wiring systems

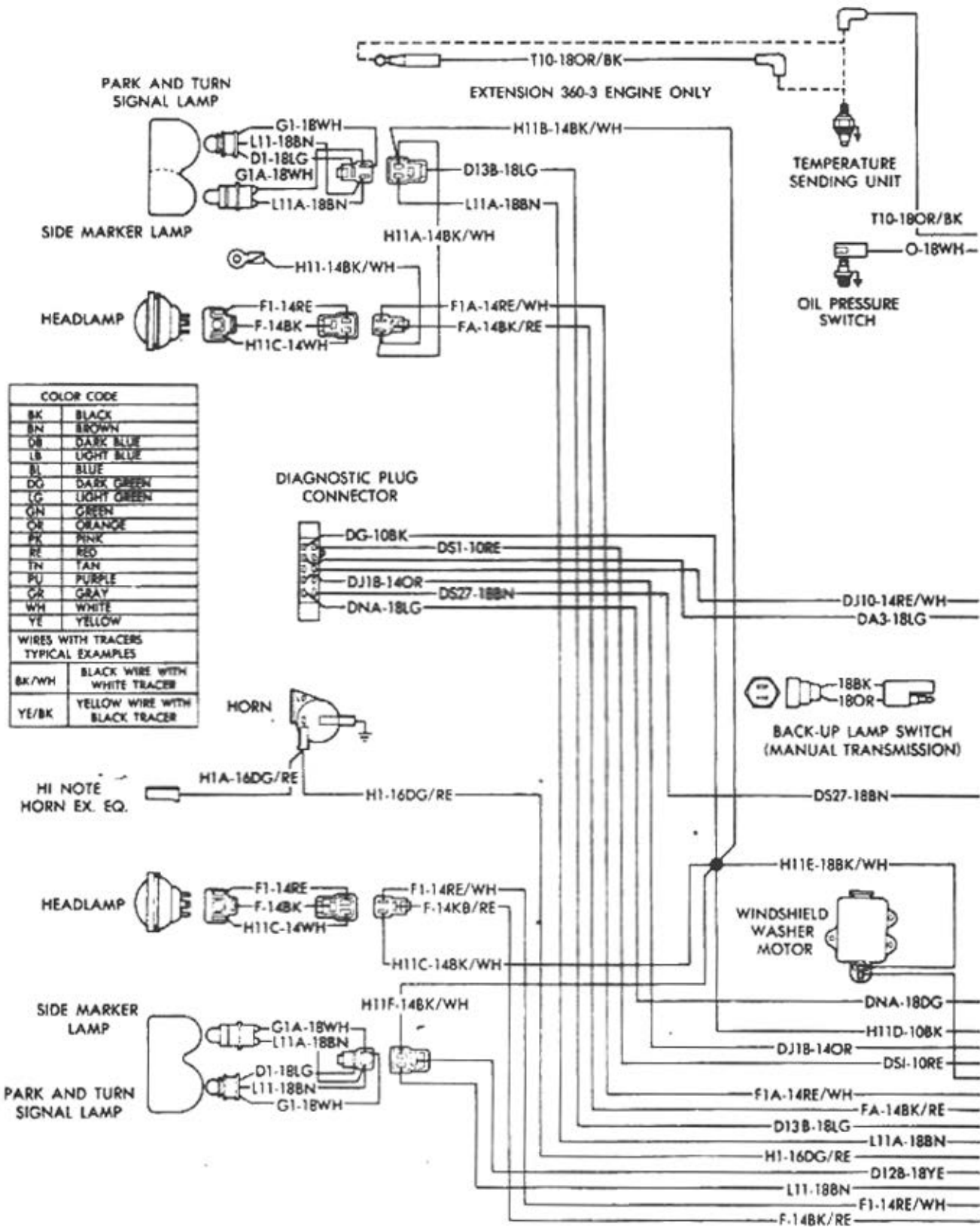

Wiring diagram - 1979 through 1984 models (1 of 6)

Front lights, horn, engine switches

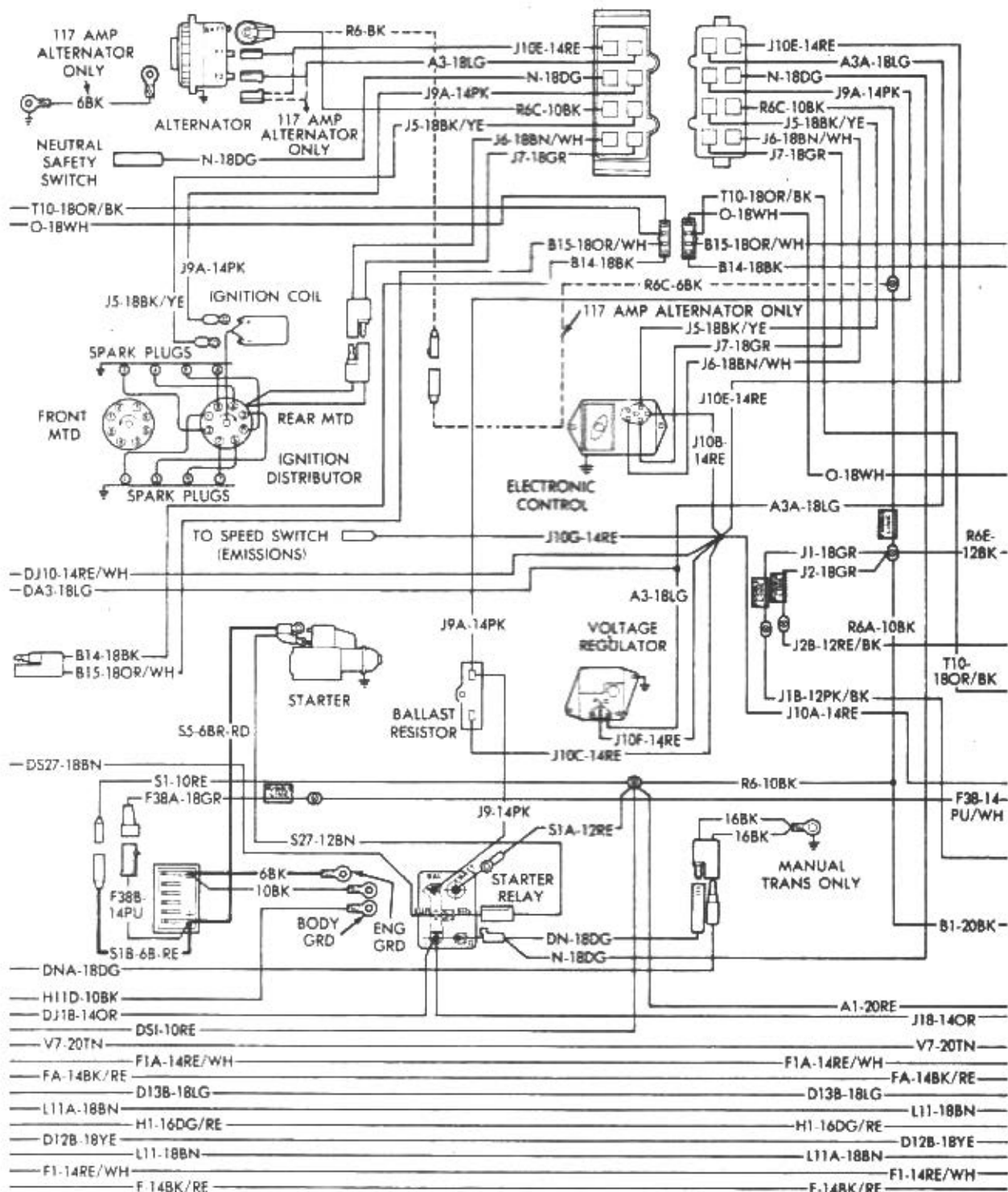

Wiring diagram - 1979 through 1984 models (2 of 6)
Charging system, ignition distributor, starting system

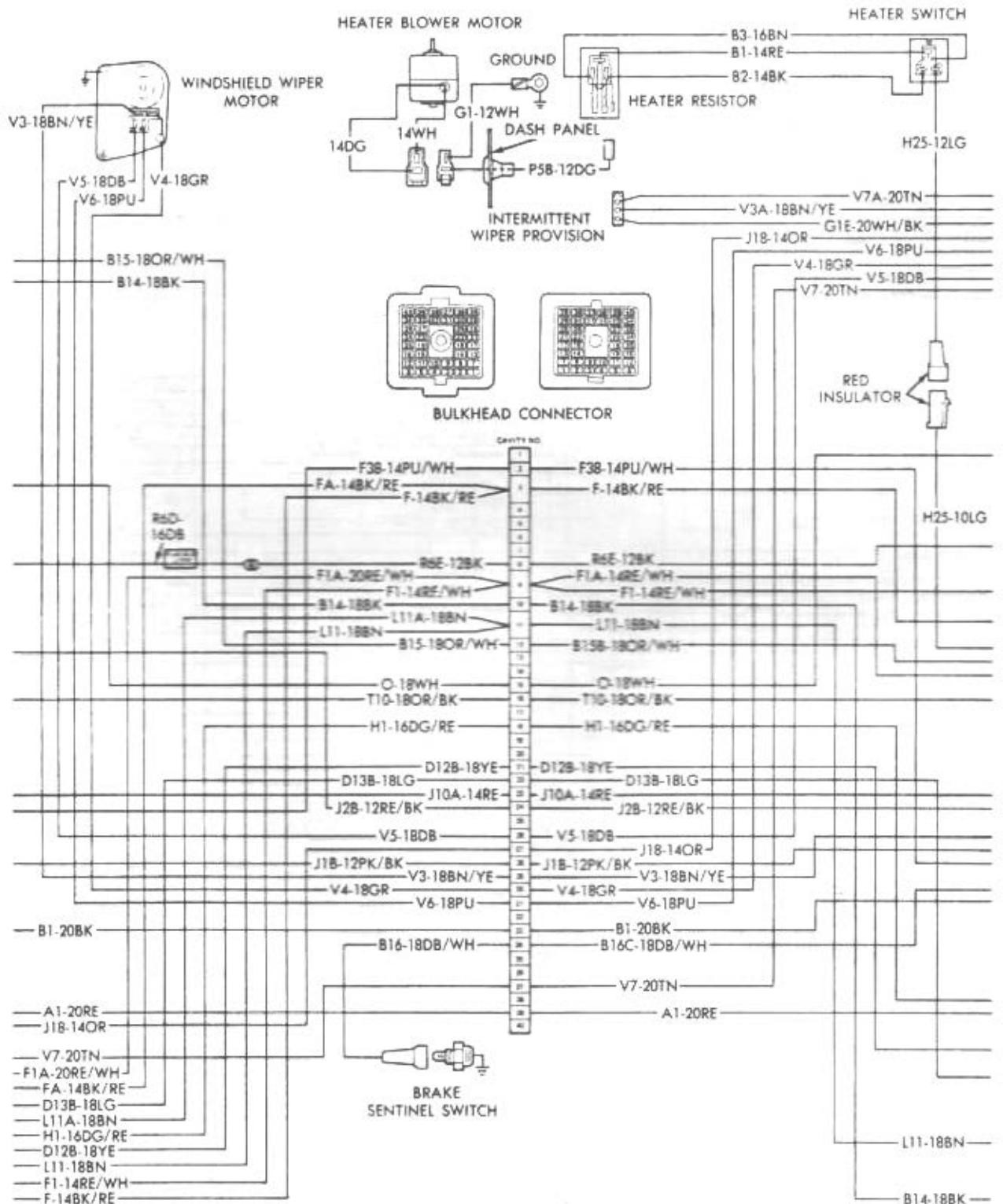

Wiring diagram - 1979 through 1984 models (3 of 6)
Heater, wiper motor, bulkhead disconnect block

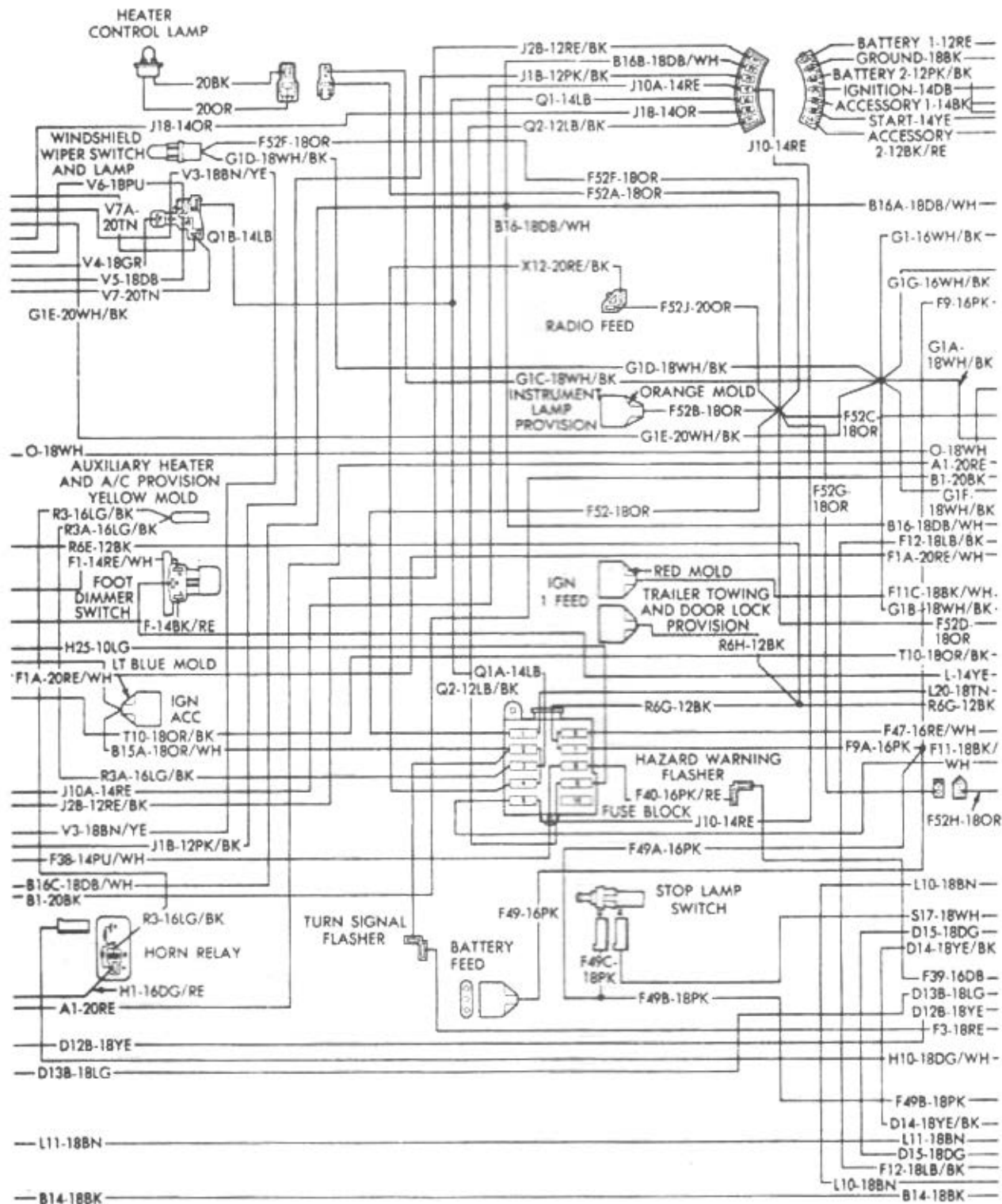

Wiring diagram - 1979 through 1984 models (4 of 6)
 Fuse block, ignition switch, auxiliary wiring systems

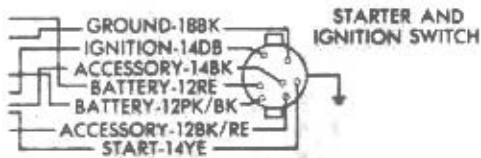

INSTRUMENT CLUSTER PRINTED CIRCUIT BOARD

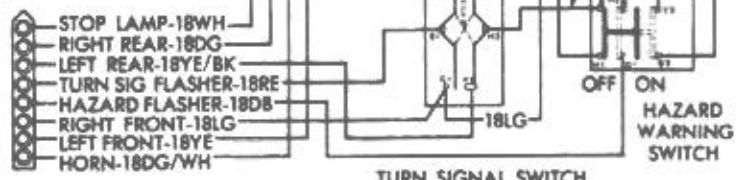
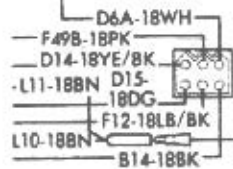
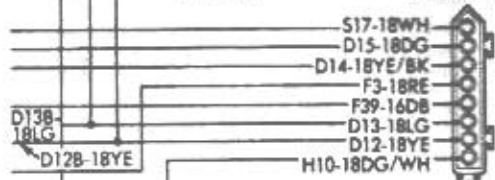
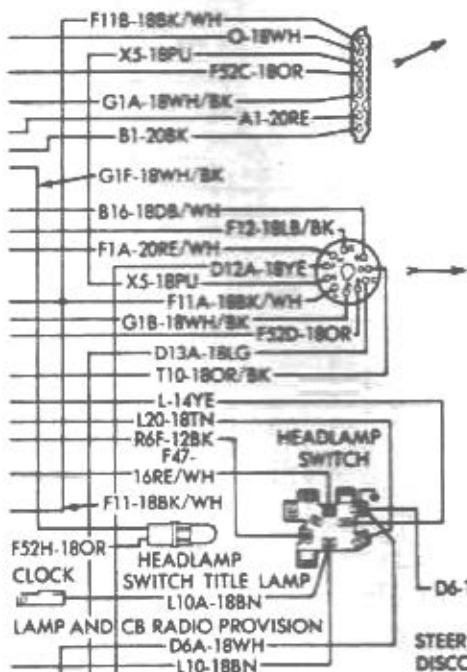
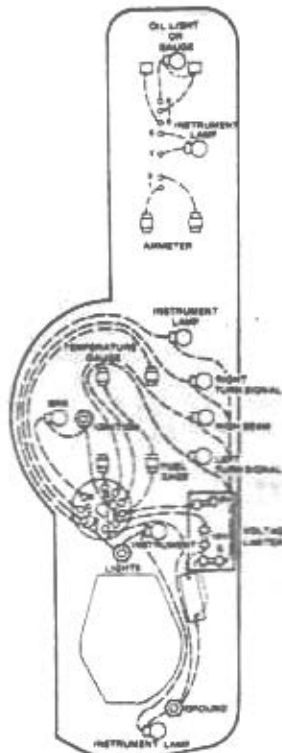

Wiring diagram - 1979 through 1984 models (5 of 6)
Instrument cluster and switches

* NOTE
 100A- STANDARD ALTERNATOR (50 AMP)
 B 5A- 100 AMP ALTERNATOR

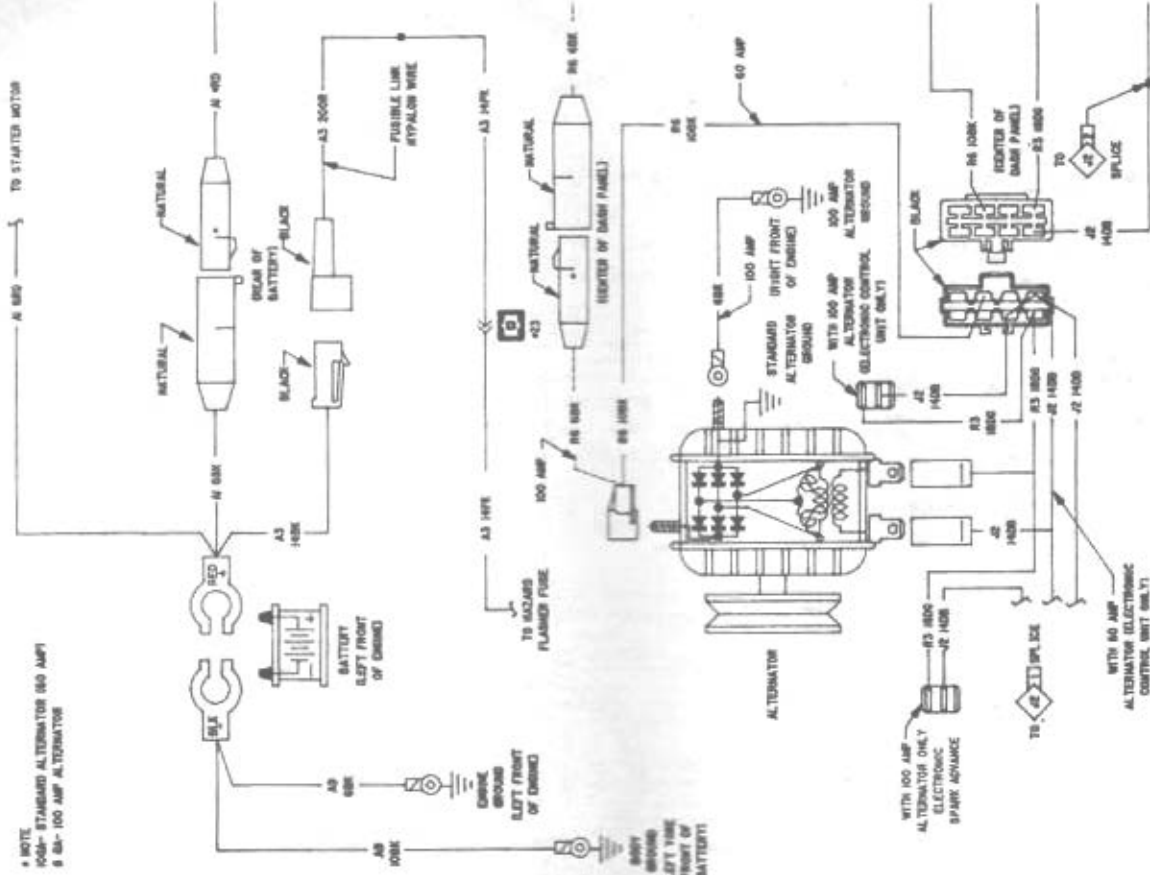

Wiring diagram - 1985 through 1987 models (1 of 11)
 Charging system

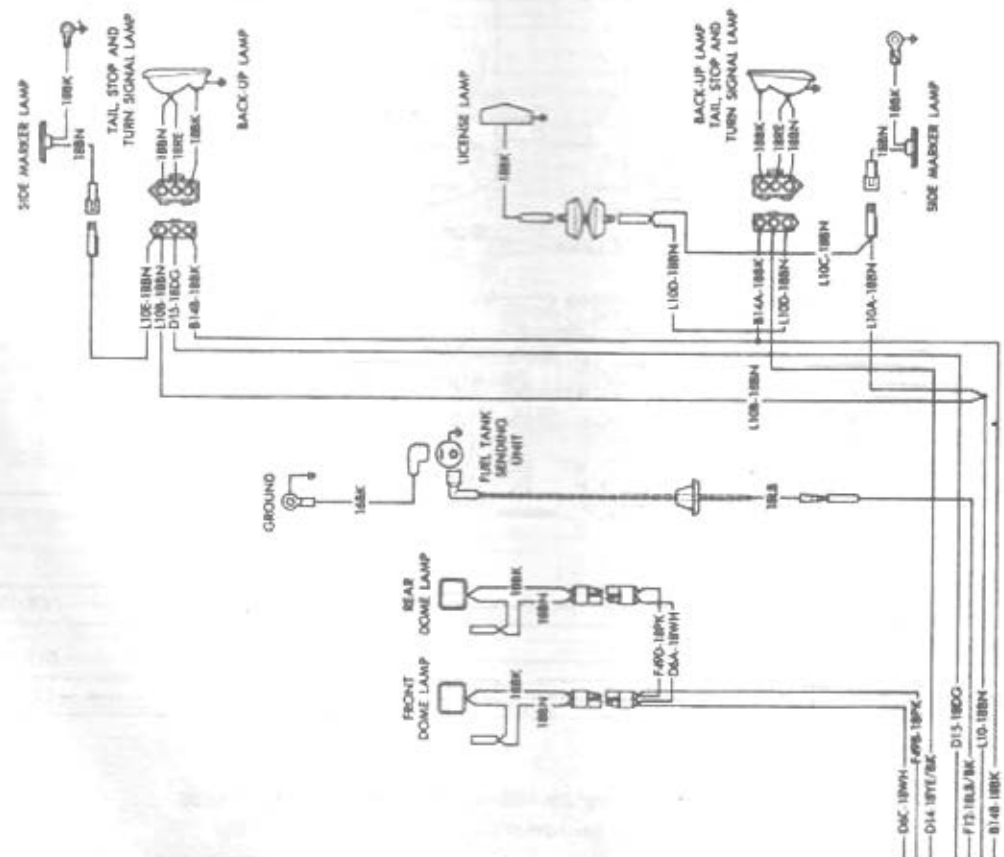

Wiring diagram - 1979 through 1984 models (6 of 6)
 Interior lights, fuel tank and rear lights

• NOTE
 106A- STANDARD ALTERNATOR (60 AMP)
 6 GA- 100 AMP ALTERNATOR

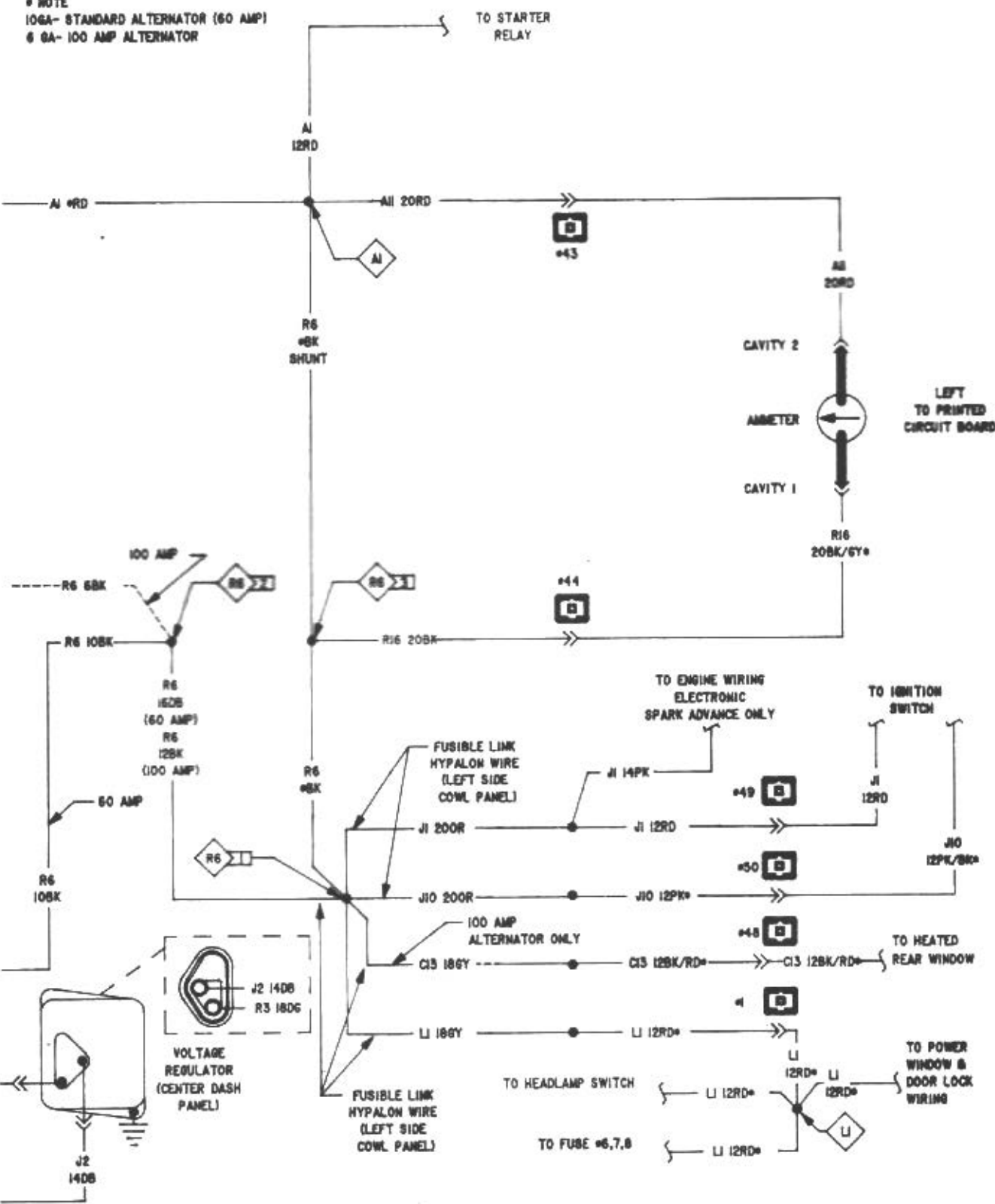

Wiring diagram - 1985 through 1987 models (2 of 11)
 Charging system

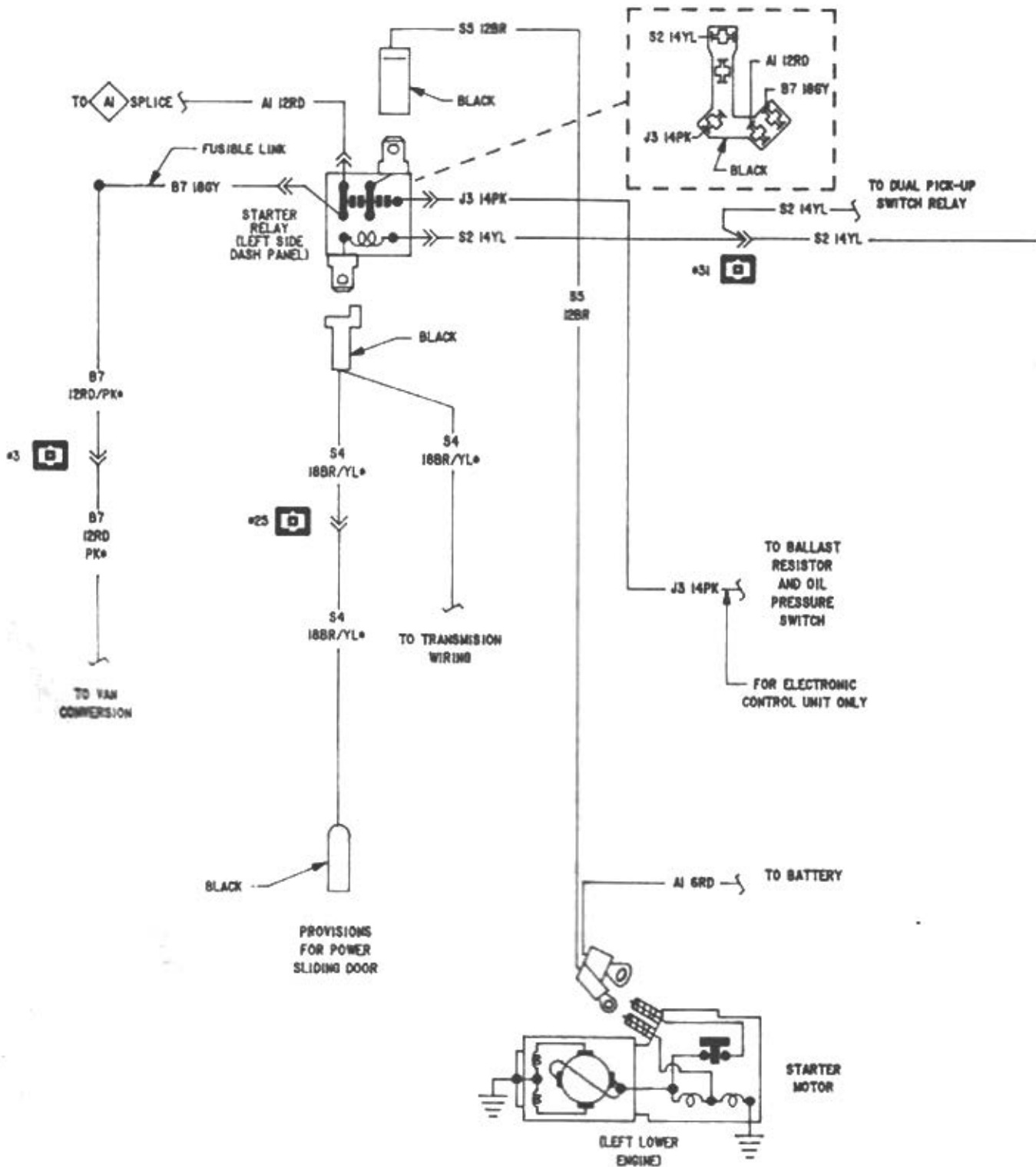

Wiring diagram - 1985 through 1987 models (3 of 11)
Starting system

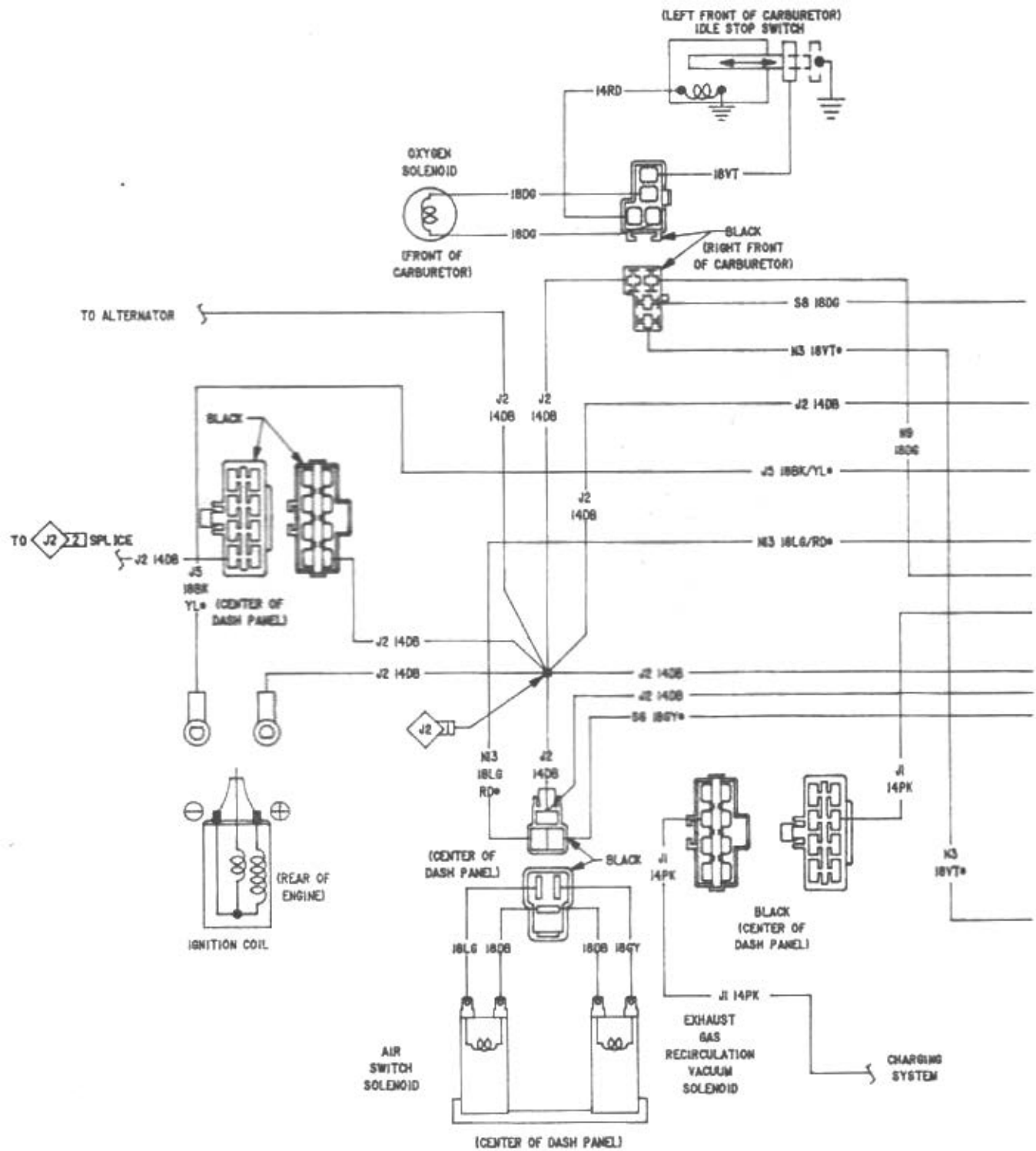

Wiring diagram - 1985 through 1987 models (4 of 11)

Ignition system - 318 V8

[OIL PRESSURE SWITCH
RIGHT SIDE OF ENGINE]

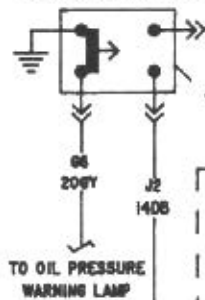

TO OIL PRESSURE
WARNING LAMP

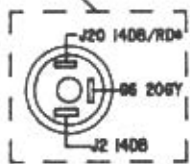

ELECTRIC CHOKE CONTROL

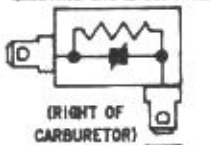

(RIGHT OF
CARBURETOR)

BLACK

BLACK



ELECTRIC CHOKE
HEATER
(RIGHT OF
CARBURETOR)

BLACK

(LEFT MOTOR
MOUNT)

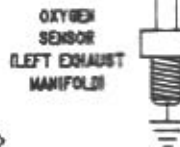

OXYGEN
SENSOR
(LEFT EXHAUST
MANIFOLD)

18BK

J9

NI 18BK

J9 12BK

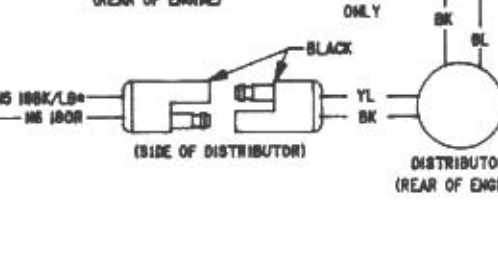
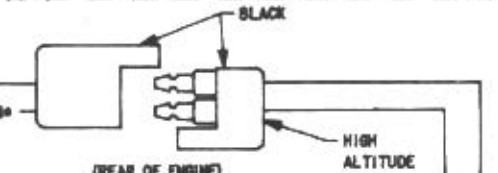
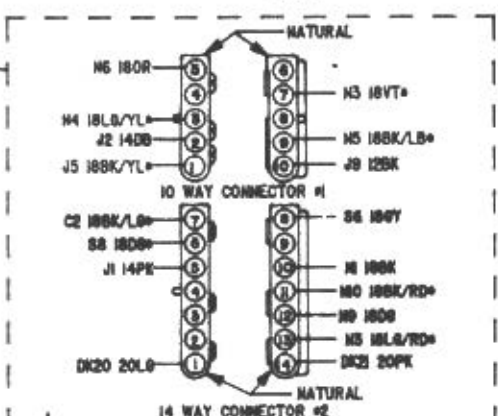
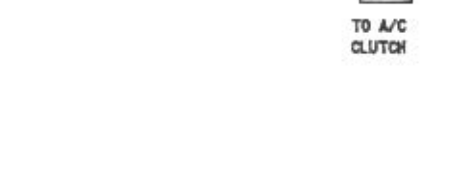
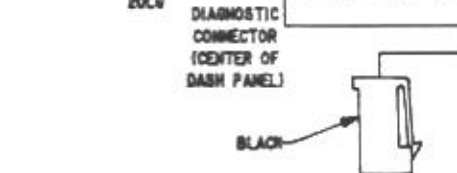
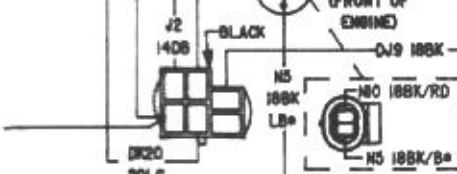
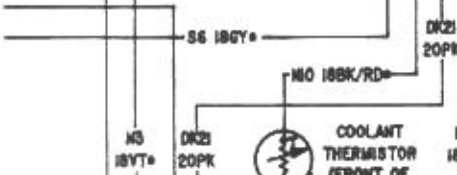
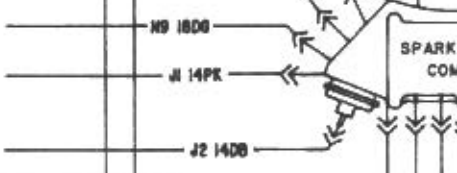
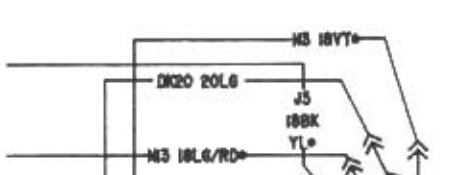
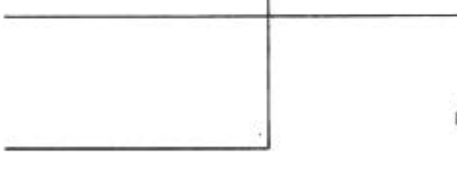

Wiring diagram - 1985 through 1987 models (5 of 11)
Ignition system - 318 V8

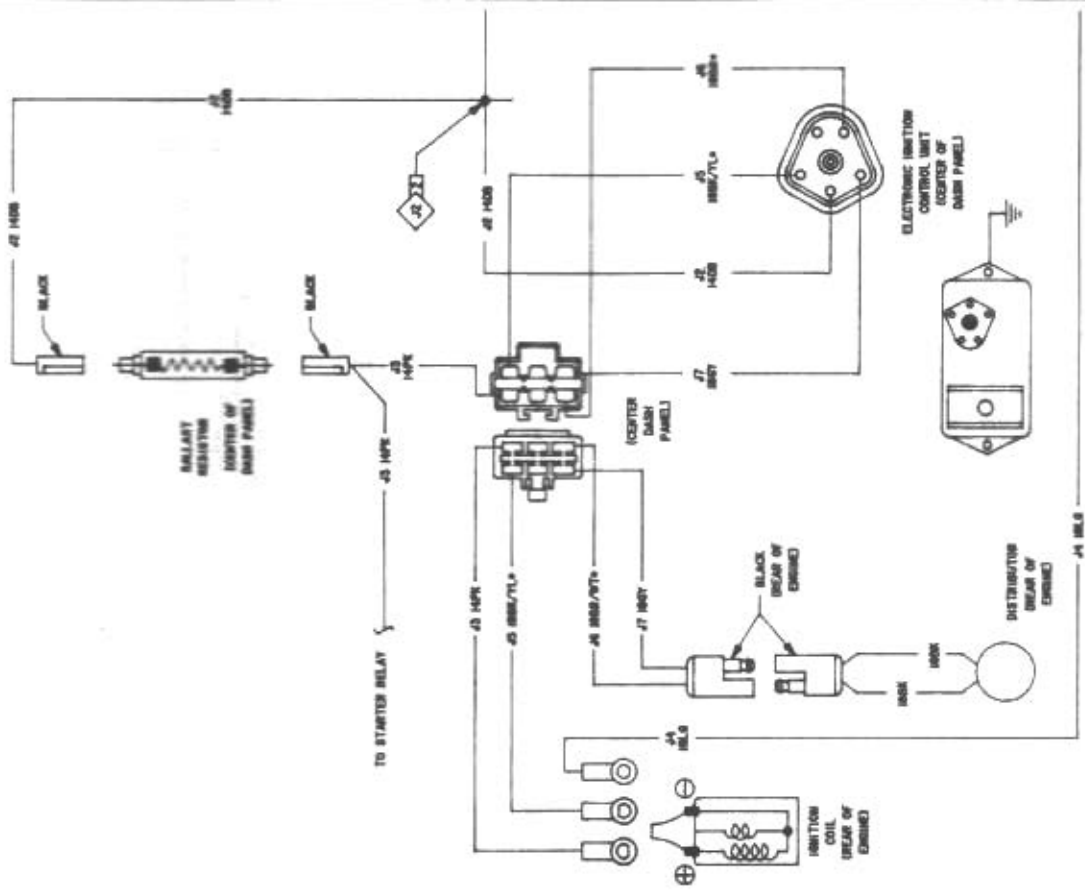

Wiring diagram - 1985 through 1987 models (6 of 11)
Electronic control unit - 318/360 V8

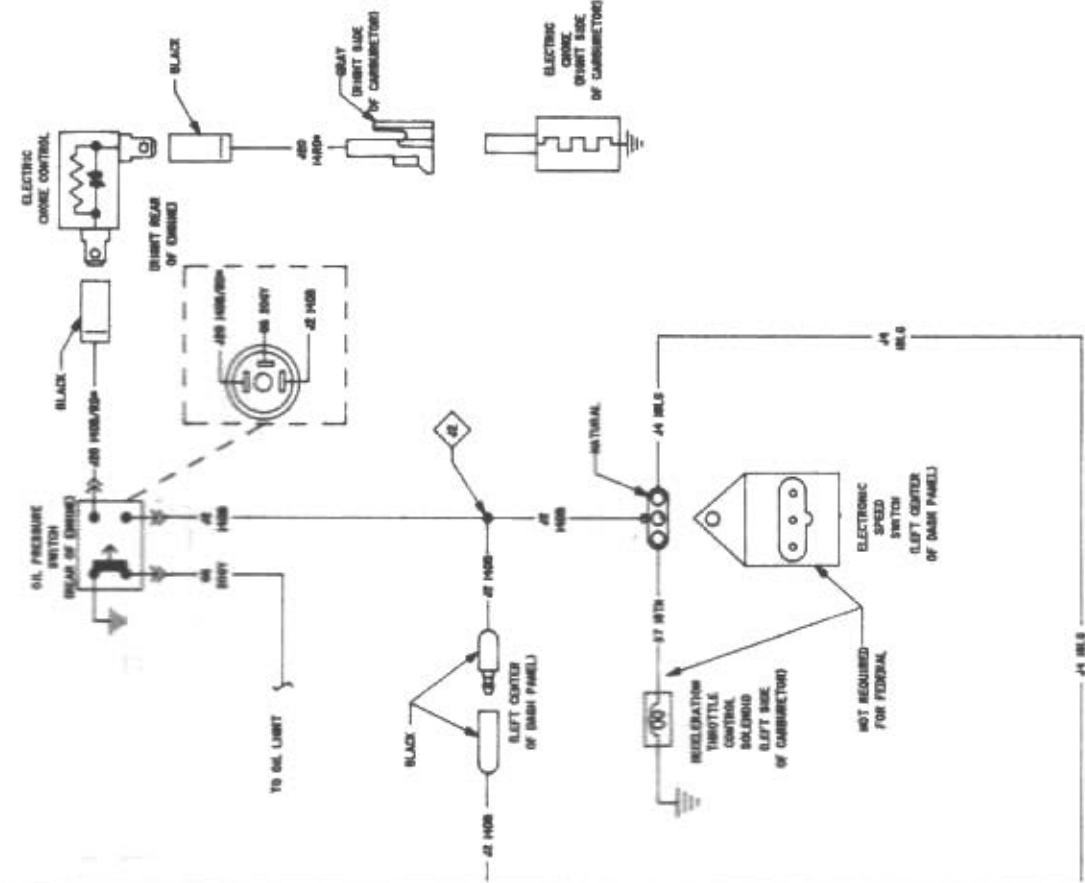

Wiring diagram - 1985 through 1987 models (7 of 11)
Electronic control unit - 318/360 V8

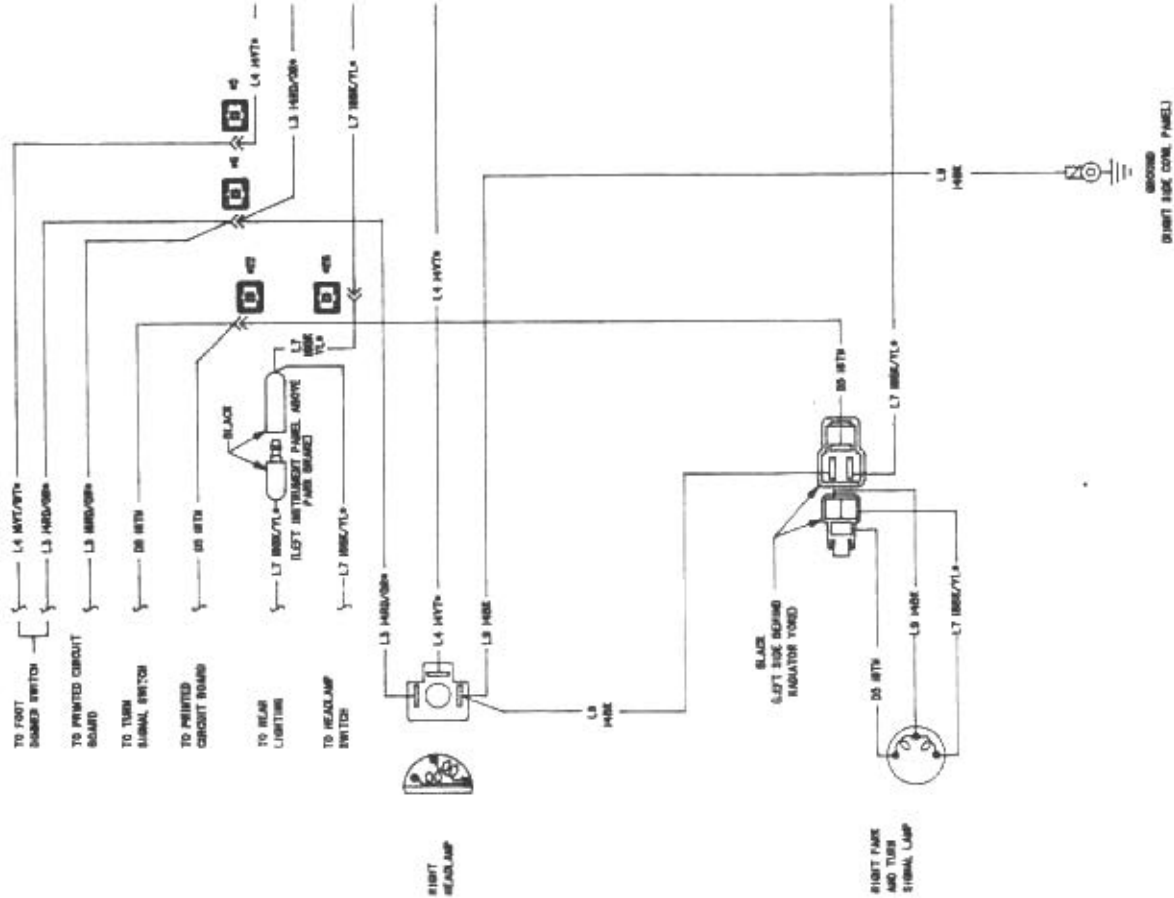

Wiring diagram - 1985 through 1987 models (8 of 11)
 Front lighting

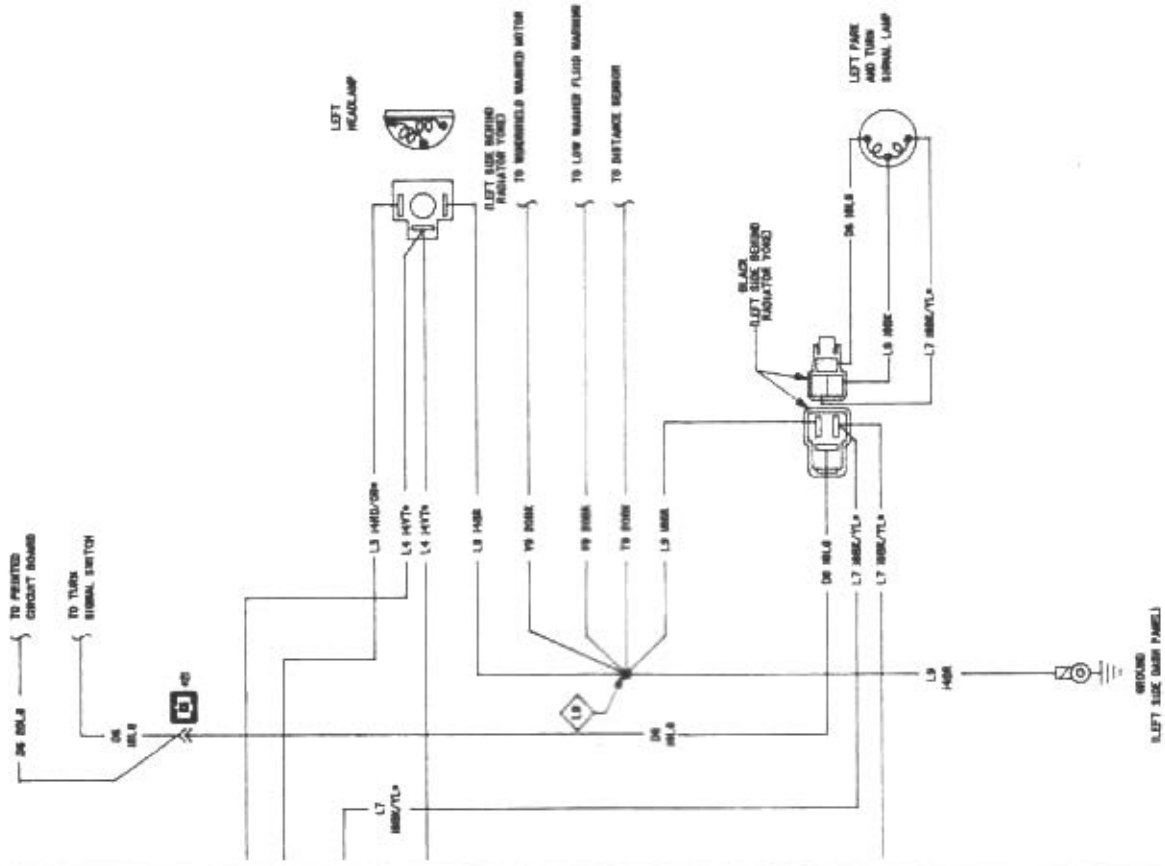

Wiring diagram - 1985 through 1987 models (9 of 11)
 Front lighting

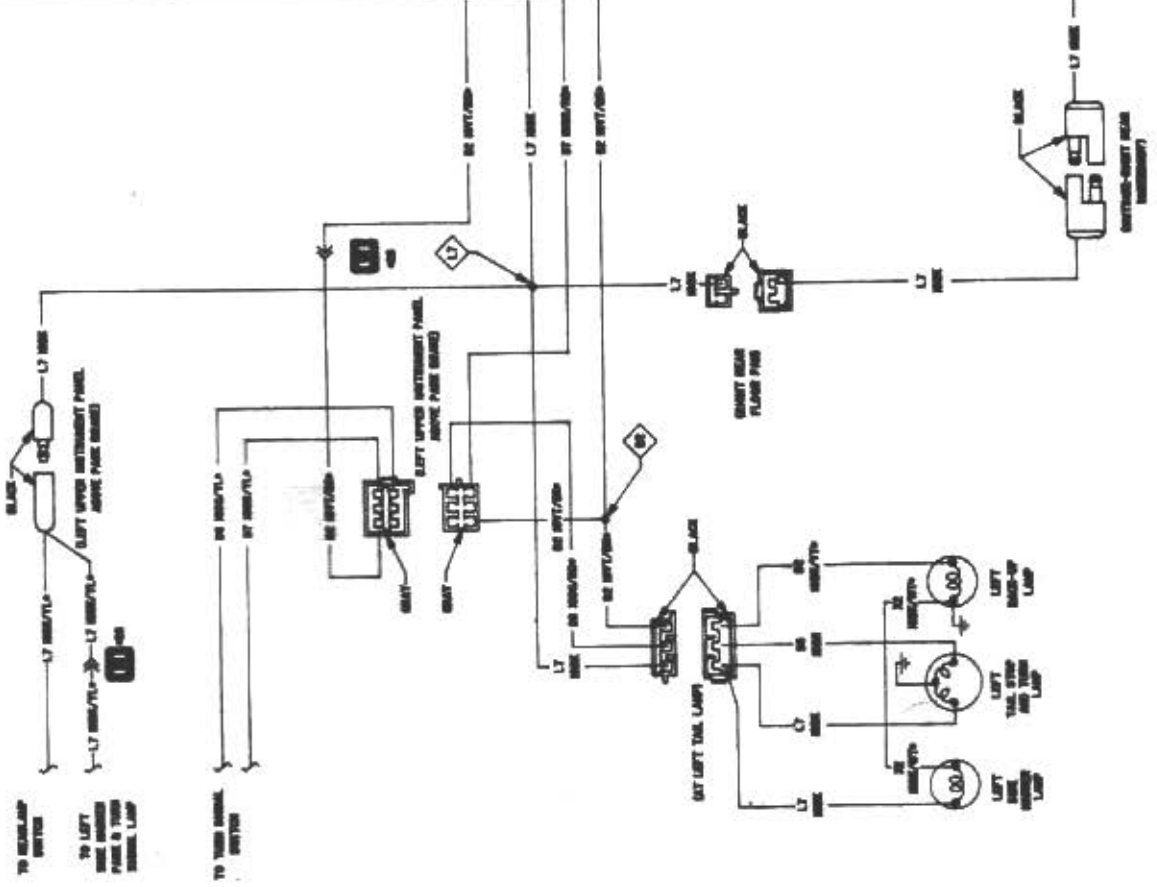

Wiring diagram - 1985 through 1987 models (10 of 11)
Rear lighting

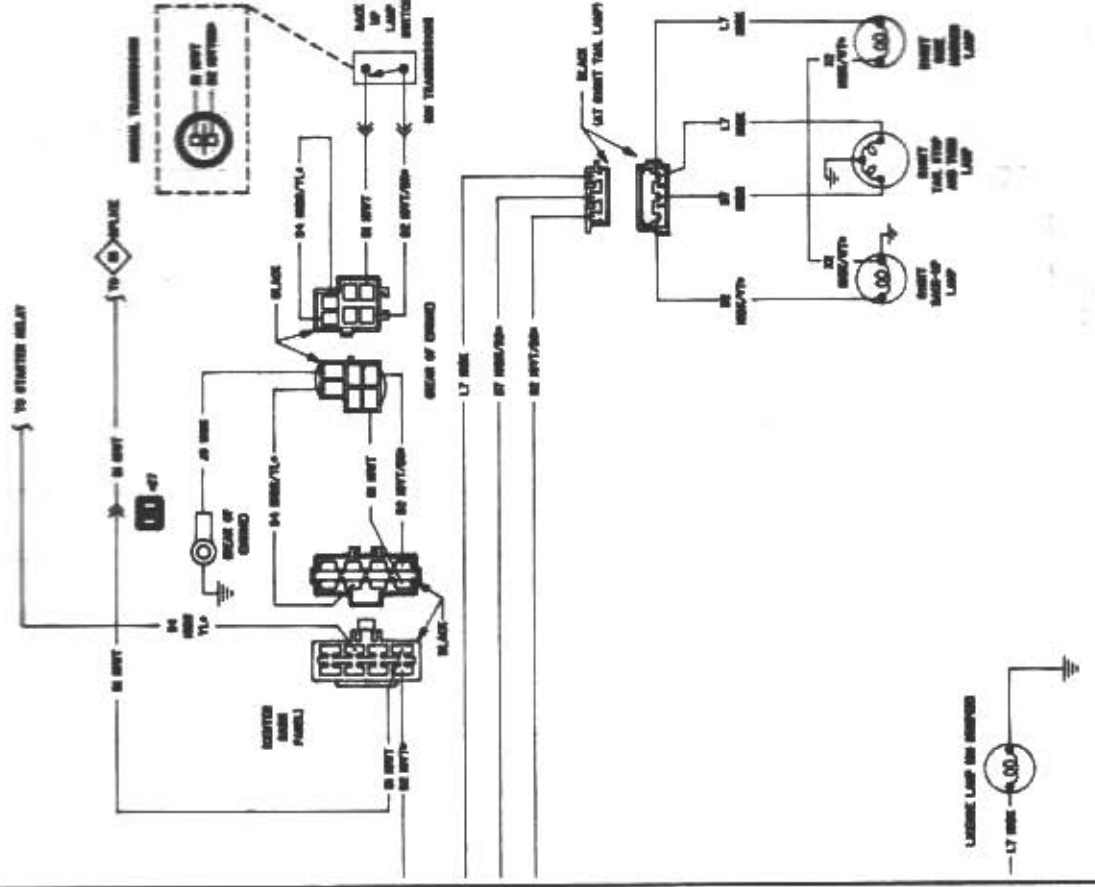

Wiring diagram - 1985 through 1987 models (11 of 11)
Rear lighting