

01-2140 Replacing radial shaft seals in front covers at top

Preceding work:
Follower at camshaft removed (01-2130)

A. Engine 119.96/97 with front cover installed

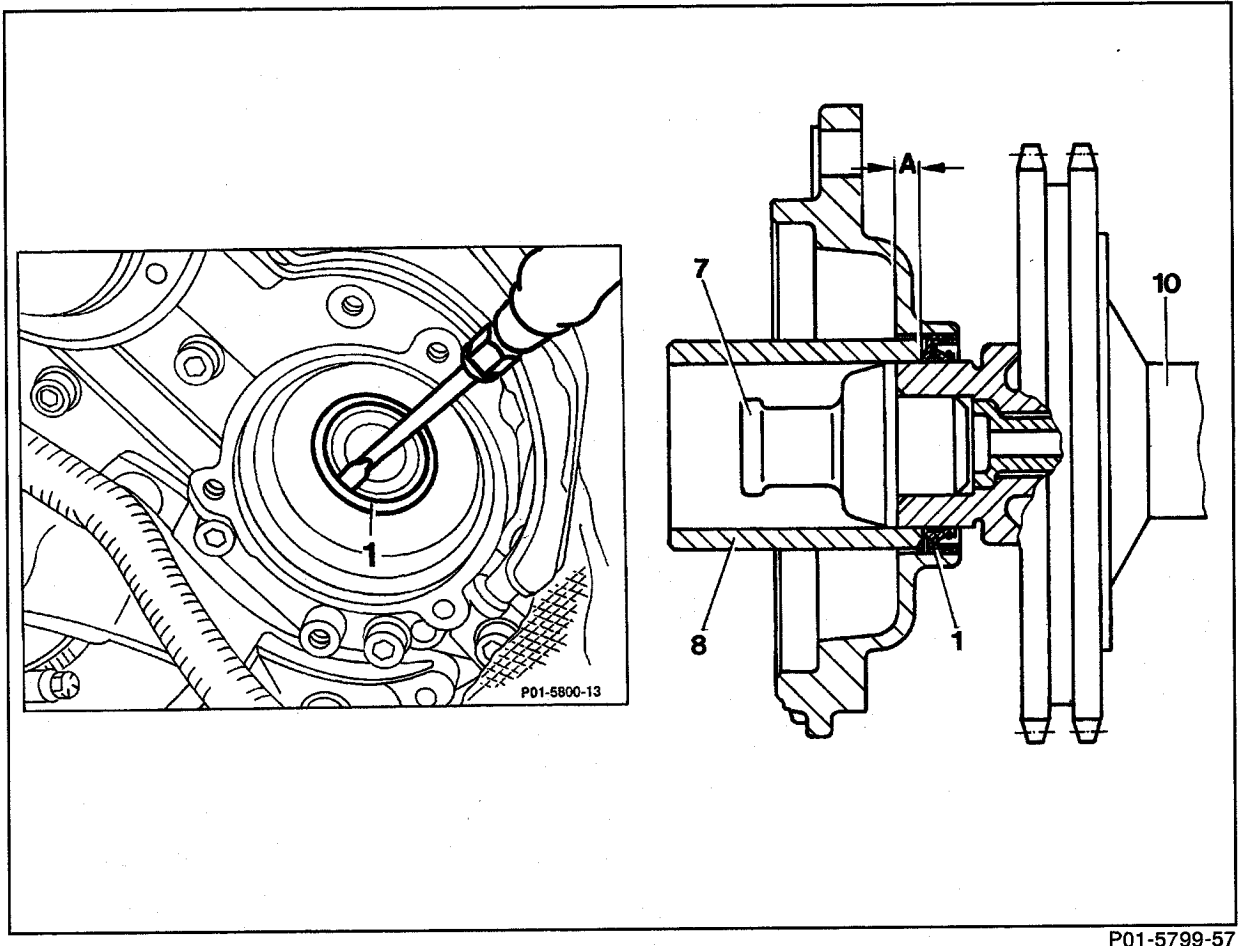

P01-5799-57

- Insertion sleeve (7) fit on to exhaust camshaft (10), special tool 119 589 00 14 00.
- Sealing lip of radial seal (1) coat with engine oil.



Do not use grease! Grease prevents the return delivery swirl on the sealing lip of the radial shaft seal (1) transporting back the engine oil.

- Radial shaft seal (1) fit onto insertion sleeve (7).

Radial shaft seal (1) press in with sleeve (8) (shop-made) to size "A=5 mm".

Note

The radial shaft seal (1) must be positioned vertically to the camshaft (10) in order to provide a proper seal.

Holder of shield caps of high tension distributors . remove, install.

Radial shaft seal (1) press out with a screwdriver.



Do not damage camshaft (10) and mounting hole for radial shaft seal (1).

Special tool

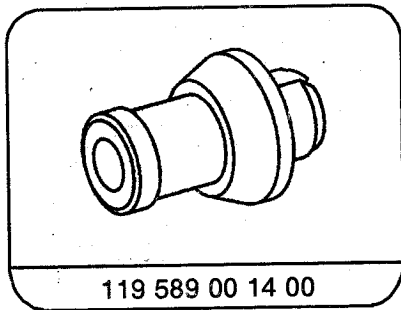

Shop-made tool

Sleeve (8) for pressing radial shaft seal into the front cover.

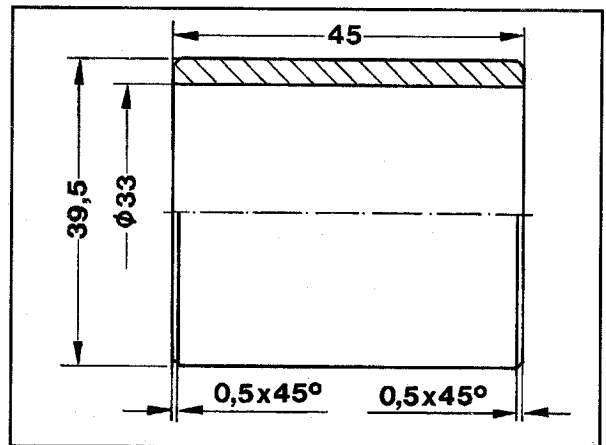

P01-5807-13

B. Engine 119.96/97 with front cover removed

Preceding work:
Front covers removed (01-2120).

Operation no. of operation texts and work units or standard texts
and flat rates:

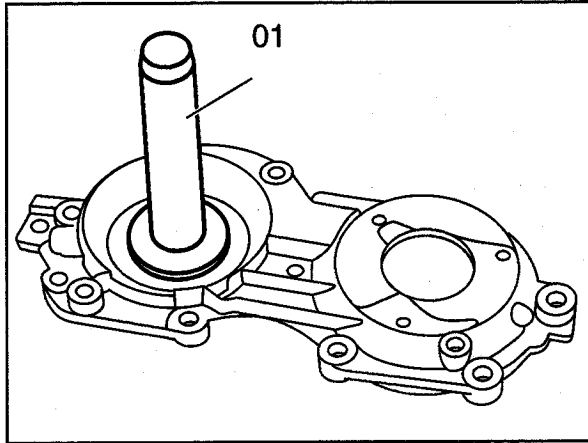

P01.10-0275-13

Radial shaft seal

press out with a screwdriver.

Radial shaft seal (1)

Do not damage mounting hole for the radial
shaft seal.

Radial shaft seal

fit onto drift (01) 119 589 01 15 00.

press in with drift (01).

Note

The insertion depth of 5 mm is obtained by
using the drift (01).

Special tool

