

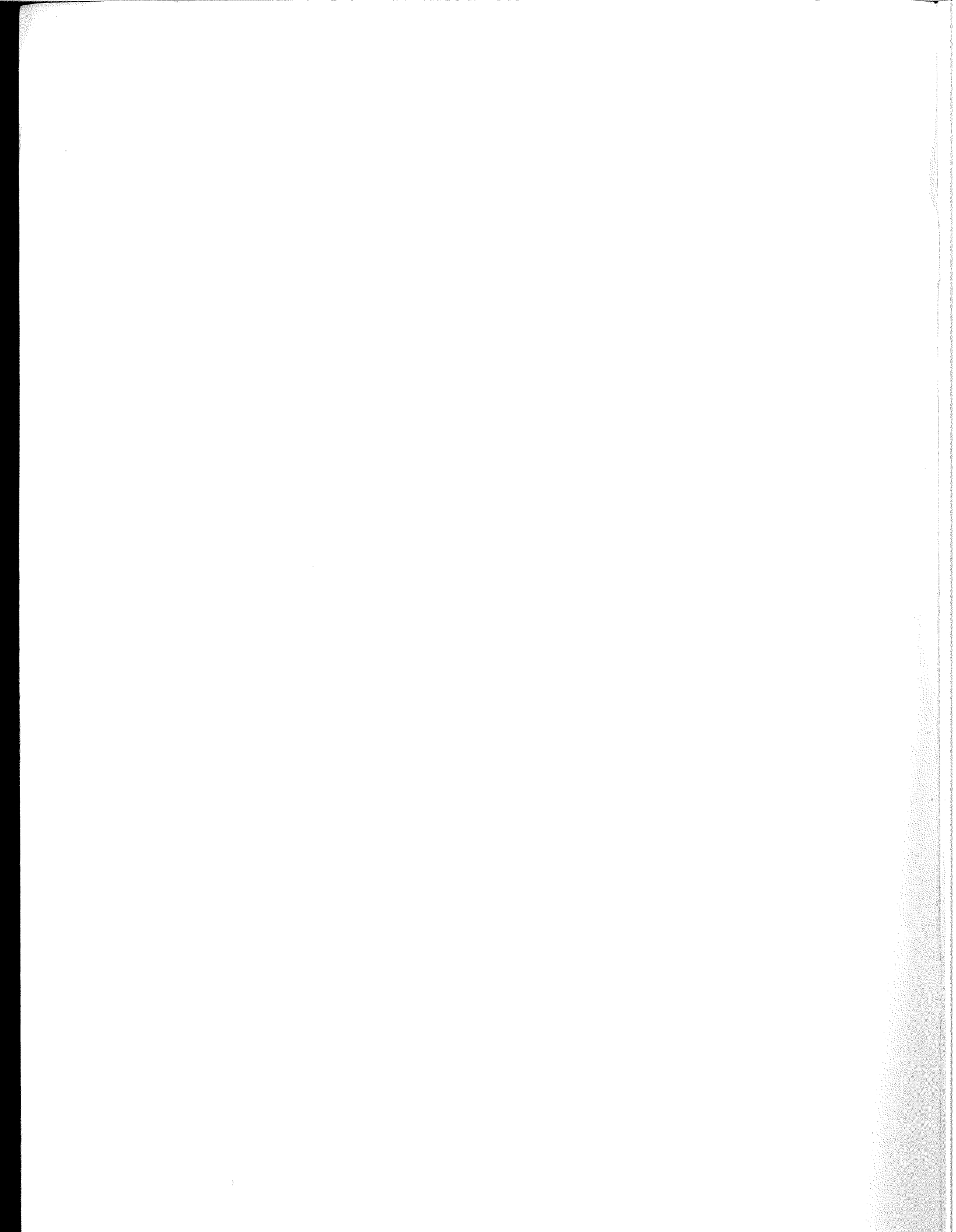

Mercedes-Benz

Service

Model Year 1992 (USA)
Models 124.034/036 (400 E/500 E)





Mercedes-Benz

Service

Model Year 1992 (USA)
Models 124.034/036 (400 E/500 E)

Introduction into service



Phil Smart, Inc.

600 E. Pike St.
Seattle, WA 98122



© Mercedes-Benz of North America, Inc., 1992

All rights reserved. Reproduction by any means, electronic or mechanical, including photocopying, recording, or by any information storage and retrieval system or translation in whole or part is not permitted without written authorization from the publisher.

Published by Mercedes-Benz of North America, Inc.
Printed in U.S.A.

With models 124.034/036 (400 E/500 E), model line 124 has been expanded by two characteristically sporty versions.

Product highlights as compared to model 124.051 (300 CE) are:

Models 124.034/036

- 8-cylinder engine with LH gasoline injection system.

Model 124.036

- Front track width increase of 37 mm, rear track width increase of 38 mm,
- Wide tires 225/55 ZR 16,
- Light alloy rims 8 J × 16 in new 8-hole design,
- Fenders flared in wheel arch areas,
- Front and rear bumper covers adapted to modified fenders,
- Fog lamps integrated into front bumper/spoiler cover.

Modifications respective to the engine, as compared to engines 119.970/971 in models 140.050/051, as well as modifications to the chassis and suspension, as compared to model 124.051, are detailed.

Until the latest repair instructions are available on microfiche, this Introduction Manual can be used by Mercedes-Benz service personnel to familiarize themselves with important technical details and to perform maintenance and repairs on these models.

All other repair instructions, adjustment values and maintenance jobs not listed here can be found in existing technical literature.

Mercedes-Benz Aktiengesellschaft
Vertrieb Personenwagen

February 1992

Table of contents

Vehicle and component identification . . .	1	20	Engine cooling system	
Vehicle views	5		Radiator	22
Technical highlights	6		Coolant pump	22
			Visco-fan clutch	22
			Fan shroud	22
			Heater return fitting	22
Engine		22	Engine suspension	
01 Cylinder crankcase, oil pan			Engine carrier	23
Cylinder crankcase	10		Rear engine mounts	23
Oil pan	10	30	Electronic accelerator	
05 Engine timing, valve train			Component locations	24
Camshafts	11			
07.4 LH gasoline injection system			Drivetrain	
General information	12		27 Automatic transmission	
Component locations	13		Starter lock-out switch	26
13 Belt drive			Control pressure bowden cable adjustment	26
Poly-V-belt	16		Installation survey, test and pressure values	27
14 Emission control system	17		Shift points with selector lever in position "D"	27
15 Electrical system – engine			Upshift delay (model 124.034) . . .	28
Electronic ignition with anti-knock control (EZL/AKR)	18	32	Suspension	
Alternator	20		General information	30
18 Engine lubrication system			Front damper strut	30
Oil pump	21		Rear shock absorbers, model 124.034 (without level control) . . .	31
Oil pressure sensor	21		Level control	32
Oil dipstick guide tube	21		Torsion bars	33
Oil filter	21		Cross reference - springs/rubber mounts	33
		33	Front axle	
			Steering knuckle arm and idler arm	34
			Wheel guidance, model 124.036 . .	34

Table of contents

<p>35 Rear axle Modified rear axle components . . . 35 Rear axle carrier 35 Gear set and rear axle shaft 36</p> <p>40 Wheels, chassis measurement Cross reference - wheels/tires/recommended tire brands 37 Light alloy wheel (8-hole design) . . . 37 Wheel bolts 38 Tire pressures 38 Snow chains 38 Chassis measurement (test and adjustment data) 39</p> <p>41 Propeller (drive) shaft 41</p> <p>42 Brakes Front wheel brake 42 Rear wheel brake 42 Brake pads, brake calipers, brake discs 43 Tandem master brake cylinder 43 Brake booster 43 Brake fluid 43 ABS 44 Acceleration slip control (ASR III) . . 44</p> <p>46 Steering Steering gear 46 Steering column jacket tube/ steering spindle 47 Steering wheel 47 Steering geometry, steering linkage 47</p> <p>47 Fuel system Fuel tank, model 124.036 48</p>	<p>54 Electrical system – equipment and instruments Battery 49 Module box (F23) 51 Control unit coordination 53 Removal and installation of control units 53 38-pole test connection for diagnosis (X11/4) 55 Instrument cluster 55 Two-tone fanfare horns 57</p> <hr/> <p>Body</p> <p>60–64 Body – general Body shell 57 Accident repair, use of straightening sets 57</p> <p>82 Electrical system – body CD changer 58 Exterior lighting 58 Windshield wiper system, model 124.036 60 Interior lighting 60</p> <p>88 Detachable body components Bumpers, model 124.036 61 Front fenders, model 124.036 61 Exterior panels, model 124.036 . . . 62 Trunk, model 124.036 62</p> <p>91 Seats, restraint systems Seats 63 Airbag 63</p> <p>Special tools 64</p>
--	--

Vehicle and component identification

Vehicle identification 1992 ^(USA) (partial)

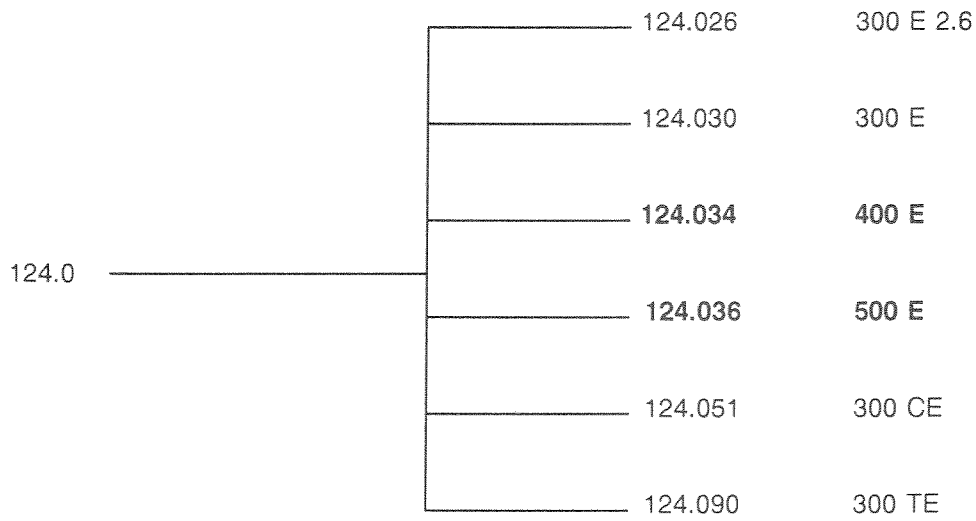

Component identification 1992 ^(USA) (partial)

Sales designation	Model	Engine	Manual transmission	Automatic transmission	Power steering
400 E	124.034	119.975	-	722.354	765.921
500 E	124.036	119.974	-	722.365	765.921

Vehicle identification

Vehicle identification number (VIN)

The following information is encoded into the VIN:
 Manufacturer, model, restraint system, model year, manufacturing plant and chassis end number.

Example, model 500 E: WDB E A 36 E X N B 123456

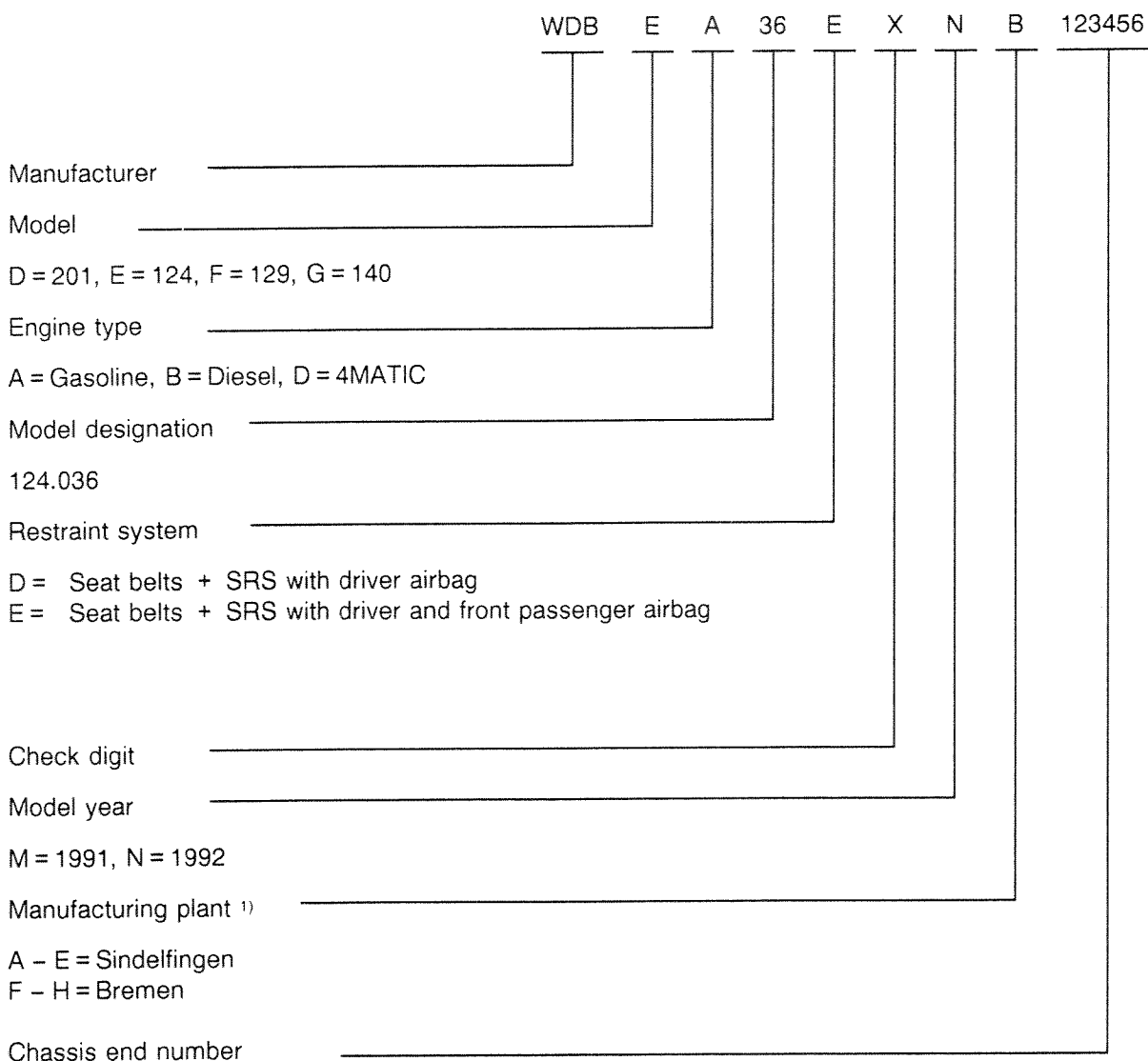

1) Manufacturing plant letter must be specified with the end number because simultaneous production at both plants may mean the same end number digits are assigned to two cars.

Engine family designations

The emission control system information plate attached to the radiator crossmember also shows the engine family designation. The engine family designation identifies model year, piston displacement, version, etc. (see example on next page).

Designations

Engine family	Version ¹⁾	Model	Sales designation
NMB 5.0 V 5 F A 10 ²⁾	A	124.034	400 E
NMB 5.0 V 5 F A 10	A	124.036	500 E

¹⁾ A = All 50 states (including California)

²⁾ For certification reasons, all 119.97 engines fall into the 5.0 liter engine family, even if the displacement equals only 4.2 liters (400 E).



Phil Smart, Inc.

600 E. Pike St.
Seattle, WA 98122



Technical highlights

Engine

Important engine data

Engine	Compression ratio	Displacement cm ³	Bore/stroke mm	Horsepower	Torque
119.974	10.0	4973	96.5/85.0	322 hp @ 5700 rpm 240 kW @ 5700 rpm	354 ft.lb. @ 3900 rpm 480 Nm @ 3900 rpm
119.975	10.0	4196	92/78.9	268 hp @ 5700 rpm 200 kW @ 5700 rpm	295 ft.lb. @ 3900 rpm 400 Nm @ 3900 rpm

- 01 **Cylinder crankcase, oil pan**
 - Detail modifications on cylinder crankcase.
 - Oil pan adapted to available space.
- 05 **Engine timing, valve train**
 - Valve timing and camshaft identification code changed.
- 07.4 **LH gasoline injection system**
 - Component locations.
- 13 **Belt drive**
 - Belt length modified.
- 14 **Emission control system**
 - Air injection and exhaust gas recirculation (EGR).
- 15 **Electrical system – engine**
 - Component locations.
 - Compact alternator 110 A with the following designation NC 14V 60/110 A.
- 18 **Engine lubrication system**
 - Location of oil pump suction strainer and oil level switch modified.
- 20 **Engine cooling system**
 - Two-piece fan shroud.
 - Coolant pump modified.
- 30 **Electronic accelerator**
 - Component locations.

Drivetrain

27 Automatic transmission

- Starter lock-out switch modified.
- Transmission 722.3 installed.
- Upshift delay for model 124.034.

32 Suspension

- Increased weight resulting in modifications to the following components:
 - Damper struts, shock absorbers/spring struts,
 - Front and rear springs,
 - Torsion bars.

- Model 124.034
Level control available as optional equipment.

- Model 124.036
Level control standard equipment.

Both damper and spring struts feature extension limiting springs.

Vehicle ride height lowered.

33 Front axle

- Model 124.036
Track widened 37 mm.

Rear control arm mounts connected by additional strut.

35 Rear axle

- Rear axle carrier reinforced.
- Rear axle center piece mount.
- 4-arm drive pinion flange with 110 mm bolt circle diameter.
- Rear axle shaft diameter modified with larger inner constant velocity joints.
- Reinforced camber link.

Technical highlights

- | | | |
|----|---|---|
| 35 | Rear axle (continued) | <ul style="list-style-type: none">● Model 124.036
Rear axle hub centering flange lengthened by approx. 2mm.
Track widened by 38 mm. |
| 40 | Wheels, chassis measurement | <ul style="list-style-type: none">● Forged light alloy wheel in new 8-hole design. |
| 42 | Brakes | <ul style="list-style-type: none">● Front wheel brake with 4-piston fixed caliper and ventilated brake disc.
● Rear wheel brake with 2-piston caliper and ventilated disc brake.
● Model 124.034
Acceleration slip control (ASR) available as an option.
● Model 124.036
Acceleration slip control (ASR) standard equipment. |
| 46 | Steering | <ul style="list-style-type: none">● Steering gear 765.921 (LSL 068). |
| 47 | Fuel system | <ul style="list-style-type: none">● Model 124.036
90 liter (23.8 gal.) fuel tank of which 11.5 liters (3.0 gal.) are reserve. |
| 54 | Electrical system – equipment and instruments | <ul style="list-style-type: none">● Maintenance-free battery (12 V 100 A) installed in trunk.
● Control units in engine/component compartment consolidated into module box.
● 38-pole test connection for diagnosis integrated into module box. |

Body

60, 61, 62, 63, 64 Body – general

- Following areas of the body shell modified:
 - Front end,
 - Front and rear wheelhousings,
 - Firewall,
 - Tunnel,
 - Main floor,
 - Rear floor,
 - Various supports, reinforcements and consoles.
- Straightening sets from Celette and Car-Bench.

82 Electrical system – body

- CD changer available as an option.
- Model 124.036
Range of extended-reach wiper increased by 4 mm.

Headlamp units with auxiliary high beams in place of fog lamps.

Ellipsoid fog lamps integrated in front bumper cover/spoiler.

88 Detachable body components

- Model 124.036
Front bumper cover reshaped to reduce front axle lift.

Front and rear bumper covers as well as side protection panels adapted to modified front and rear fender contours.

91 Seats

- Model 124.036
Sport 4-place leather seating.

Cylinder crankcase, oil pan

Engines 119.974/975 are identical in design to engines 119.970/971 (models 140.051/042), with the exception of the following details.

Cylinder crankcase

Mounting flange for left and right engine mount arms each have two additional threaded bolt holes.

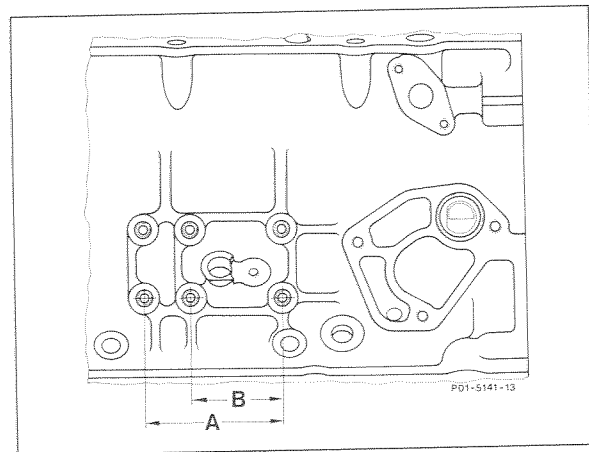

- A Models 124 and 129
- B Model 140

Oil pan

Upper and lower oil pan halves modified to accommodate front crossmember. Upper oil pan half made of cast aluminum, lower half made of steel.

The shape of the oil pan gasket and baffles has been changed.

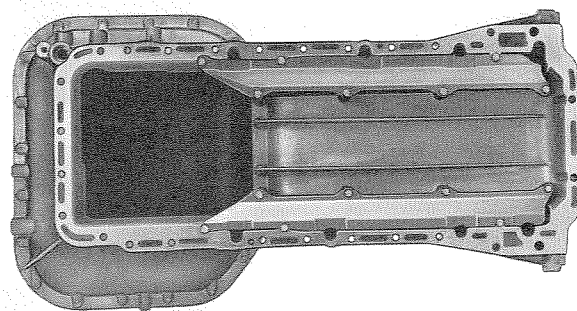

P01-0289-13

Engine timing, valve train

Camshafts

Modified camshaft identification code on left exhaust camshaft (engine 119.974 only).

Valve timing in degrees of crankshaft angle at 2 mm valve lift and new timing chain

Engine	Camshaft identification code ²⁾				Intake valve ³⁾		Exhaust valve	
	Intake camshaft		Exhaust camshaft		opens after	closes after	opens before	closes before
	right	left	right	left	TDC	BDC	BDC	TDC
119.974	74 75 ⁴⁾	72 73 ⁴⁾	78 79 ⁴⁾	60 77 ⁴⁾	30.0°	40.0°	13.0°	13.0°
119.975	82 83 ⁴⁾	80 81 ⁴⁾	86 87 ⁴⁾	84 85 ⁴⁾	30.0°	35.0°	8.0°	13.0°

1) Allowable tolerance: $\pm 2.0^\circ$ Perform test only on ascending cam (in direction of engine rotation).

2) Camshaft identification number inscribed on front of 3rd camshaft bearing journal or stamped with paint on back of camshaft flange.

3) Camshaft adjuster retarded.

4) Repair size camshaft with 0.5mm larger bearing diameter.



Phil Smart, Inc.

600 E. Pike St
Seattle, WA 98102

LH gasoline injection system

General information

In order to obtain a more accurate and more fuel efficient fuel delivery at all engine operating conditions, an electronic gasoline injection system with air mass measurement by means of a heated wire is installed on these engines.

The abbreviation LH means:

L = *Luftmassenmessung* = air mass
measurement

H = *Hitzdraht* = hot-wire

The basic system of the LH gasoline injection system is a non-engine driven, electronically controlled gasoline injection system. This system makes a direct measurement of the inducted air mass by means of a hot-wire air mass sensor.

Operation of the LH gasoline injection system is described in the Introduction Manual for model 140.

The respective component locations for models 124.034/036 are illustrated on the following pages.

CHECK ENGINE warning lamp (A1e26)

California version model 124.034 vehicles and all model 124.036 vehicles are equipped with the CHECK ENGINE warning lamp which is activated by the diagnostic module (N59). Federal version model 124.034 vehicles are not equipped with a CHECK ENGINE warning lamp to indicate a malfunction in the O₂-sensor signal circuit.

Diagnostic module (N59)

All model 124.036 (500 E) vehicles are California version vehicles and as such, are equipped with a diagnostic module (N59). However, only the California version of model 124.034 (400 E) is equipped with the diagnostic module.

For a functional description of the diagnostic module, see Introduction Manual for model 140, engines 119.970/971.

Component locations

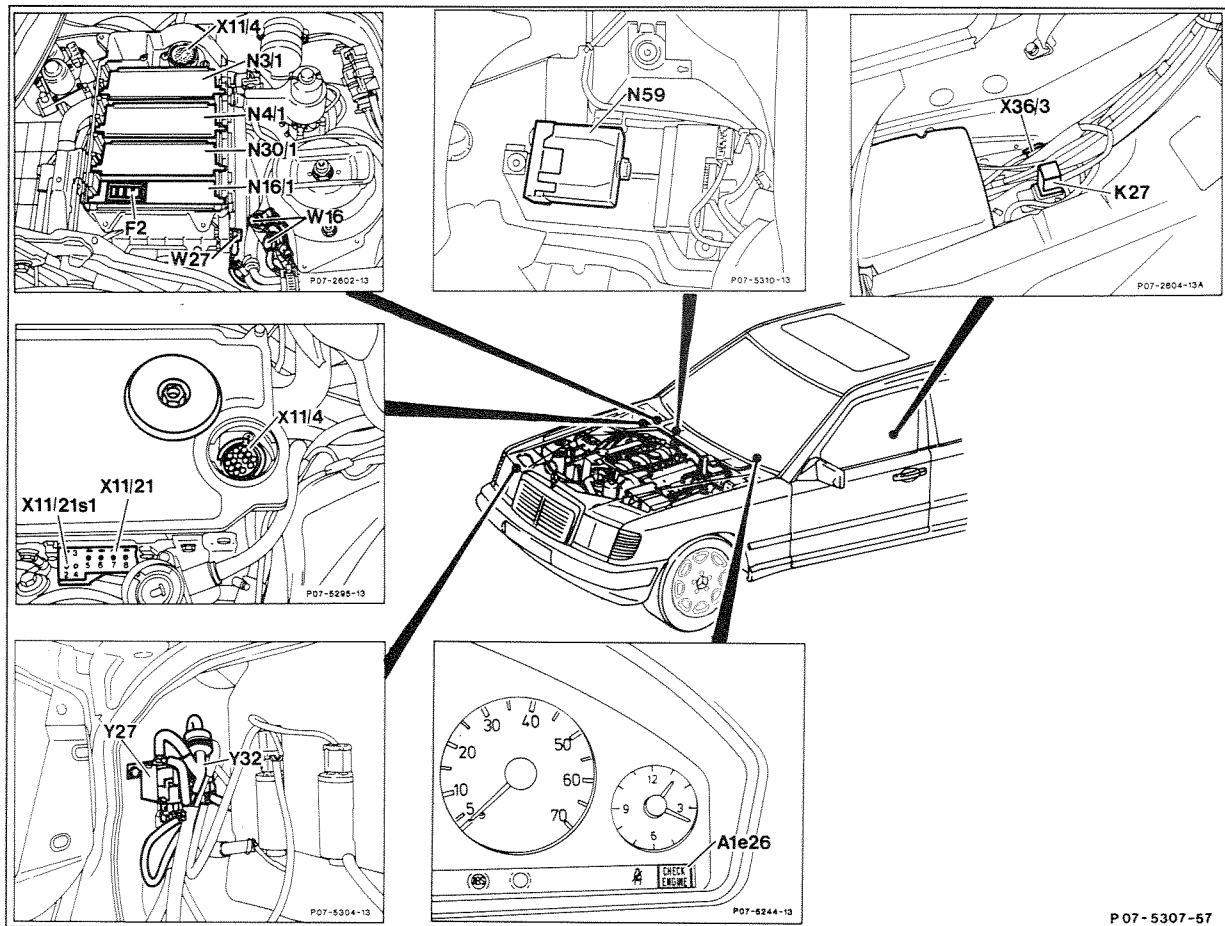

A1e26 "CHECK ENGINE" warning lamp
 K27 Fuel pumps relay
 N3/1 LH control unit
 N4/1 Electronic accelerator control unit
 N16/1 Base module
 N59 Diagnostic module (California version model 124.034, all model 124.036)

X11/4 Test connection for diagnosis (impulse readout, 38-pole)
 X11/21 Test connection for diagnostic module
 X11/21s1 Pushbutton with LED
 Y3/3 Upshift delay switchover valve
 Y27 EGR switchover valve
 Y32 Air injection pump switchover valve

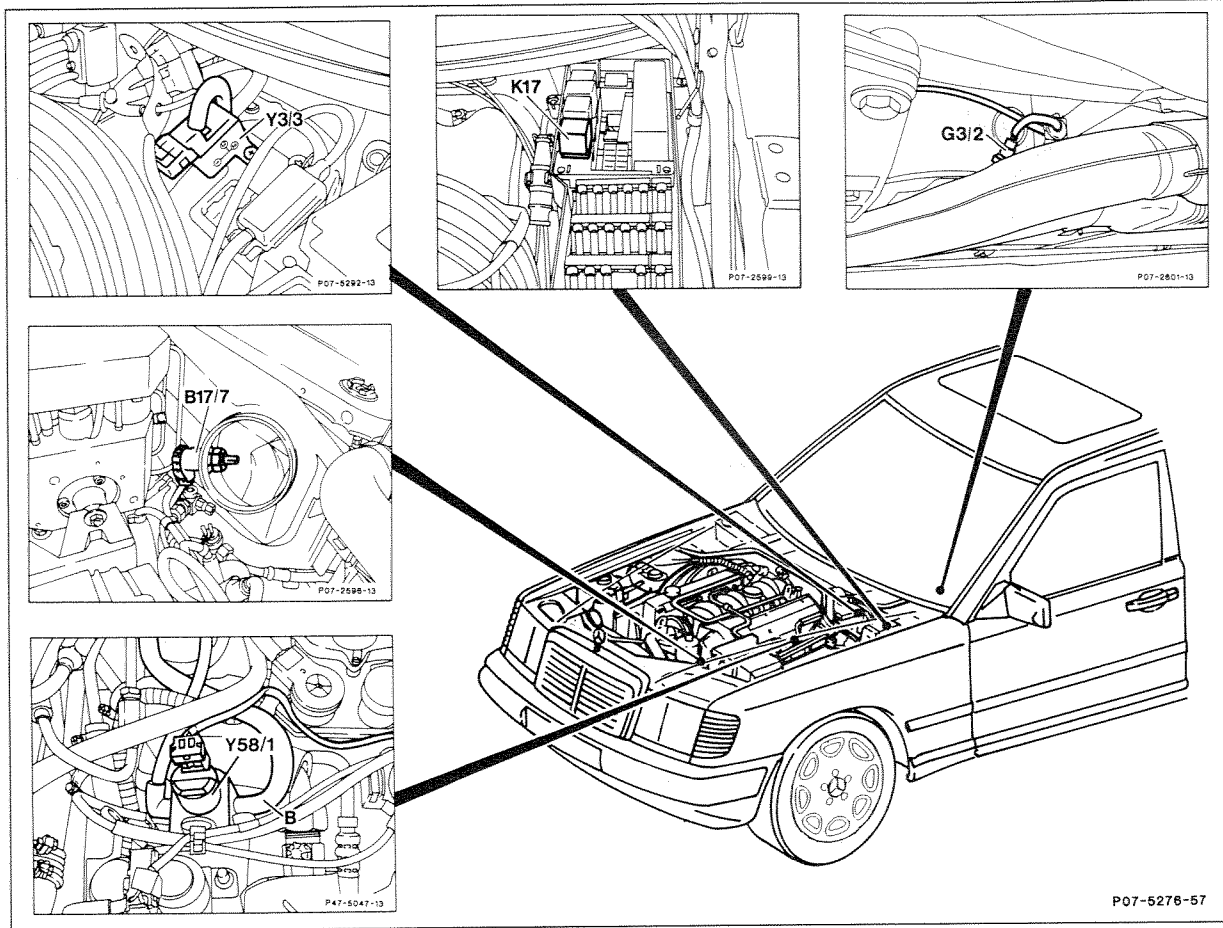

B17/7 Intake air temperature sensor
 G3/2 Heated O₂-sensor
 K17 Air injection relay

Y3/3 Upshift delay switchover valve
 Y58/1 Purge switchover valve

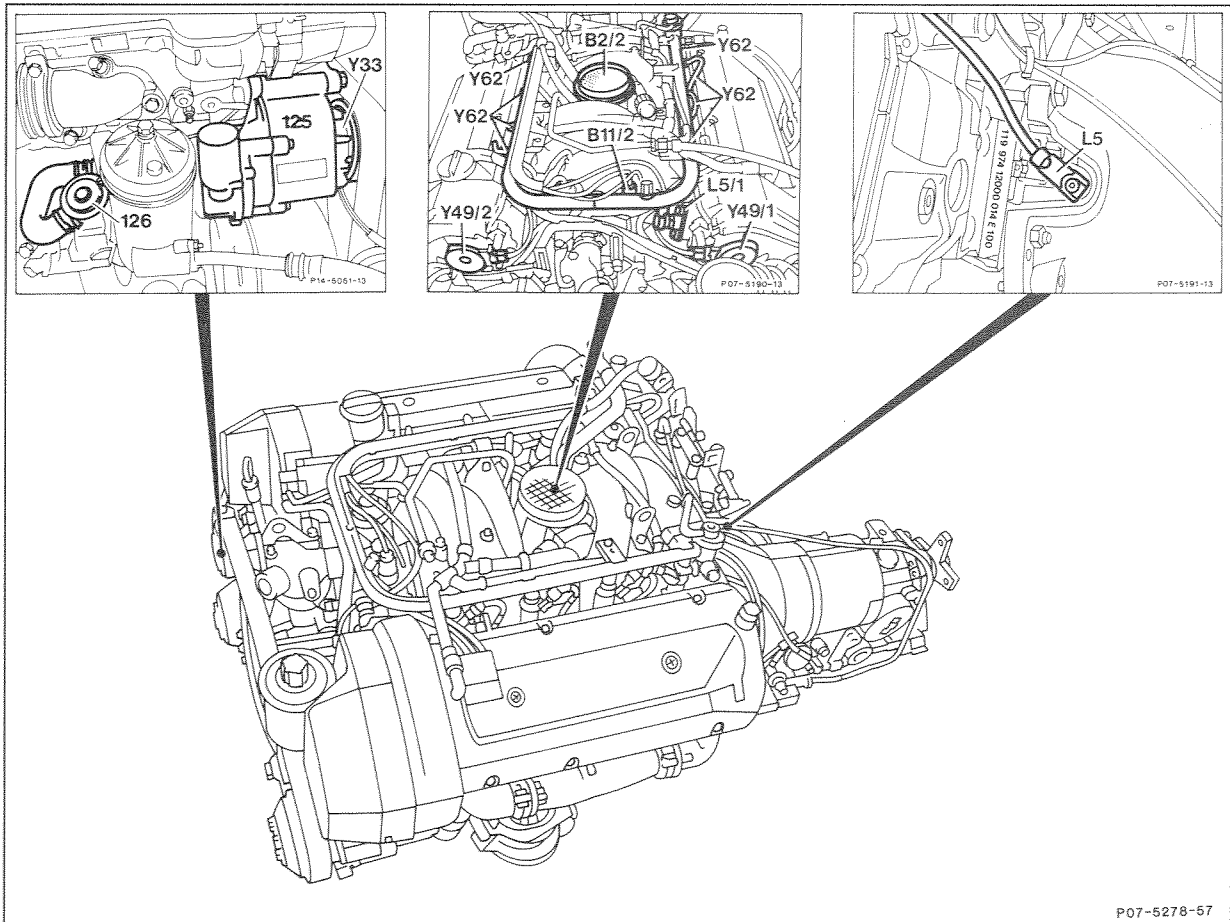

B2/2 Air mass sensor with hot-wire
 B11/2 Coolant temperature sensor (4-pole)
 L5 Crankshaft position sensor
 L5/1 Camshaft position sensor

Y33 Electromagnetic air injection pump clutch
 Y49/1 Solenoid, left adjustable camshaft timing
 Y49/2 Solenoid, right adjustable camshaft timing
 Y62 Fuel injection valves

Belt drive**Poly-V-belt****Belt routing diagram**

Belt length 2465 mm

- 1 Tensioning pulley
- 2 Crankshaft
- 3 A/C compressor
- 5 Fan
- 7 Air injection pump
- 8 Alternator
- 10 Power steering pump
- 11 Coolant pump

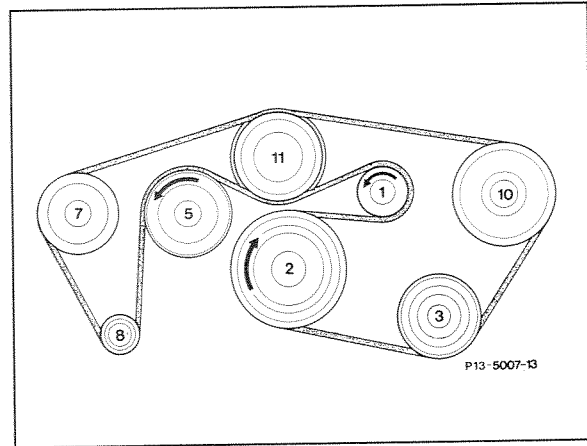

Emission control system

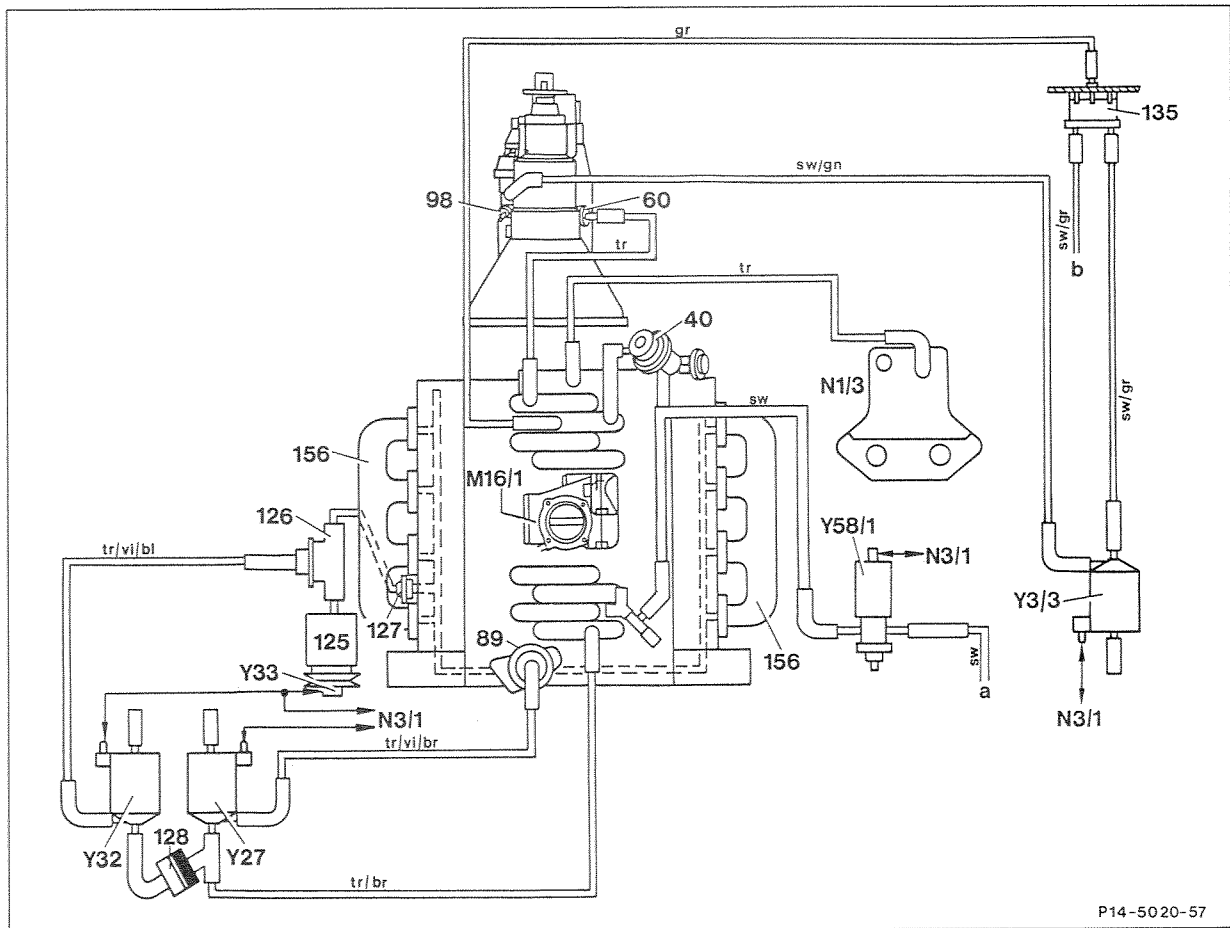

Function diagram, air injection and exhaust gas recirculation as well as vacuum supply

40	Diaphragm pressure regulator	Y3/3	Upshift delay switchover valve
60	Vacuum element	Y27	EGR switchover valve
74	Fuel cooler	Y32	Air injection pump switchover valve
89	EGR valve	Y33	Electromagnetic air injection pump clutch
98	Vacuum element, upshift delay	Y58/1	Purge switchover valve
125	Air injection pump	a	Active charcoal canister
126	Air injection shut-off valve	b	Consumers
127	Check valve (air injection)		
128	Check valve (vacuum)		
135	Check valve (vacuum supply)		
156	Exhaust manifold	rt	red
M16/1	Electronic accelerator actuator	gr	grey
M16/2	Cruise control/idle speed control actuator	sw	black
N1/3	EZL/AKR ignition control unit	tr	transparent
N3/1	LH control unit	vi	violet
		br	brown
		bl	blue

Electrical system – engine

Electronic ignition system with anti-knock control (EZL/AKR)

With the exception of individual component locations, the EZL/AKR ignition system is identical to the system installed in engines 119.970/971 in model 140.

The functional description of the electronic ignition system is covered in the SMS, Combustion, Engine 119, LH-injection system.

Component locations

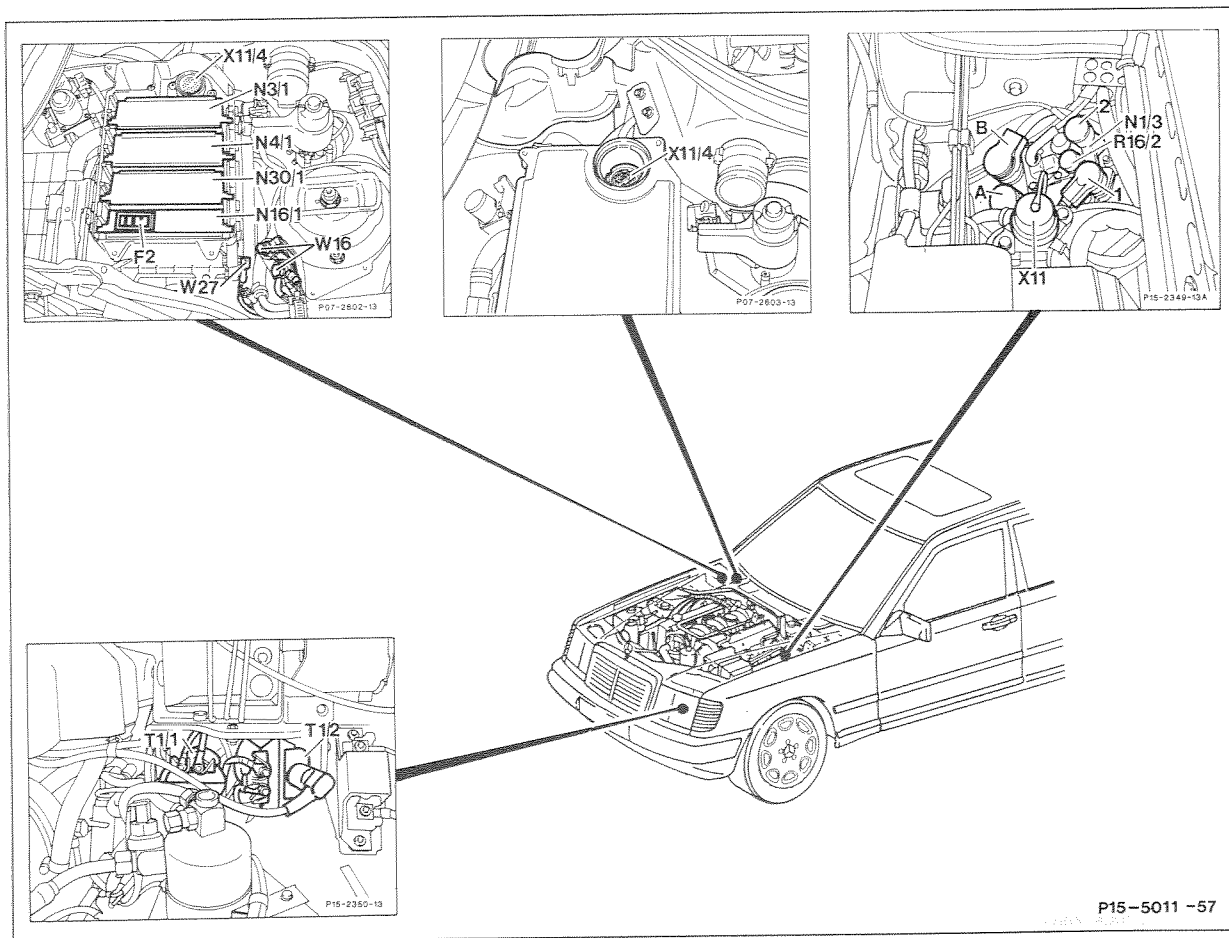

N1/3 EZL/AKR ignition control unit
 N3/1 LH control unit
 N4/1 Electronic accelerator control unit
 N16/1 Base module
 N30/1 ABS/ASR control unit
 R16/2 Reference resistor (EZL/AKR)

T1/1 Ignition coil 1 (right cylinder bank)
 T1/2 Ignition coil 2 (left cylinder bank)
 X11 Diagnostic socket (9-pole)
 X11/4 Test connection for diagnosis (impulse readout, 38-pole)
 A, B 8-pole connection
 1 Connector, knock sensors (A16)
 2 Connector, crankshaft position sensor (L5)

P15-5011 -57

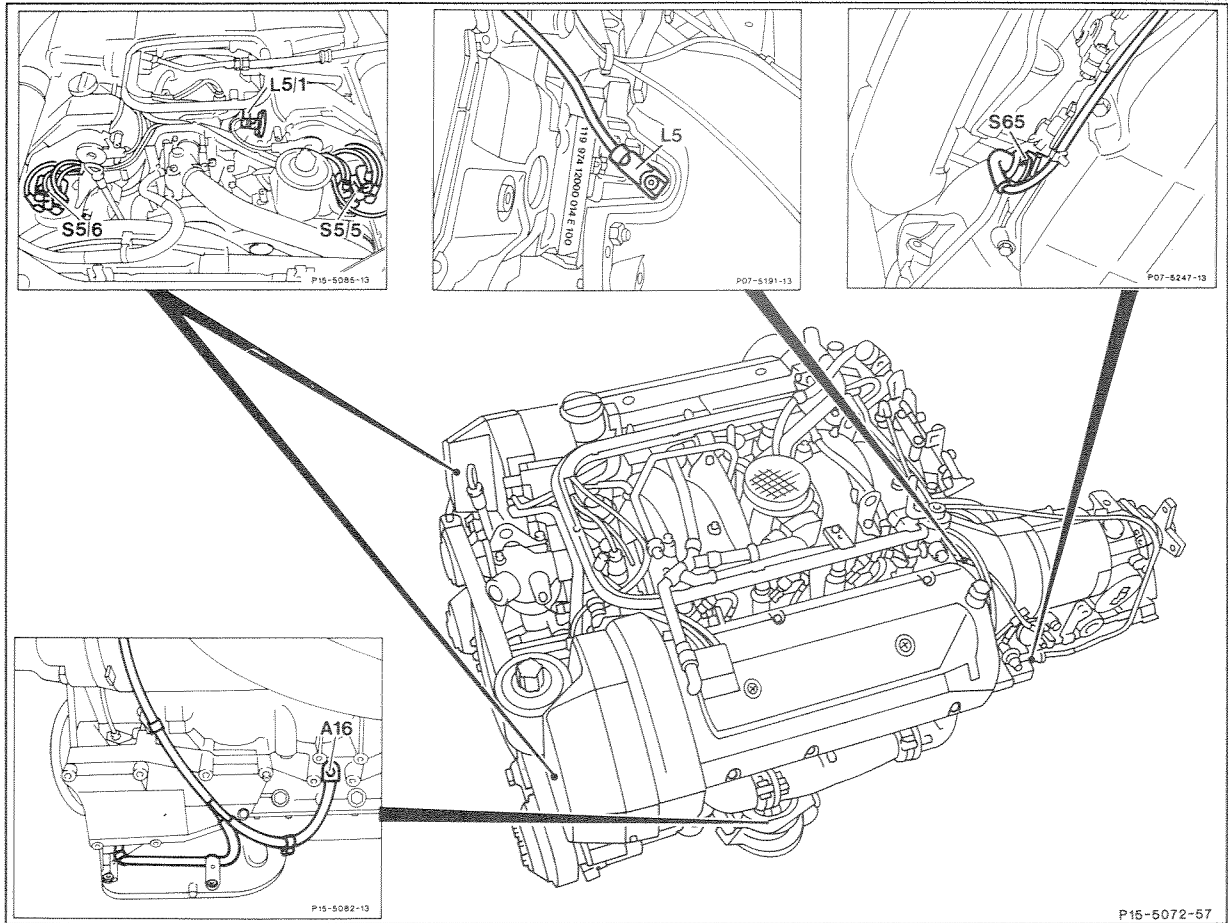

- | | | | |
|------|----------------------------|------|---|
| A16 | Knock sensors | S5/5 | Left high-voltage distributor |
| L5 | Crankshaft position sensor | S5/6 | Right high-voltage distributor |
| L5/1 | Camshaft position sensor | S65 | Transmission overload protection switch |

Alternator

Compact 110 A alternator with the following designation:
NC 14V 60/110 A.

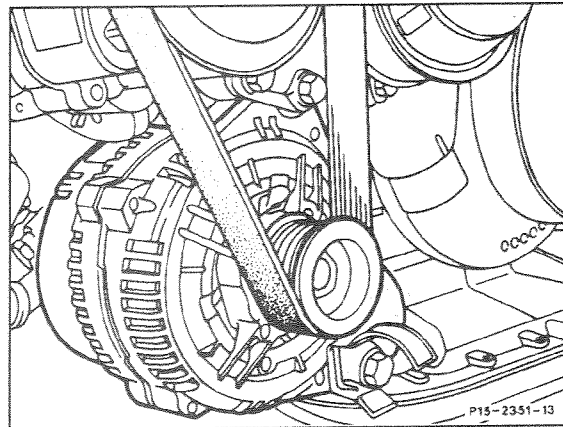

Charging current

Engine rpm	Alternator rpm	Charging current
2180	6300	110 A

Engine lubrication system

Oil pump

Location of oil pump suction strainer and oil level switch changed.

Oil pressure sensor

The 1-pole oil pressure sensor is mounted on a steel oil line. The oil pressure gauge is identical to model 124.

Oil dipstick guide tube

The shape of the guide tube was changed due to the modified oil pan.

Oil filter

The oil cooler line connections are sealed off with a plug and an O-ring since an engine oil cooler is not installed. The thermostat (oil temperature control) was deleted.

Engine cooling system

Radiator

Transverse mounted radiator with 29.8 dm² cooling surface with integrated transmission oil cooler on right side of radiator.

Two electric auxiliary cooling fans are mounted in front of the A/C condensor.

The radiator mounting console is attached with screws.

Coolant pump

Coolant pump inlet without air bleed fitting.

Visco-fan clutch

The fan engagement temperature was lowered from $96 \pm 4^\circ\text{C}$ to 82°C . The visco-fan clutch housing was modified, thereby moving the fan 8 mm closer to the engine. The cover was adapted to the modified housing and has an open center in the front.

Bimetallic spring identification number:
119 200 01 22.

Fan shroud

The two-piece fan shroud with lateral air flaps was adapted to available space. The fan shroud is divided transversely in the middle and can be separated by removing the fan shroud ring.

Heater return fitting

The heater return fitting was adapted to available space on the right rear of the crankcase.

Engine suspension

Engine carrier

Adapted to modified installation conditions.

Rear engine mounts

Round rubber mounts mounted on die-cast aluminum crossmember.

Electronic accelerator

Component locations

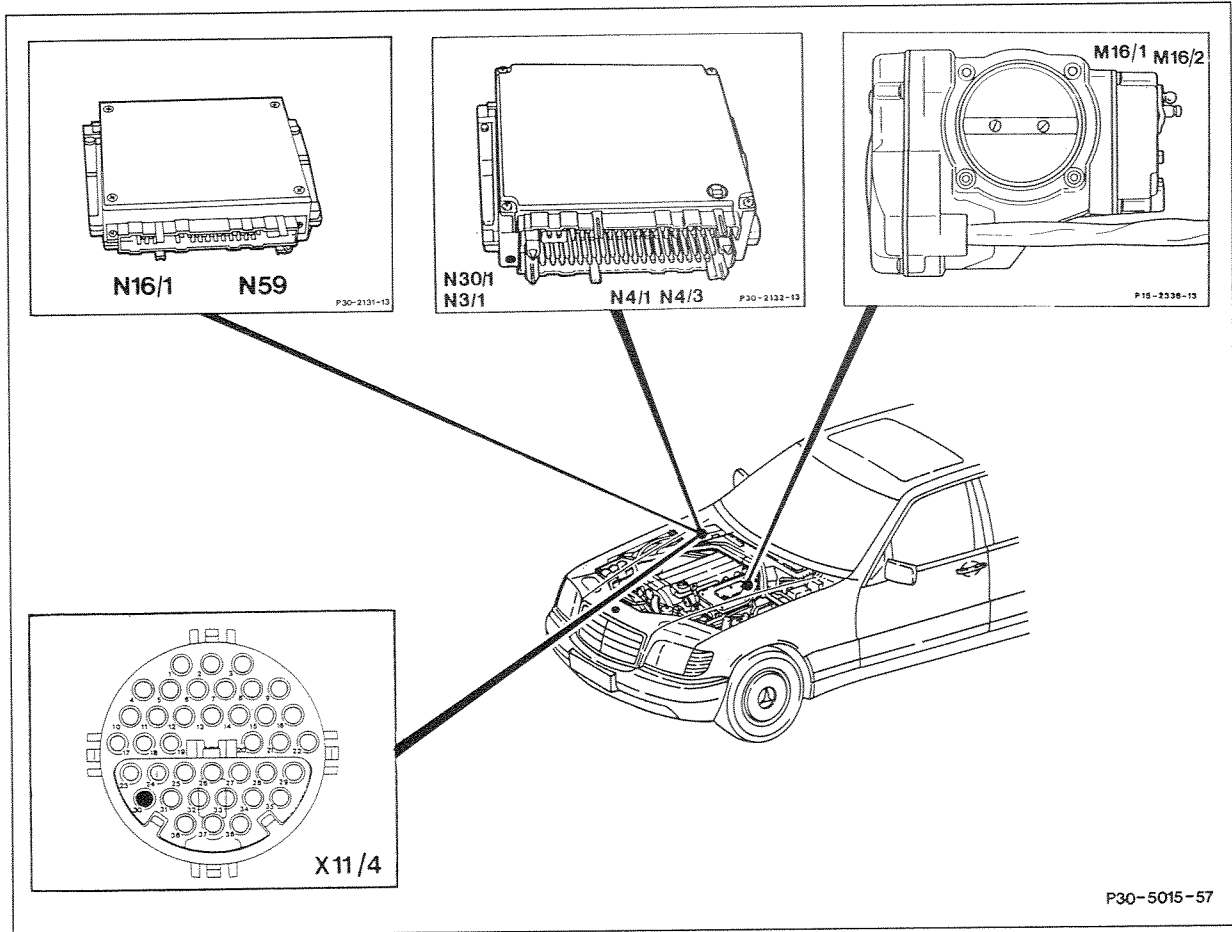

M16/1 Electronic accelerator actuator
 N3/1 LH control unit
 N4/1 Electronic accelerator control unit

N16/1 Base module
 N30/1 ABS/ASR control unit
 N59 Diagnostic module (California version model 124.034 and all model 124.036)
 V2 Diode matrix, engine rpm increase
 X11/4 Test connection for diagnosis (impulse readout, 38-pole)

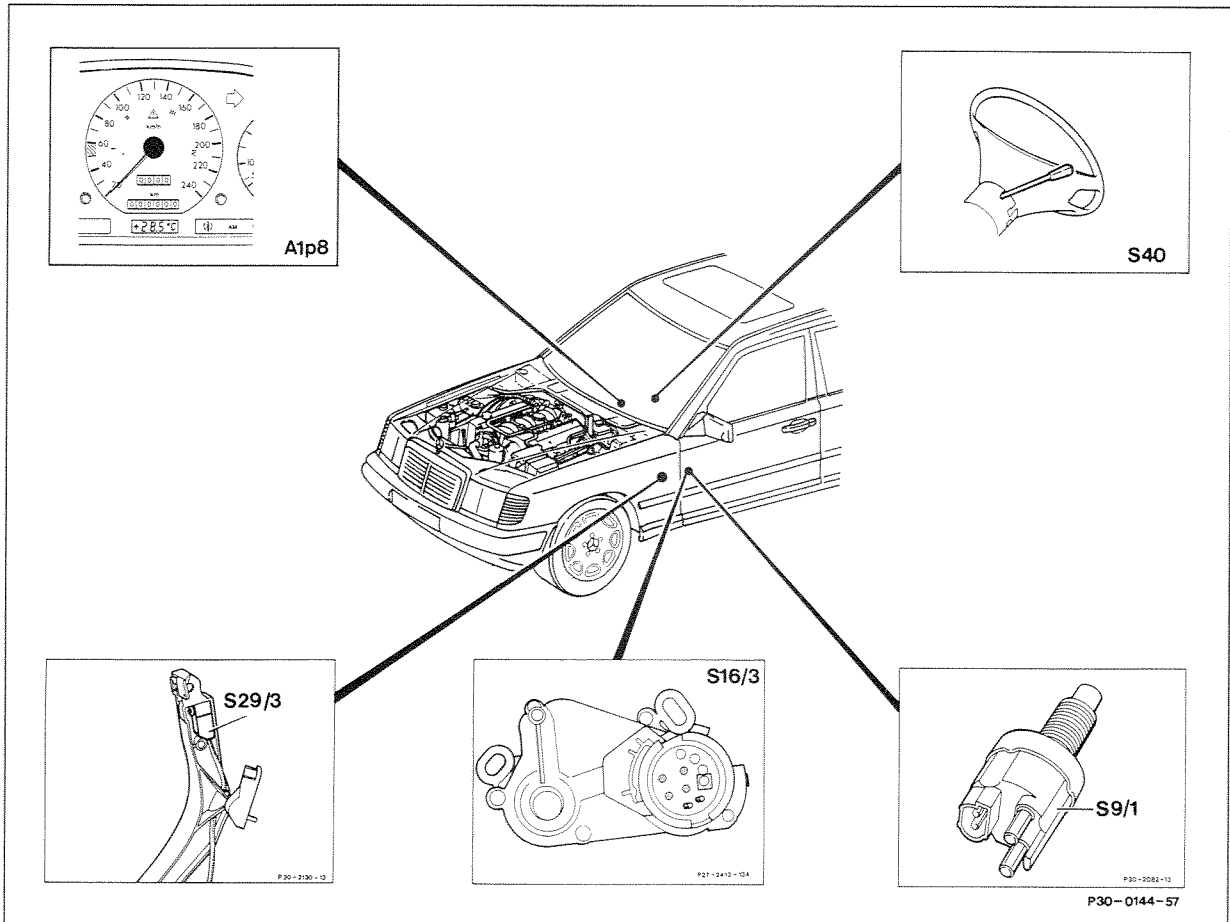

- A1p8 Electronic speedometer
- S9/1 Stop lamp switch
- S16/3 Starter lock-out/backup lamp switch, selector lever position recognition
- S29/3 Idle speed contact switch

- S40 Cruise control switch
 - V Decelerate/set
 - B Accelerate/set
 - SP Resume
 - A Off

Automatic transmission

The familiar transmission type 722.3 is installed.

Starter lock-out switch

The starter lock-out switch (S16/3) is new. It is equipped with two additional connector pins (arrow) for transmission selector lever position recognition during cruise control operation. For test procedures, see Diagnostic Manual, Engines, volume 2, section 6.

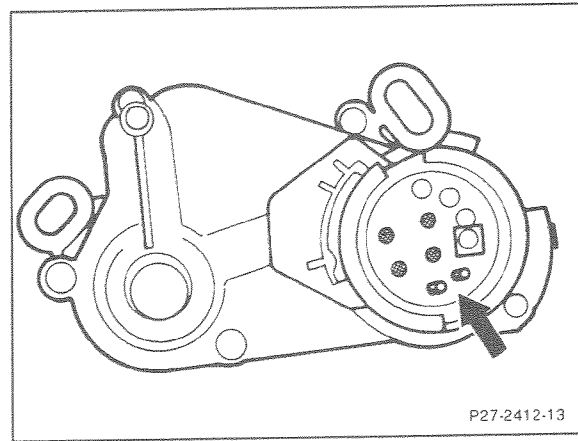

Control pressure bowden cable adjustment



Throttle control linkage must be properly adjusted.

1. Remove air filter.
2. Loosen hex nuts (6) on connecting rod (8).
3. Turn connecting rod (8) until the tips of the indicators line up with one another.
4. Tighten hex. nuts (6).

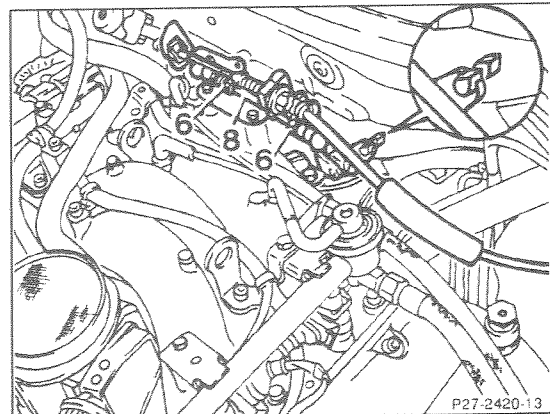

Installation survey, test and pressure values

Model		124.034	124.036
Transmission type		722.354	722.365
Transmission	part no.	124 270 03 02	140 270 22 02
Vacuum modulator	color	natural	black
Modulating pressure	bar	3.8	4.0
Torque converter dia.	mm	290	290

Shift points with selector lever in position "D"

Model	Accel. pedal position	Shifts at approx. km/h (mph)					
		1→2	2→3	3→4	4→3	3→2	2→1
124.034	Full throttle	60 (38)	125 (78)	197 (123)	122 (76)	45 (28)	25 (16)
	Kickdown	80 (50)	136 (85)	208 (130)	186 (116)	112 (70)	48 (30)
124.036	Full throttle	46 (29)	104 (65)	163 (102)	114 (71)	40 (25)	24 (15)
	Kickdown	67 (42)	112 (70)	169 (106)	153 (96)	92 (58)	38 (24)

Upshift delay

Model 124.034

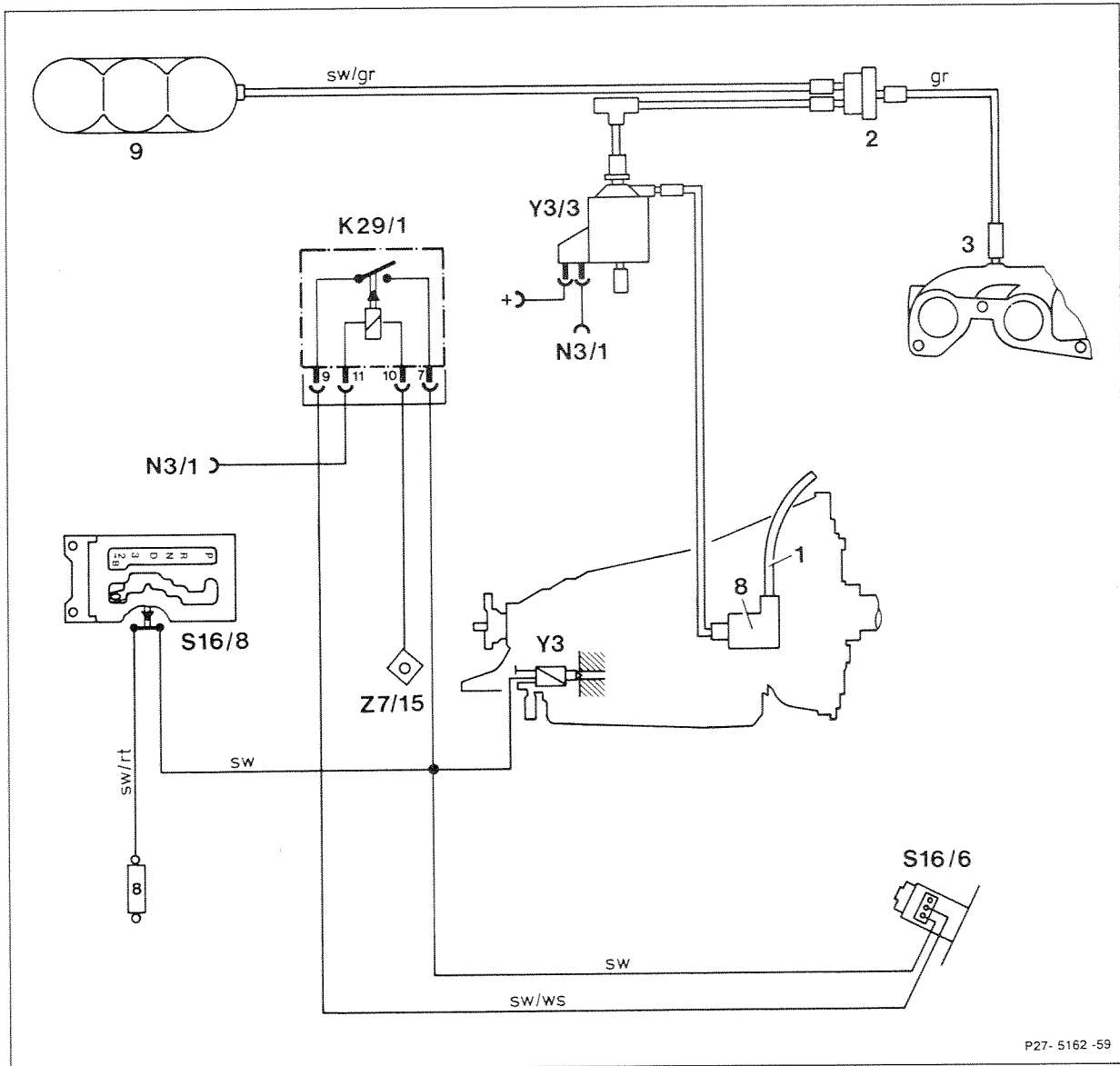

P27- 5162 -59

- 1 Control pressure cable
- 2 Check valve
- 3 Intake manifold
- 8 Upshift delay vacuum element
- 9 Vacuum reservoir

- K29/1 First gear start relay
- N3/1 LH control unit
- S16/6 Kickdown switch
- S16/8 "B" engagement switch
- Y3 Kickdown valve
- Y3/3 Upshift delay switchover valve
- Z7/15 Connector sleeve, terminal 87 (LH)

- sw black
- ws white
- gr grey

Upshift delay for rapid heating of catalyst Model 124.034

In order to rapidly heat the catalyst after starting the engine, the transmission is equipped with an upshift delay to raise the shift point for the 2 – 3 upshift. Operation of the 2 – 3 upshift delay is described in Group 27 of the Model Year 1992 Introduction Manual for model 140.

In addition, the transmission is equipped with a 1 – 2 upshift delay which is active at coolant temperatures below 40 °C. The 1 – 2 upshift delay occurs:

- After exceeding a vehicle speed of 8 km/h (5 mph) for 8 – 13 seconds up to maximum of 38 km/h (24 mph).

The 1 – 2 upshift delay is controlled by the LH control unit and the first gear start relay (K29/1) which is located in the fuse and relay box, position "E".

Note:

A malfunction of the 1 – 2 upshift delay is stored as impulse readout "29" in the LH control unit's malfunction memory.



Phil Smart, Inc.

600 E. Pike St.
Seattle, WA 98122

Suspension

General information

Model 124.036

The vehicle ride height was lowered by 23 mm. Due to the increased vehicle weight, the following suspension components were modified on both models:

- Front damper struts
- Rear axle spring struts
- Front and rear springs
- Torsion bars

By using somewhat stiffer spring and damper strut settings, driving stability could be further improved with respect to the vehicles' high performance capability and increased weight. Rear axle level control is standard on model 124.036 and is available as a special order option on model 124.034.

Front damper strut

Model 124.034

The tightening torque for the damper strut/steering knuckle assembly was increased to **200 Nm** through the use of a larger M14X1.5 pinch-bolt (11k) and self-locking hex. nut (11u). As a result, the steering knuckle upper mounting hole diameter was increased to 14 mm and the damper strut mounting hole diameter was increased to 15 mm. The tightening torque of 110 Nm for both lower microencapsulated hex. bolts (11i) remains unchanged. This reinforced damper strut mount will also be phased into production for model 124.036.

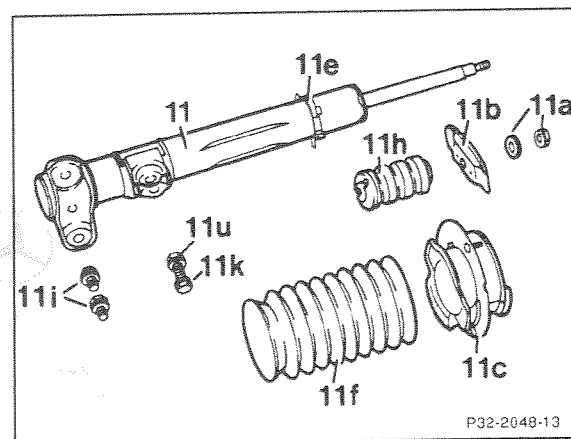

Model 124.036

The damper strut is equipped with an extension limiting spring (11m), giving additional vehicle support during cornering.

Models 124.034/036

A harder suspension stop buffer (11h) is used between the damper strut and damper strut mount, the damper struts are color coded (see table).

11	Damper strut
11g	Piston rod
11h	Buffer
11m	Extension limiting spring

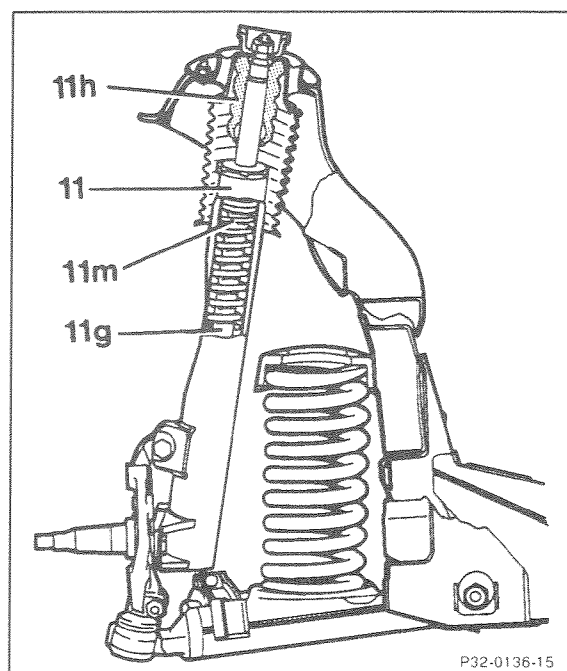
**Damper strut color code**

Model	124.034	124.036
Number	2	9
Color	white	yellow

Buffer

Model	124.034	124.036
Length	83 mm	70 mm
Color	red	natural

Rear shock absorbers**Model 124.034 (without level control)**

Color code:

Number: 2

Color: white

Modified buffer (75i)

Length: 75 mm

Color: natural

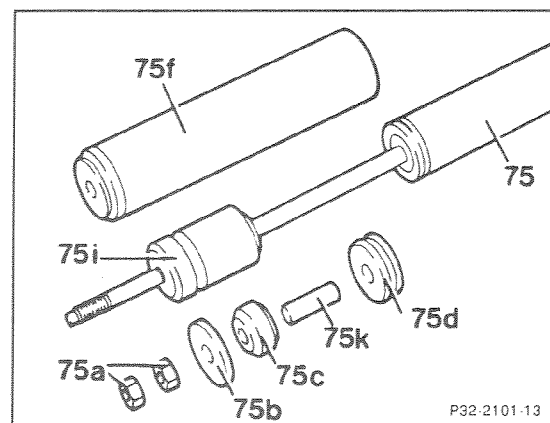

Level control

The oil reservoir (2) is located in the front right-hand side of the engine compartment.

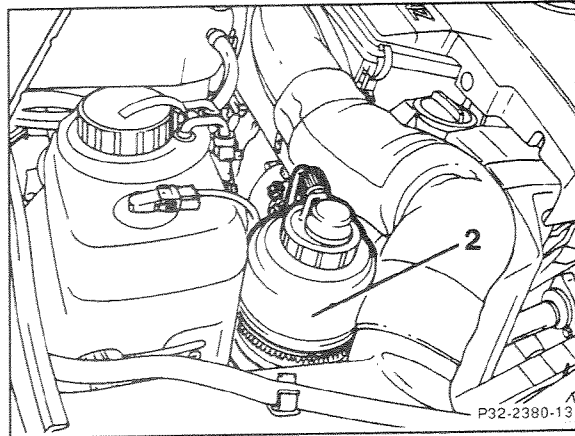

The connecting rod (7) is attached to the outer bore of the lever (3a) on the leveling valve (3).

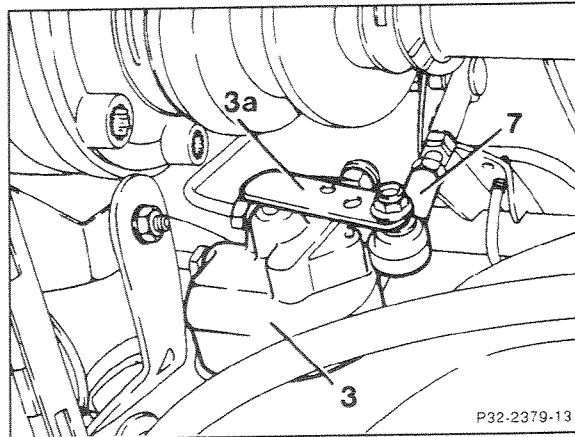

Rear axle spring strut

The rear axle spring strut, like the front axle damper strut, has an extension limiting spring (model 124.036 only).

The spring strut is color coded (see table).

Spring strut color coding

Model	124.034	124.036
Number	5	9
Color	white	white

Torsion bars

The diameters of the front and rear torsion bars were increased (see table below).

Torsion bar diameters

Model	Front axle	Rear axle
124.034	26.5 mm	16 mm
124.036	28 mm	18 mm

Cross reference - springs/rubber mounts

For information regarding spring/rubber mount combinations, see respective parts microfiche, group 32.

Front axle

Steering knuckle arm and idler arm

The steering knuckle and idler arms were adapted to the lower installation position of the steering gear i.e. modified steering geometry.

Wheel guidance

Model 124.036

Spindles, hubs, wheel bearings, damper struts as well as control arms were adapted from model 129. The front track was widened by 37 mm to 1534 mm total width.

The rear control arm mounts are connected by an additional strut (arrow) for increased vehicle stability during braking.

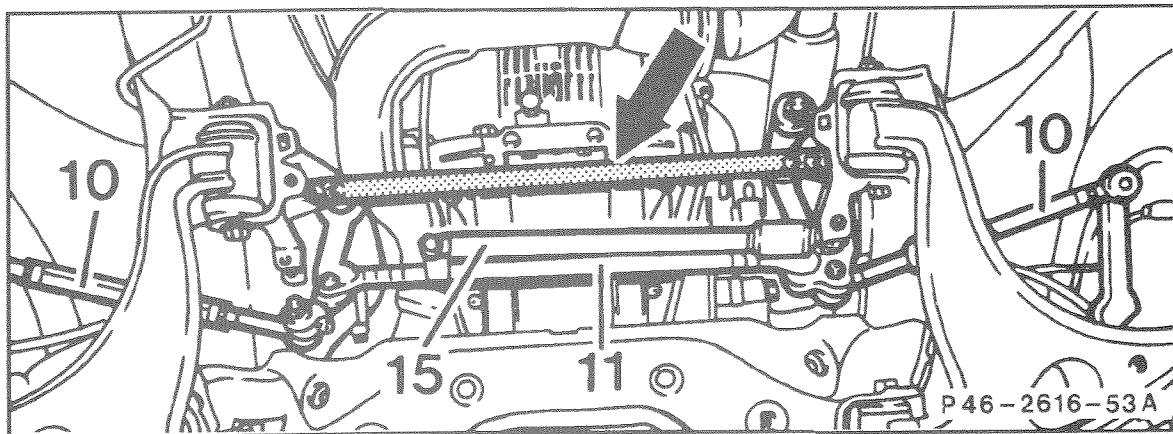

Rear axle

Modified rear axle components

- Reinforced rear axle carrier.
- Modified rear axle center piece mounting.
- 4-arm drive pinion flange with 110 mm bolt circle diameter.
- Rear axle shaft diameter modified with larger inner constant velocity joints.
- Rear axle hub wheel centering flange lengthened by approx. 2 mm (model 124.036).
- Reinforced camber link.
- Track widened by 38 mm (model 124.036).

Rear axle carrier

The rear axle carrier was strengthened to accommodate the high engine torque and adapted to the modified frame floor. The front and rear crossmembers as well as the flexible center piece mount were modified.

Model 124.036

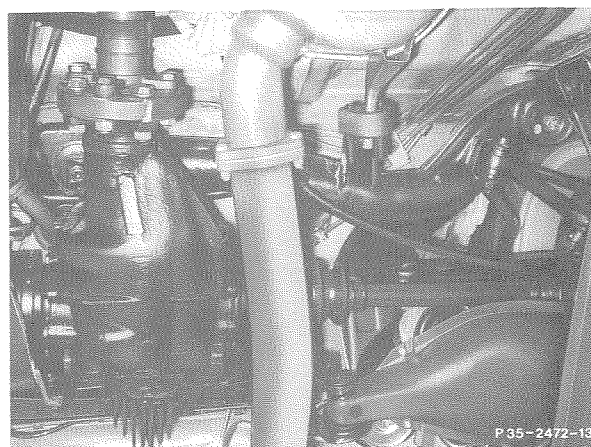

Model 124.034

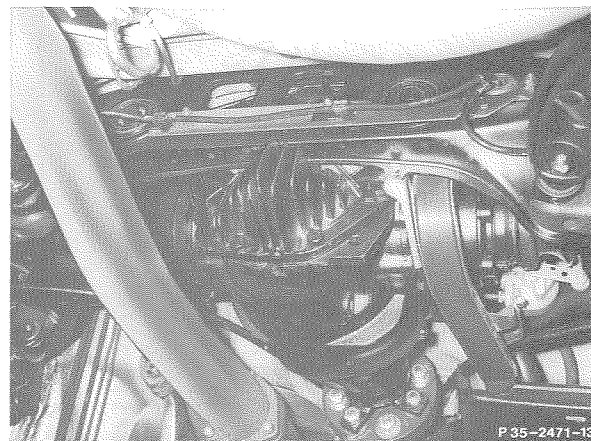

Gear set and rear axle shaft

Model			124.034	124.036	
Rear axle center piece	Ring gear dia.		210	210	
	Ratio		2.24	2.82	
	Number of teeth		47 : 21	48 : 17	
Gear/rotor on drive pinion for ABS	Number of teeth		43	- ¹⁾	
Constant velocity joint flange dia.			110	110	
Constant velocity joint flange type			4-arm	4-arm	
Rear axle shaft with constant velocity joint	Ball dia.	inner	23.812	23.812	
	Ball dia.	outer	22.225	22.225	
	Inner bolt circle dia.		102	102	
	Shaft dia.	without ASR		25	-
		with ASR		32	32
	Grease fill quantity (g)	inner		150	150
	Grease fill quantity (g)	outer		120	120

1) ASR standard equipment, no gear used.

Wheels, chassis measurement, wheel alignment

Cross reference - wheels/tires/recommended tire brands

Model	Rim designation Part no.	Summer tires, tubeless		Winter tires, tubeless	
		Tire size	Brand	Tire size	Brand
124.034	Light alloy 6 1/2 J x 15 H2 ET 44 8-hole design 124 401 12 02	195/65 R15 91V	MICHELIN MXV	195/65 R 15 91 T M + S	CONTINENTAL SUPER CONTACT TS 750 DUNLOP SP WINTER GOODYEAR ULTRA GRIP 3 PIRELLI MS WINTER 190 PERFOR- MANCE
124.036	Light alloy 8 J x 16 H2 ET 34 8-hole design 124 401 14 02	225/55 ZR16	PIRELLI P600 DUNLOP D40 MICHELIN MXM	225/55 R 16 93 H M + S	DUNLOP SP WINTER SPORT PIRELLI MS WINTER 210 PERFOR- MANCE

Light alloy wheel (8-hole design)

Forged light alloy wheel without steel sleeves.
Unlike the 8-hole wheels of model 140, the
wheels for models 124.034/036 are painted.

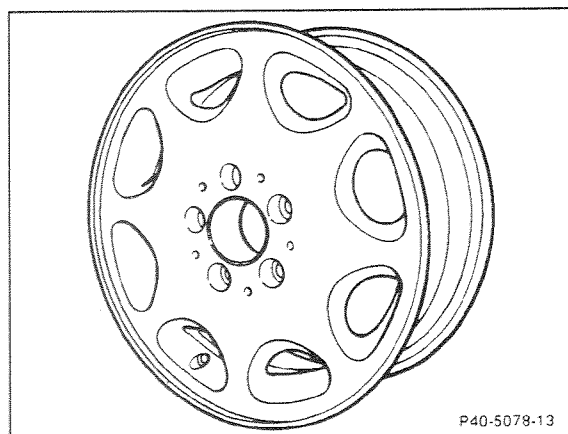

P40-5078-13

Wheel bolts

Model	124.034	124.036
Height of head "K"	22.5	43.5
Bolt shank length "L"	40	40

Note:

Wheel bolts for models 124.034 and 124.036 are not interchangeable.

P40-0034-81

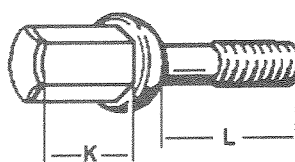

Model 124.034

P40-5051-81

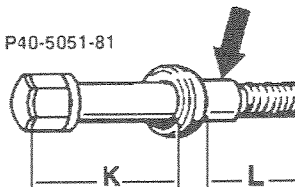

Model 124.036 with fitted shank collar (arrow)

Tire pressures

For tire pressures, see tire inflation pressure label located on inside of fuel filler flap.

Snow chains

Snow chains with RUD-matic gripping stud are available as Mercedes-Benz accessory merchandise.

Model	Part no.	ID no.
124.034	Q6 58 0002	82
124.036	Q6 58 0008	93

The ID no. is stamped on the tensioning chain locking hook or eye.

Chassis measurement (test and adjustment data)

Vehicle level

Model	Front axle	Rear axle with level control	
	vehicle at curb weight mm	vehicle at curb weight ¹⁾ mm	loaded (control point) mm
124.034	+9 \pm $\begin{matrix} 10 \\ -15 \end{matrix}$	+9 \pm $\begin{matrix} 10 \\ -12 \end{matrix}$	-12 \pm $\begin{matrix} 2 \\ 10 \end{matrix}$ ²⁾ -12 \pm 10 ³⁾
124.036	-9 \pm $\begin{matrix} 10 \\ -15 \end{matrix}$	-10 \pm $\begin{matrix} 10 \\ -12 \end{matrix}$	-27 \pm $\begin{matrix} 2 \\ 10 \end{matrix}$ ²⁾ -27 \pm 10 ³⁾

1) Vehicle curb weight adjustment values based on base pressure in damper struts.

2) Adjustment values.

3) Test values only. The difference of the vehicle level between test and adjustment is obtained from the leveling valve travel and has no effect on the control accuracy while driving.

Front axle wheel alignment at specified vehicle level (curb weight)

Model 124.034

Camber ¹⁾	Wheels in straight ahead position (toe 0°)	-0°40' \pm $\begin{matrix} 10' \\ -20' \end{matrix}$	(-0,65° \pm $\begin{matrix} 0,15^\circ \\ -0,35^\circ \end{matrix}$)
	Permissible difference between left and right	0°20'	(0,35°)
Caster ¹⁾	Wheels in straight ahead position (toe 0°)	10°30' \pm 30'	(10,50° \pm 0,50°)
	Measured against wheel stop	10°15' \pm 30'	(10,25° \pm 0,50°)
	Permissible difference between left and right	0°30'	(0,50°)
Toe-in ¹⁾ (front wheels spread with 90–110 N force)		0°20' \pm 10'	(0,35° \pm 0,15°)
Toe-out with inner wheel turned 20° ²⁾		-1° \pm 30'	(-1,00° \pm 0,50°)
Maximum permissible steering angle at inner wheel ³⁾		40°	(40,00°)
Ball point position ⁴⁾	Pitman arm	26.5 \pm 2 mm	
	Idler arm	23.5 \pm 2 mm	
Permissible ball joint height difference between pitman and idler arms		3 mm	

1) Tolerance is for checking only. If out of tolerance, adjust to specified value.

2) Value given does not include toe.

3) Wheel angle on outside wheel will be 7° to 11° less than on inside wheel.

4) Correction is made on idler arm in upward or downward direction by addition or removal of washer.

Note:

Values in parentheses () are in decimal degrees.

**Front axle wheel alignment at specified vehicle level (curb weight)
Model 124.036**

Camber 1)	Wheels in straight ahead position (toe 0°)	$-1^{\circ} \begin{matrix} + \\ - \end{matrix} \begin{matrix} 10' \\ 20' \end{matrix}$	$(-1,00^{\circ} \begin{matrix} + \\ - \end{matrix} \begin{matrix} 0,15^{\circ} \\ 0,35^{\circ} \end{matrix})$
	Permissible difference between left and right	0°20' (0.35°)	
Caster 1)	Wheels in straight ahead position (toe 0°)	$10^{\circ}50' \pm 30'$	$(10.85^{\circ} \pm 0.50^{\circ})$
	Measured against wheel stop	$10^{\circ}35' \pm 30'$	$(10.60^{\circ} \pm 0.50^{\circ})$
	Permissible difference between left and right	0°30' (0.50°)	
Toe-in ¹⁾ (front wheels spread with 90–110 N force)		$0^{\circ}20' \pm 10'$	$(0.35^{\circ} \pm 0.15^{\circ})$
Toe-out with inner wheel turned 20° 2)		$-0^{\circ}55' \pm 30'$	$(-0.90^{\circ} \pm 0.50^{\circ})$
Maximum permissible steering angle on inner wheel 3)		40°	(40.00°)
Ball point position 4)	Pitman arm	26.5 ± 2 mm	
	Idler arm	23.5 ± 2 mm	
Permissible ball joint height difference between pitman and idler arms		3 mm	

1) Tolerance is for checking only. If out of tolerance, adjust to specified value.

2) Value given does not include toe.

3) Wheel angle on outside wheel will be 7° to 11° less than on inside wheel.

4) Correction is made on idler arm in upward or downward direction by addition or removal of washer.

Note:

Values in parentheses () are in decimal degrees.

Propeller (drive) shaft

Survey

Model		124.034/036
Drive shaft tube dia. (mm)	front	60 mm
	rear	60 mm
Drive shaft flange bolt circle dia. (mm)		110 mm/4-arm flange
Flex disc	front	torsionally rigid
	rear	torsionally rigid
Centering sleeve	front	rubber bushing
	rear	composite bushing
Centering sleeve installation depth (mm)	front	22.4 mm
	rear	25.9 mm

ABS

Model 124.034

The ABS system, known from model 124, was revised and modified to include the following changes. The ABS control unit (N30) is now equipped with diagnostics. Recognized malfunctions are stored in the control unit and retrieved via the 38-pole test connection for diagnosis (impulse readout, X11/4) using an impulse counter. Malfunctions can be subsequently diagnosed with the socket box tester. For the ABS test, see Diagnostic Manual, Chassis and Drivetrain, Volume 1, Section 6.2, Model 140.

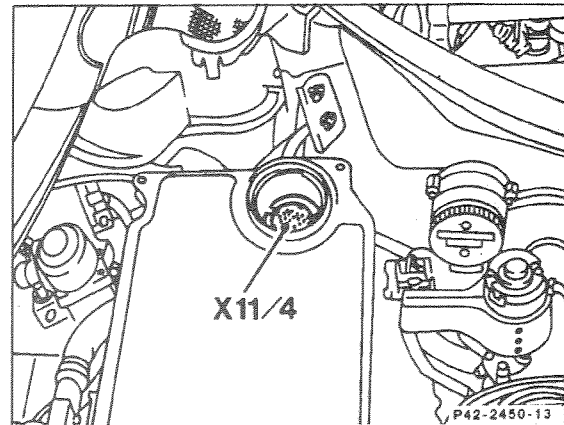

Voltage is supplied by the base module (N16/1). The base module (N16/1) and the ABS control unit (N30) are located in the module box. On model 124.034 with optionally available ASR, the ABS control unit (N30) is replaced by the ABS/ASR control unit (N30/1).

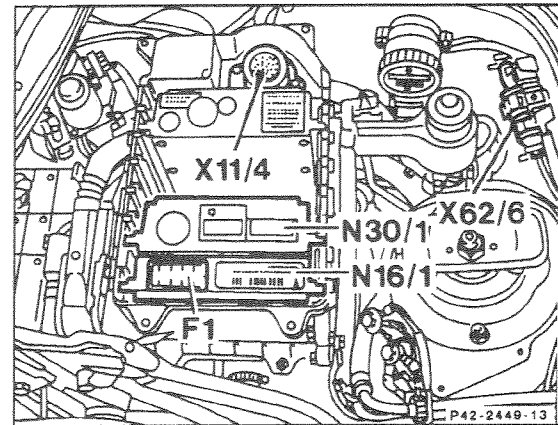

Acceleration slip control (ASR III)

Model 124.034 optional equipment

Model 124.036 standard equipment

The acceleration slip control, known from model 129 (ASR II), has been revised and is now known as ASR III (3rd version). All modifications are described in the following section.

Modifications to the electronic accelerator system are described in group 30 of this introduction manual.

The ABS/ASR control unit was revised and modified. The ABS/ASR control unit (N30/1) is now equipped with diagnostics. Recognized malfunctions are stored in the control unit and retrieved via the 38-pole test connection for diagnosis (impulse readout, X11/4) using an impulse counter. Malfunctions can be subsequently diagnosed with the socket box tester. For the ASR test, see Diagnostic Manual, Chassis and Drivetrain, Volume 1, Section 5.2, Models 124.036, 140.

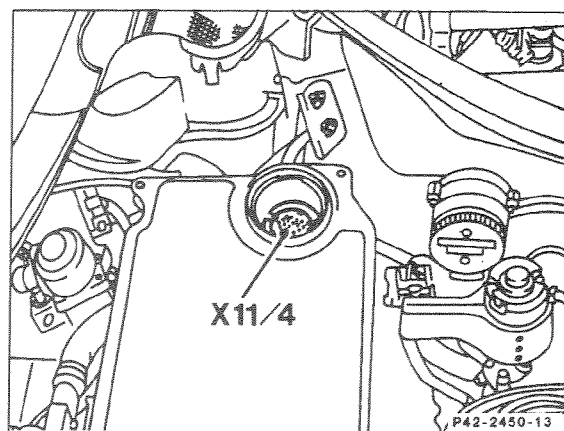

Voltage is supplied by the base module (N16/1). The base module (N16/1) and the ABS/ASR control unit (N30/1) are located in the module box.

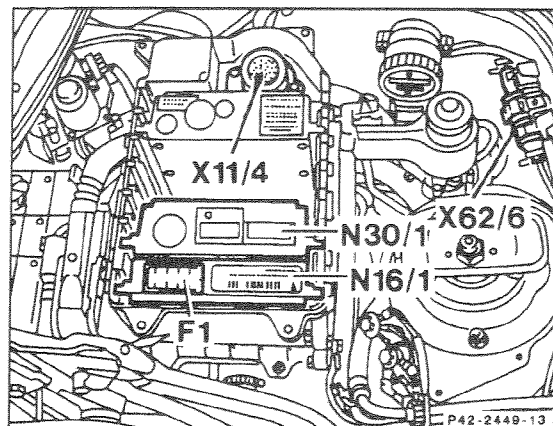

Steering

Steering gear

Steering gear 765.921 (LSL 068) is identical to the version used in model 129, except for a lower mounting position.

Steering ratio = 14.0 - 15.0

- 1 Steering gear housing
- 4 Control valve
- 5 Reaction piston
- 8 Cover
- 13 Steering worm
- 25 Steering nut
- 35 Steel balls
- 43 Pitman shaft
- 45 Adjusting screw
- 50 Self-locking collar nut
- 51 Housing cover
- 71 Screw plug
- 91 Automatic end play compensation
- 100 Screw plug

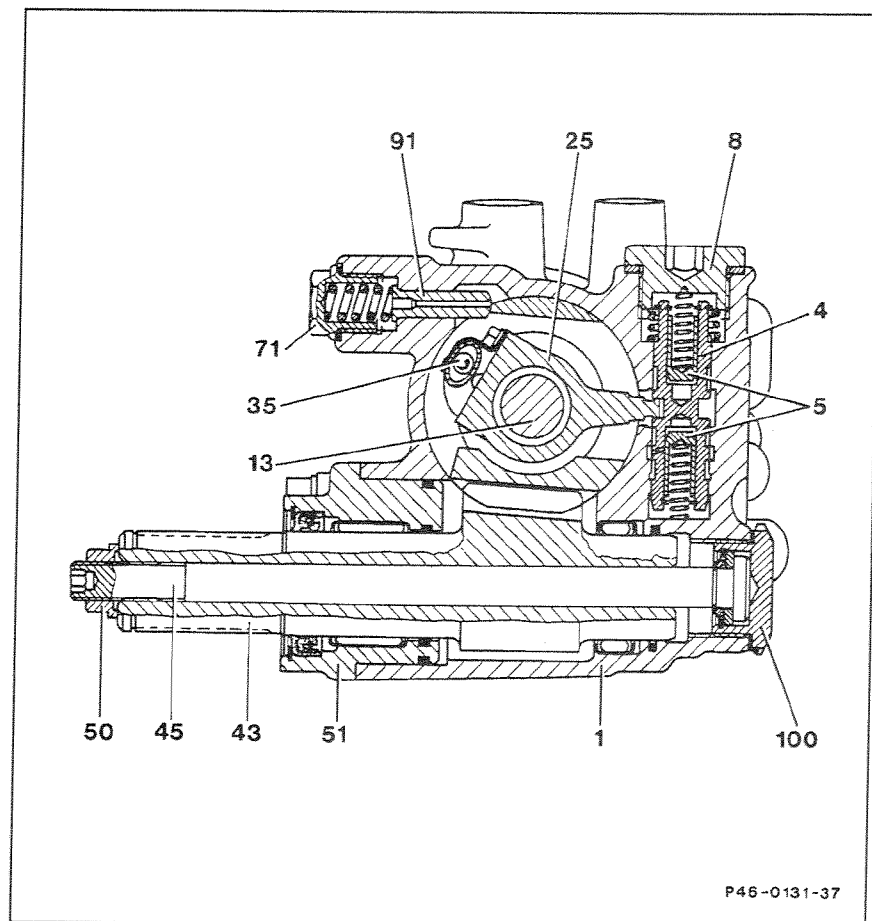

P46-0131-37

Steering column jacket tube/steering spindle

An electrically adjustable telescoping steering column is installed as a standard equipment and is connected to the steering gear by a universal joint (2).

To center the steering box, align the pinch slot of the steering column universal joint (2a) with the centering mark engraved on the steering box (arrows).

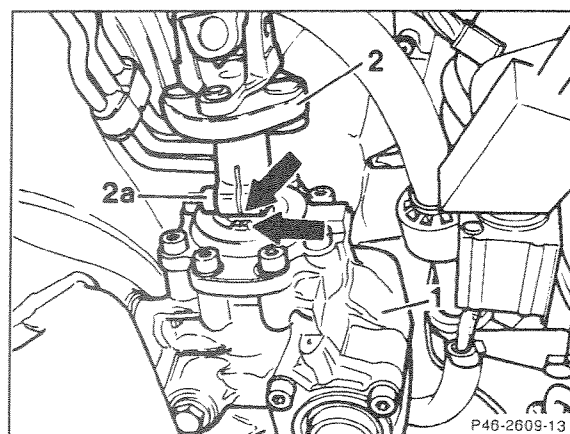

Steering wheel (140-design)

Both models are equipped with a newly designed leather covered steering wheel with airbag.

Steering wheel diameter:

Model 124.034 400 mm,

Model 124.036 390 mm.

Correct positioning of the steering wheel during installation is assured by two grooves in the hub (arrows) and by a mark on the steering shaft spindle.

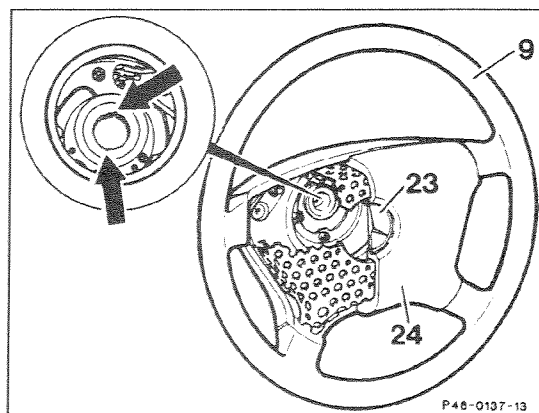

Steering geometry, steering linkage

The steering linkage was modified due to the increased front axle load. The left tie rod is fitted with a hexagonal adjusting tube.

The right tie rod is known from model 129.

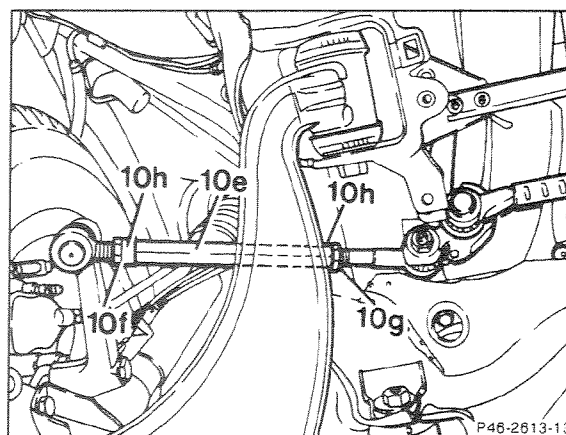

In order to protect the steering linkage joint from high engine temperatures, a heat shield (12a) was mounted on the pitman arm.

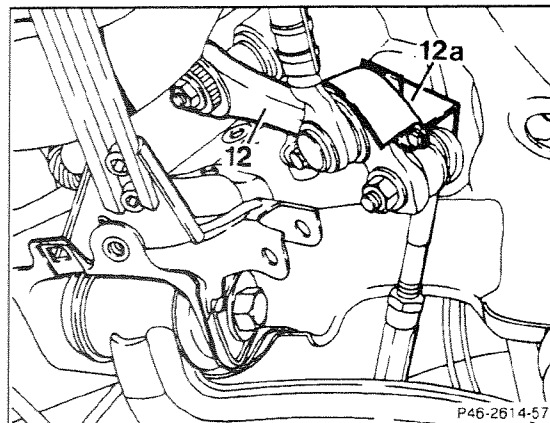

Fuel system

Fuel tank

Model 124.036

The capacity of the fuel tank is approx. 90 liters (23.8 gal.), of which approx. 11.5 liters (3.0 gal.) are reserve.

Electrical system – equipment and instruments

Battery

12 V, 100 A, maintenance-free.

Battery location in right side of trunk

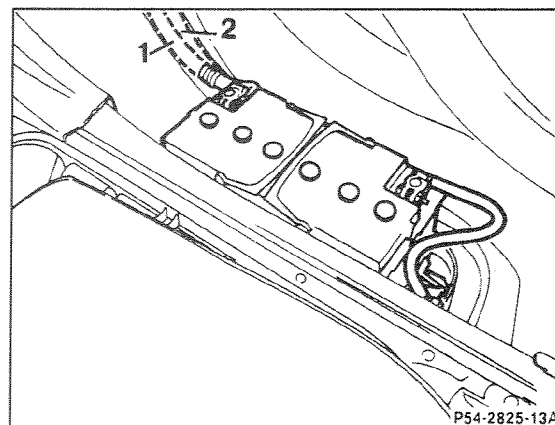

Note:

Battery testing should be performed according to SMS, Repair Instructions, Group 54.

Battery positive cable

There are two battery positive cables having respective cross sections of 70 mm² and 10 mm².

Battery positive cable (70 mm²)

With the exception of control units in the module box, all electrical consumers are supplied with voltage from the 70 mm² battery positive cable.

Battery positive cable (10 mm²)

Control units in the module box are supplied with voltage from the 10 mm² battery positive cable.

Routing of battery positive cables

The 70 mm² battery positive cable runs from the battery to terminal block (X4/10). The 10 mm² battery positive cable runs from the battery directly to the module box.

The cables are routed inside the vehicle, along the right longitudinal frame rail.

- 1 70 mm² battery positive cable
- 2 10 mm² battery positive cable

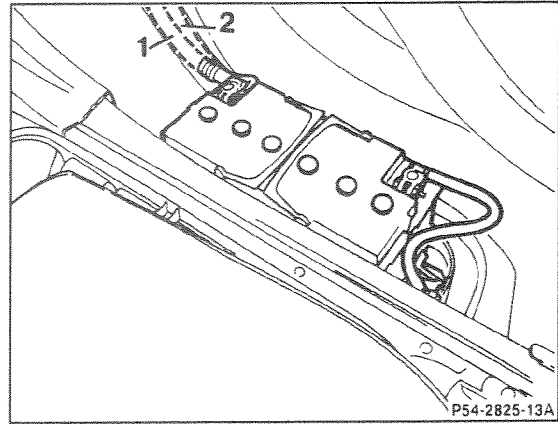

- 1 70 mm² battery positive cable
- 2 10 mm² battery positive cable

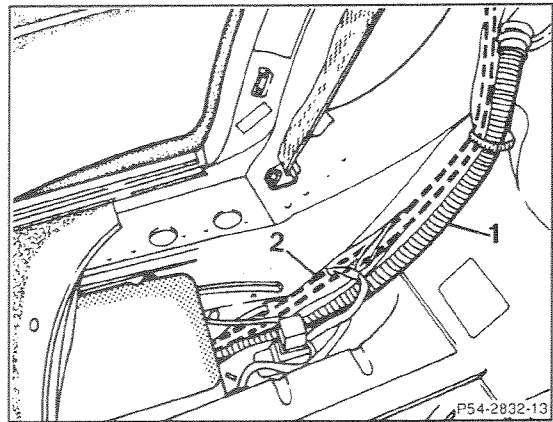

X4/10 Terminal block, terminal
30/30Ü/61e/87L (5-pole)

- 1 70 mm² battery positive cable
- 2 10 mm² battery positive cable

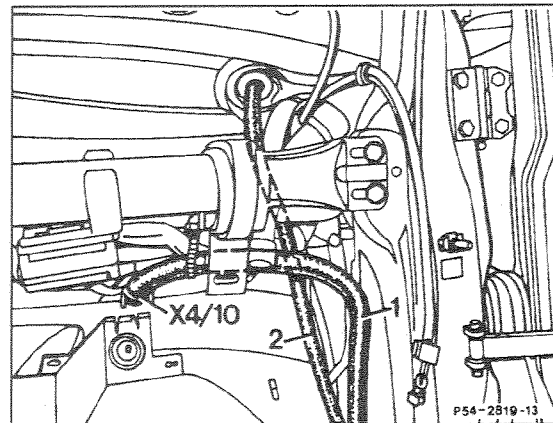

Terminal block (X4/10)

The alternator, starter and alternator noise suppressor are connected to the 70 mm² battery positive cable via terminal block (X4/10).

Location in right side of component compartment

C2 Electrolytic capacitor
(alternator/battery harness noise suppressor)

X4/10 Terminal block,
terminal 30/30Ü/61e/87L (5-pole)

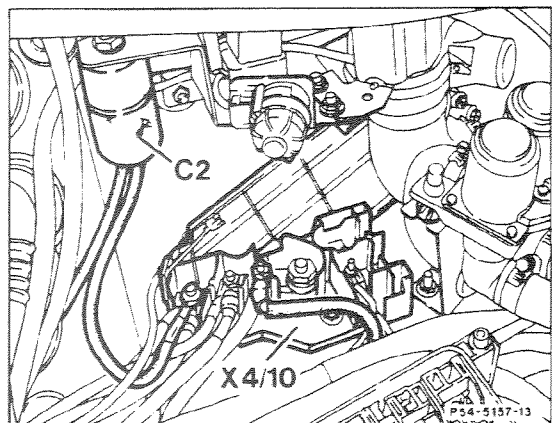

Electrolytic capacitor (C2)

A 4700 μF electrolytic capacitor (C2) is installed for noise suppression of electrical interference from the 70 mm² battery positive cable.

The capacitor's positive (+) connection is made at terminal block X4/10 (70 mm² battery positive cable), and the negative (-) connection is made at ground location W16/2.

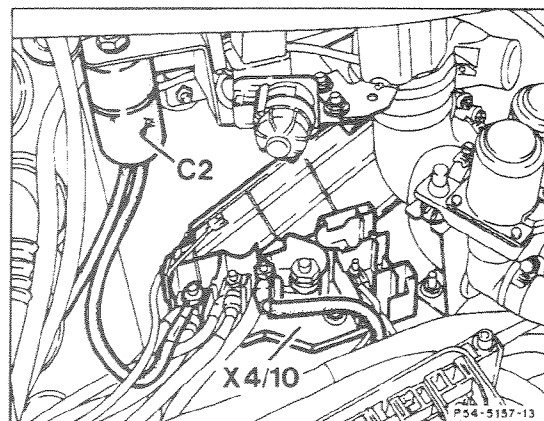

- C2 Electrolytic capacitor (alternator/battery harness noise suppressor)
 X4/10 Terminal block, terminal 30/30Ü/61e/87L (5-pole)

Module box (F23)

In order to protect the control units in the engine/component compartment, and fit them into a compact area, the electronic control units are installed in a module box (F23).

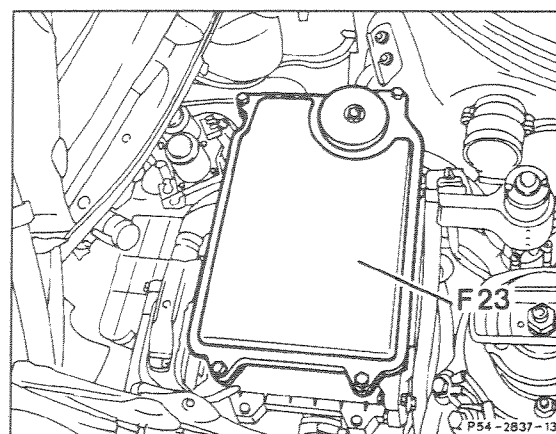

F23 Module box

Control units in the module box (F23) are cooled by a blower motor (M2/2). Cool intake air is drawn from the passenger compartment in the glove box area and is later returned to the same area.

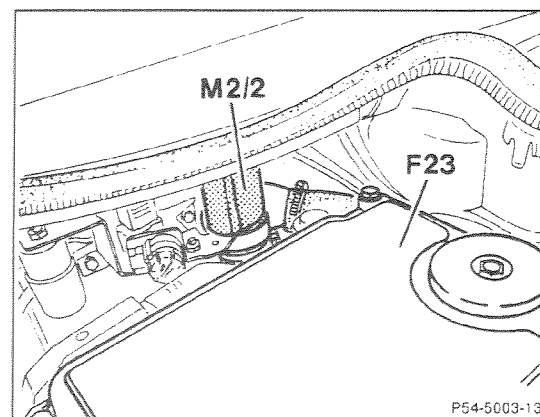

M2/2 Module box blower motor

The blower motor (M2/2) is switched on and off by a temperature sensor integrated in the base module (N16/1).

The blower motor (M2/2) is switched on:

- For 1.5 seconds after each engine start if the engine speed exceeds 1200 rpm.
- If the temperature in the module box is $\geq +60\text{ }^{\circ}\text{C}$.

The blower (M2/2) is switched off at temperatures $\leq +55\text{ }^{\circ}\text{C}$.

If the temperature in the module box exceeds a specified limit while driving (in spite of blower motor [M2/2] operation), the base module (N16/1) diagnostics stores this information as a malfunction (impulse readout 5). For further information, see Diagnostic Manual, Chassis and Drivetrain, Volume 1.

Location of control units in module box (F23)

N3/1	LH control unit
N4/1	Electronic accelerator control unit
N16/1	Base module
N30/1	ABS/ASR control unit

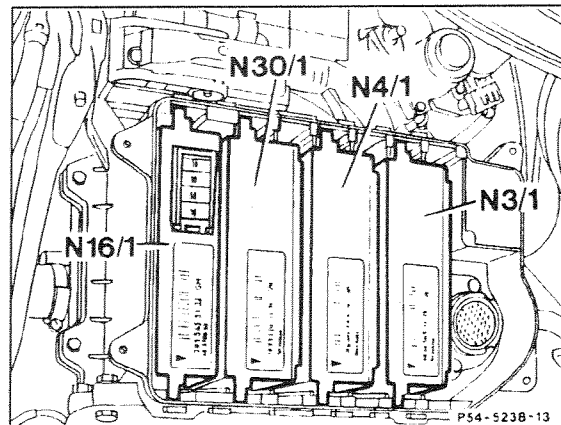

All control units and connectors in the module box are equipped with a safety feature to prevent the control unit from being plugged into the wrong connector. In addition, the control units are color coded. A color identification mark (arrow) on each control unit is identical to the color of its respective connector in the module box.

Several control units have 2 connector blocks, whereby the connector for the second connector block is darker in color than the color identification mark on the control unit.

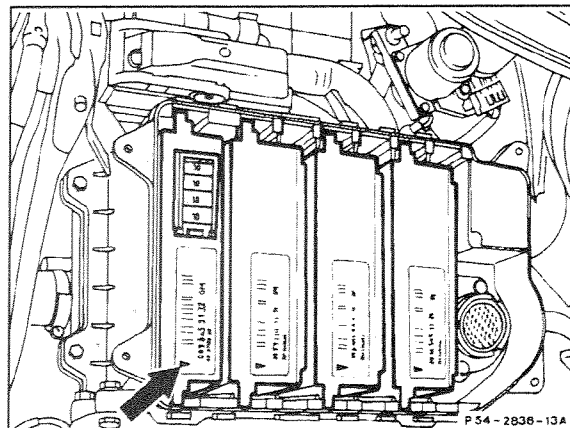

The individual connection fields in the module box are identified by number. This, along with the color-coded connectors, allows easy coordination

of the wiring harness with the respective connection field and control unit.

Control unit coordination

Control unit color mark	Connection field number	Identification color of harness connector
N3/1 LH control unit light green	6 7	light green dark green
N4/1 Electronic accelerator control unit light orange	4 5	light orange dark orange
N16/1 Base module black	1	black
N30/1 ABS/ASR control unit light grey	2 3	light grey dark grey

Removal and installation of control units

Note:

A special tool, part no. 140 589 01 33 00, is required for the removal/installation of control units in the module box.

Special tool

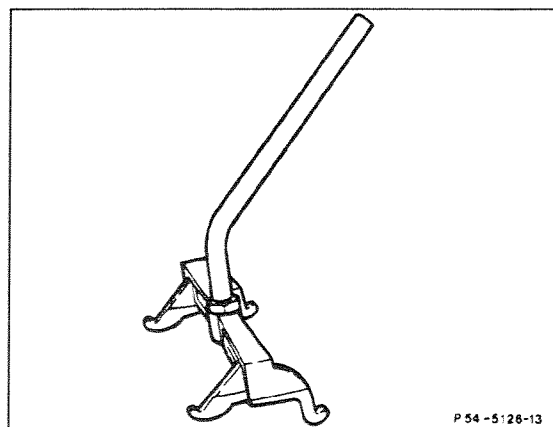

P 54 -5/26-13



Phil Smart Inc.

600 E. Pike
Seattle, WA 98122

1. Disconnect and cover battery negative terminal.
2. Unscrew module box cover screws and lift off cover.

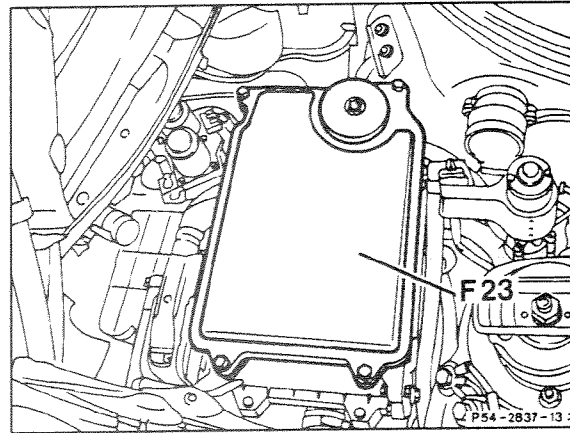

3. Place special tool on control unit (arrows) and carefully move in direction of arrow until the control unit lifts out of connector.
4. Remove special tool and pull out control unit.

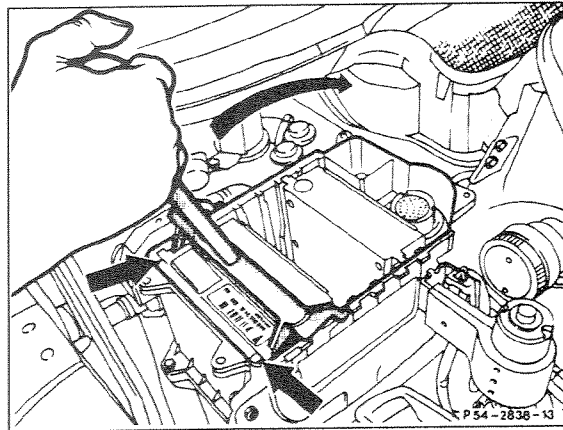

5. Insert control unit by hand, paying attention to the color coding.
6. If necessary, press control unit completely in with special tool by placing special tool on module box frame under the ribs (arrow). Carefully move special tool in direction of arrow until resistance can be felt when control unit is fully engaged in connector.
7. Remove special tool.

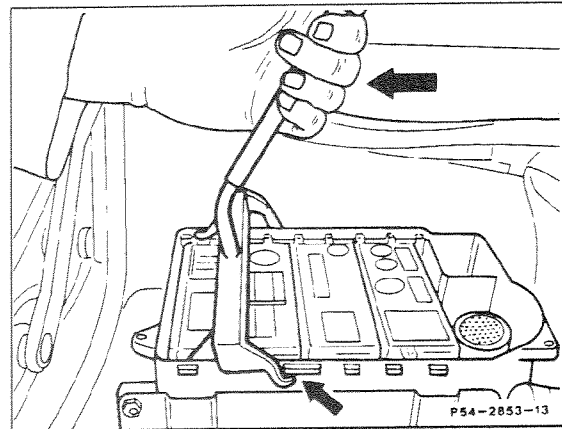

8. Further installation is in reverse order of removal.



38-pole test connection for diagnosis (X11/4)

The 38-pole test connection for diagnosis (impulse readout) is integrated into the module box (F23) and accessible after removal of a cover. Diagnosis of individual systems is covered in the respective diagnostic manuals.

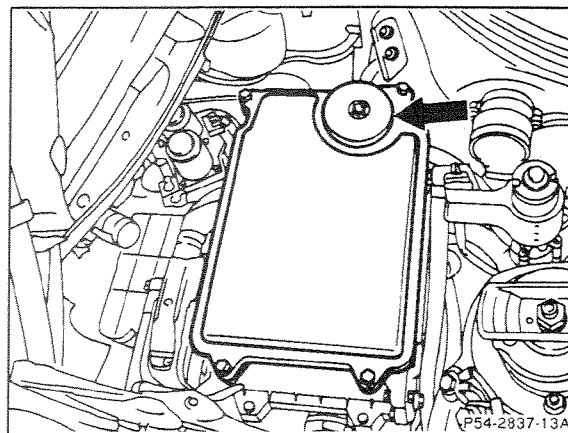

Terminal layout of 38-pole test connection for diagnosis (X11/4)

- | | |
|-------|---|
| 1 | Terminal 31 (ground)
W12, W15a (electronics
ground) |
| 2 | Supply voltage, terminal 87 |
| 3 | Terminal 30 |
| 4 | LH control unit, (N3/1) * |
| 5 | Not used |
| 6 | ABS/ASR control unit
(N30/1) * |
| 7 | Electronic accelerator
control unit (N4/1) * |
| 8 | Base module (N16/1) * |
| 9-15 | Not used |
| 16 | ACC pushbutton control
unit (N22) ** |
| 17 | EZL/AKR ignition
control unit (N1/3) * |
| 18-29 | Not used |
| 30 | SRS control unit
(N2/2) ** |
| 31-38 | Not used |

* Diagnostic capability via
serial interface

** Impulse readout (blink
code) only

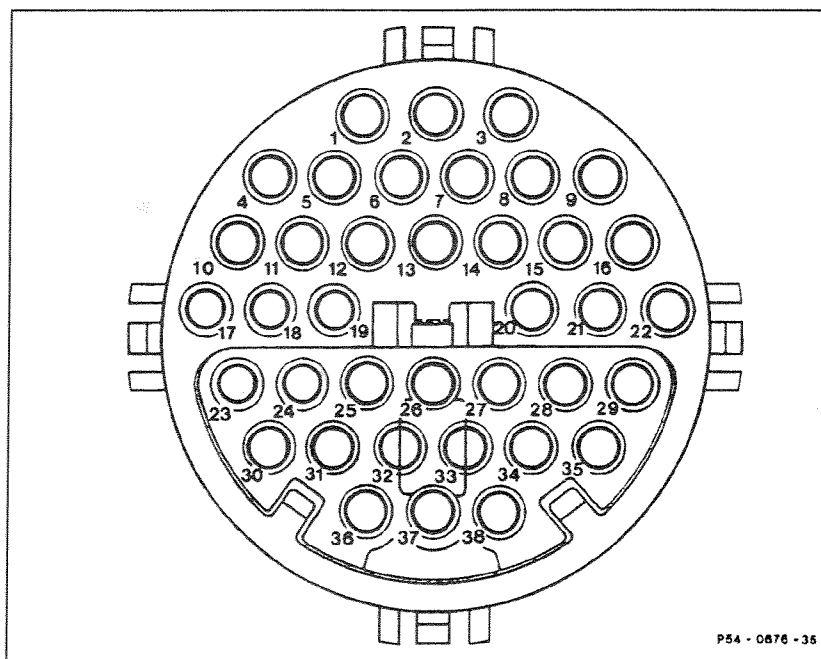

Instrument cluster

CHECK ENGINE warning lamp (A1e26)

California version model 124.034 vehicles and all model 124.036 vehicles are equipped with the CHECK ENGINE warning lamp.

Federal version model 124.034 vehicles are not equipped with a CHECK ENGINE warning lamp.

Electronic speedometer

The speed signal for the speedometer is provided by an inductive speed sensor (L2) on the transmission.

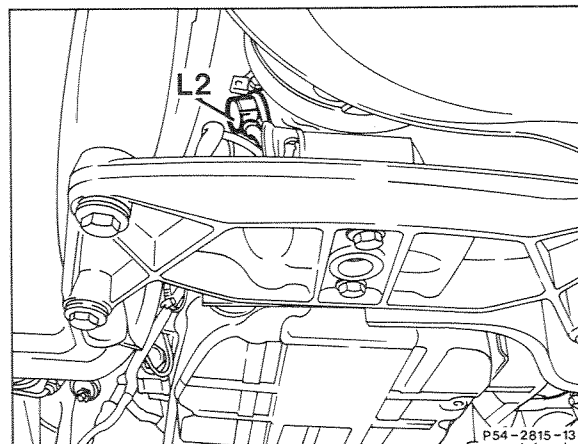

Fuel level indicator

Model 124.036

The fuel level indicator and the fuel level sensor were adapted to the larger fuel tank (90 liters/ 23.8 U.S. gal.) and increased reserve capacity (approx. 12 liters/3.2 U.S. gal.).

Test values for fuel level sensor

Model 124.036

Installed,
reserve indicator ON, float at bottom:
0–8.1 Ω .

Sensor rotated 180°,
indicator at "FULL", float at top:
79–82 Ω .

Two-tone fanfare horns

Two-tone fanfare horns are installed as standard equipment. Unlike previous models with fanfare horns, the standard signal horns and respective selection switch are not installed.

H2 Fanfare horn 1

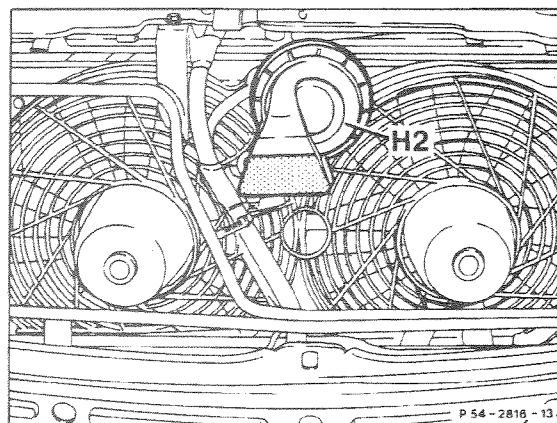

E5/2 Right fog lamp
H2/1 Fanfare horn 2

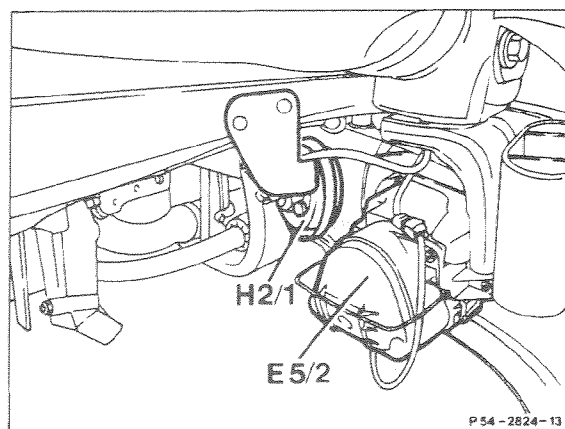

The ellipsoid fog lamps are installed below the front bumper in the spoiler area.

The ellipsoid fog lamps operate according to the projection principle in which light is not emitted through a dispersion lens but instead through a focusing lens.

The advantages are a more compact assembly and an extremely sharp beam cut-off. This results in wide beam dispersion and reduced glare.

Repair note:

Models 124.034/036

To adjust the left or right headlamp or to replace a bulb, it is necessary to remove the engine air intake housing.

Air intake housing removal/installation

- Pull off hose to air filter from air intake housing.
Additionally on left air intake housing, unplug connector for intake air temperature sensor.
- Lift up straps on air intake housing and guide them over both catches (arrows), thereby lifting out the air intake housing to the top.
- Installation is in reverse order of removal.

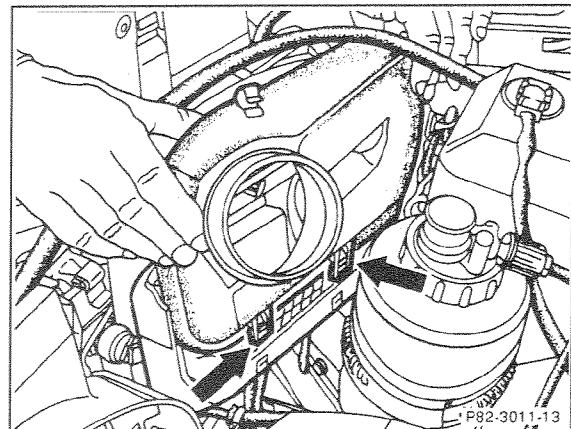

Windshield wiper system

Model 124.036

The range of the extended-reach wiper in its outermost position was increased by 4 mm.

Interior lighting

Rear reading lamps are installed as standard equipment.

Detachable body components

Bumpers

Model 124.036

The front bumper cover was reshaped to reduce front axle lift by nearly one half.

The fog lamps are located to the left and right of the modified front bumper ventilation slits, similar to model 129.

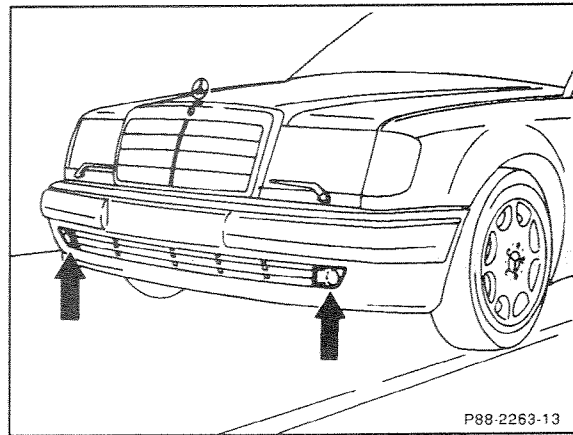

The rear bumper cover was modified to fit the widened rear fenders.

Front and rear bumpers constructed with energy absorbing foam and integrated impact absorbing bumper struts as known from previous model 124 vehicles.

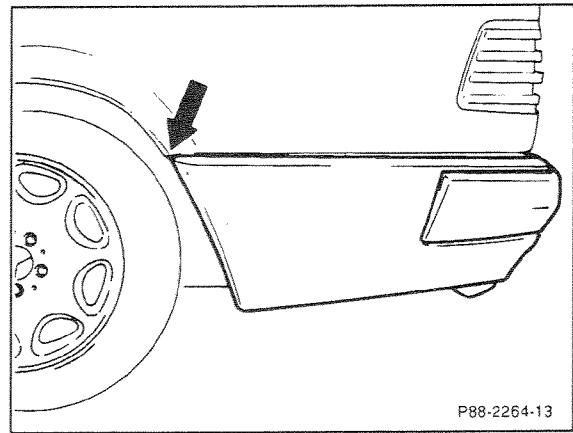

Front fenders

Model 124.036

The front fender arches were flared outwards to accommodate wider tires.

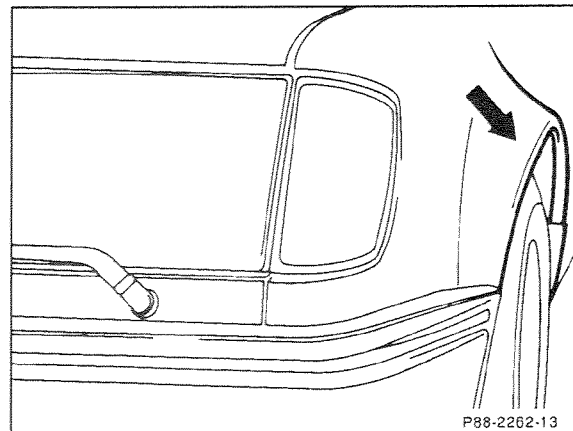

Exterior panels

Model 124.036

The front and rear fender side protection panels as well as the rocker panel covers were adapted to fit the modified front and rear fender contours.

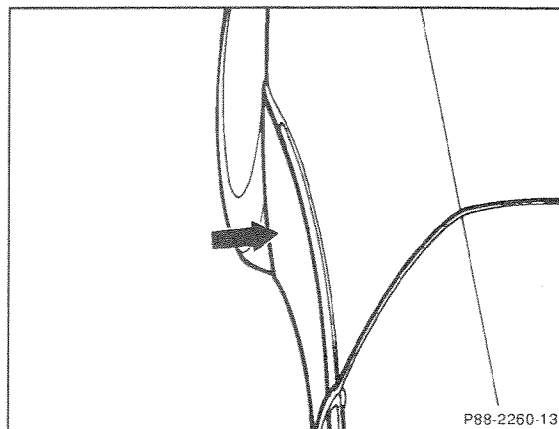

Trunk

Model 124.036

Due to a larger 90 liter (23.8 U.S. gal) fuel tank, the trunk volume was decreased from 520 liters to 485 liters.

Seats, restraint systems

Seats

Model 124.036

Sport 4-place leather seating is installed and is available in the following interior colors: creme beige, black, blue, dark brown and grey. Due to the individual rear seating, model 124.036 is classified as a four seater only.

Airbag

Model 124.034

As previously, a driver airbag is installed as standard equipment. A front passenger airbag is optionally available.

Model 124.036

Driver and front passenger airbags are installed as standard equipment.

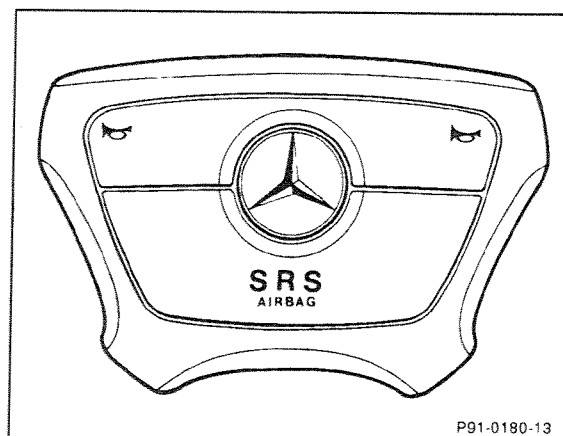

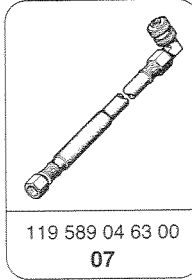
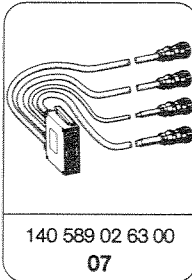
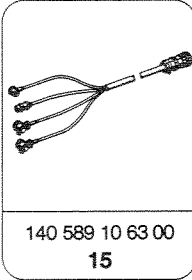
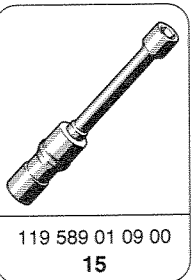
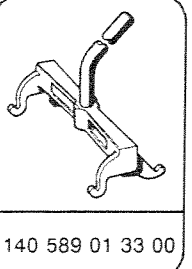
Part number Description	Group	Category	
119 589 04 63 00 Pressure hose with angular connection $7/16"$ - 20 UNF and union nut M12 \times 1.5 mm for LH gasoline injection system (with tester 103 589 00 21 00).	07	A	 119 589 04 63 00 07
140 589 02 63 00 Contact module 2 LH gasoline injection system, ABS/ASR, electronic accelerator system.	07	B	 140 589 02 63 00 07
140 589 10 63 00 18-pole test cable for EZL/AKR ignition system.	15	B	 140 589 10 63 00 15
119 589 01 09 00 Spark plug wrench $5/8"$ (15.8 mm) 175 mm long, $3/8"$ square drive.	15	A	 119 589 01 09 00 15
140 589 01 33 00 Lifting fixture for removal/installation of control units in module box.	54	A	 140 589 01 33 00

Special tools

Part number Description	Group	Category	
140 589 01 63 00 Contact module 1 for base module.	54	B	 140 589 01 63 00 54
140 589 06 63 00 Contact box for checking control units in module box.	54	B	 140 589 06 63 00 54
140 589 14 63 00 Adaptor for diagnostic test connection for connecting impulse counter 124 589 19 21 00 to diagnostic test connection.	54	B	 140 589 14 63 00 54
140 589 10 33 00 Spacer for removal of control units from contact box.	54	B	 140 589 06 63 00
129 589 00 21 00 126-pole socket box for checking electronic systems in conjunction with contact module.	83	B	 129 589 00 21 00 54

