

Service Manual

Section
2

Group
25

Construction and function

Emission Control
Systems
240/260
1976-

VOLVO

Table of Contents
EMISSION CONTROL SYSTEMS
(240/260 1975-)

	Page
General	
Applications Chart (US)	2
Applications Chart (Canada)	3
Catalytic Converter	4
Oxidation Converter	
Three-Way Converter	
Crankcase Emission Control System	6
Components	
Component Placement	
Evaporative Emission Control System	9
Components	
Component Placement	
Air Injection Reactor	16
Components	
Component Placement	
Altitude Compensating Control Pressure Regulator	19
Components	
Component Placement	
Exhaust Gas Recirculation	21
Components	
Component Placement	
Pulsair System	26
Components	
Lambda Sond System	27
Components	
Component Wiring/Placement 240-series 1977	
Component Wiring/Placement 240-series 1978	
Component Wiring/Placement 260-series 1978	
Component Wiring/Placement 240-series 1979	
Component Wiring/Placement 260-series 1979	
Component Wiring/Placement 240-series; B21F engine 1980	
Component Wiring/Placement 260-series; B28F engine 1980	
Component Wiring/Placement 240-series; B21F engine 1981	
Component Wiring/Placement 240-series; B21F-Turbo 1981	
Component Wiring/Placement 260-series; B28F engine 1981	
Component Wiring/Placement 240-series; B21F engine 1982	
Component Wiring/Placement 240-series; B21F-Turbo 1982	
Component Wiring/Placement 260-series; B28F engine 1982	
Component Wiring/Placement 240-series; B21F-Turbo 1983	
Component Wiring/Placement 240-series; B23F engine 1983	
Component Wiring/Placement 240-series; B23F engine 1984	
Component Wiring/Placement 240-series; B21F-Turbo 1984	
Component Wiring/Placement 240-series; B230F engine 1985	
Component Wiring/Placement 240-series; B21F-Turbo 1985	
Diesel Emission Controls	66
Tune-Up Specifications	

Order Number: TP 30727/1

We reserve the right to make alterations
without prior notification.

©1985, VOLVO OF AMERICA CORPORATION

Emission Control Systems General

Volvo employs a variety of mechanical, electrical, and electromechanical systems designed to reduce the amount of pollutants found in the exhaust emissions.

The systems listed below vary in application across model years and engine types. Use applications charts on the pages that follow for information on specific applications.

- Evaporative Control System
- Crankcase Emission Control System
- Lambda-Sond™ System
- Catalytic Converter
- Altitude Compensating Control Pressure Regulator
- Exhaust Gas Recirculation
- Air Injection Reactor

The increasing stringency in emission control requirements mandated by Federal and State governments have effected changes in emission control technology since the 1975 model year. The California Air Resources Board (CARB) has set unique exhaust emissions standards for cars sold in California; this is why the emission control equipment may vary with engine type within a model year.

This manual describes the construction and function of the emission controls that were incorporated to meet the emission requirements for each model year and model. Refer to other service literature, i.e. service manuals, for the adjustments and fault tracing of emission control equipment.

Emission Controls, Design & Function

-Applications Chart-

U.S. 240/260 Series

Year	Model(s)	Engine Type	Exhaust Gas Recirculation	Air Injection Reactor	Catalytic Converter 3-Way	Catalytic Converter 2-Way	Crankcase Emission Control System	Altitude Compensating Regulator	Evaporative Control System	Lambda-Sond
1975	242, 244, 245	B20F	x	•	x	•				
1976	242, 244, 245	B21F	x	•	x	•				
1976	262, 264, 265	B27F	x	•	x	•	x	•	x	•
1977	242, 244, 245	B21F	x				x	•	x	•
1977	262, 264, 265	B27F	x				x	•	x	•
1978	242, 244, 245	B21F	x				x	•	x	•
1978	242, 244, 245	B21F			x		x	•	x	•
1978	262, 264, 265	B27F	x				x	•	x	•
1978	262, 264, 265	B27F			x		x	•	x	•
1979	242, 244, 245	B21F	x				x	•	x	•
1979	242, 244, 245	B21F			x		x	•	x	•
1979	262, 264, 265	B27F			x		x	•	x	•
1980	242, 244, 245	B21F			x		x	•	x	•
1980	262, 264, 265	B28F			x		x	•	x	•
1981	242, 244, 245	B21F A)			x		x	•	x	•
1981	242, 244, 245	B21F - Turbo			x		x	•	x	•
1981	262, 264, 265	B28F B)			x		x	•	x	•
1981	264, 265	D24					x	•	x	•
1982	242, 244, 245	B21F C)			x		x	•	x	•
1982	242, 244, 245	B21F - Turbo			x		x	•	x	•
1982	264	B28F			x		x	•	x	•
1982	244, 245	D24					x	•	x	•
1983	242, 244, 245	B23F			x		x	•	x	•
1983	242, 244, 245	B21F - Turbo			x		x	•	x	•
1983	244, 245	D24					x	•	x	•
1984	242, 244, 245	B23F			x		x	•	x	•
1984	242, 244, 245	B21F - Turbo			x		x	•	x	•
1984	244, 245	D24					x	•	x	•
1985	244, 245	B230F			x		x	•	x	•
1985	244, 245	B21F - Turbo			x		x	•	x	•

- x U.S. (49 state) A) Includes B21F, B21F-MPG
- California B) Includes B28F, B28F w/CIS
- C) Includes B21F, B21F-LH

CANADA 240/260 Series

Year	Model(s)	Engine Type	Exhaust Gas Recirculation	Air Injection Reactor	Catalytic Converter 3-Way	Catalytic Converter 2-Way	Crankcase Emission Control System	Altitude Compensating Regulator	Evaporative Control System	Lambda-Sond	Pulsair
1975	242, 244, 245	B20F									
1976	242, 244, 245	B21F									
1976	262, 264, 265	B27F									
1977	242, 244, 245	B21F		•							
1977	262, 264, 265	B27F		•							
1978	242, 244, 245	B21F		•							
1978	245	B21A	x	•							
1978	245	B21A									•
1978	262, 264, 265	B27F									
1978	264, 265	B27A	x		x	•			x	•	
1979	242, 244, 245	B21A	x								
1979	242, 244	B21F									
1979	262, 264, 265	B27F			x	•			x	•	
1980	242, 244, 245	B21F									
1980	262, 264, 265	B28F			x	•			x	•	
1980	244	B21A	x								x •
1981	242	B21A	x								x •
1981	244, 245	B23E									x •
1981	262, 264, 265	B28F			x	•			x	•	
1981	264, 265	D24									
1982	242	B21A	x	•							
1982	244, 245	B23E	x	•							
1982	262, 264, 265	B28F			x	•			x	•	
1982	244, 245	D24									
1983	242	B21A									x •
1983	244, 245	B23E									•
1983	242, 244, 245	B21F - Turbo			x	•			x	•	
1983	244, 245	D24									
1984	242	B21A	x	•							•
1984	244, 245	B23F			x	•			x	•	
1984	242, 244, 245	B21F - Turbo			x	•			x	•	
1983	244, 245	D24	x	•							
1985	244, 245	B230F			x	•				•	
1985	244, 245	B21F - Turbo			x	•			x	•	

x with automatic transmission

• with manual transmission

CATALYTIC CONVERTER

General

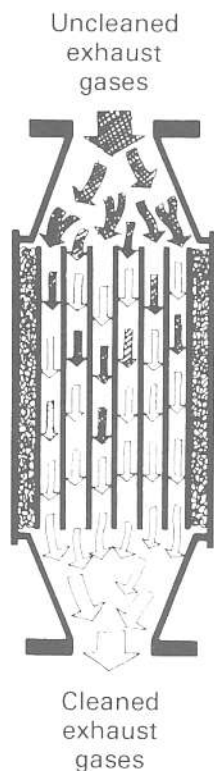

Catalytic Converter

This is a supplementary device in the exhaust system, designed to clean up the remaining unclean exhaust gases.

This device is mainly a steel container with a ceramic material insert, designed to let the exhaust gases pass through channels in the insert. The channel walls are covered by a thin layer of metals. These metals act as catalysts, permitting a chemical action to occur without actually taking part in it.

Damage to the catalytic converter will increase exhaust gas emissions. Additives to fuel and lubricating oil will impair the converter operation. Even short periods of operation with fuel containing lead additives will cause the catalytic converter to partly or completely lose its effectiveness.

At extremely high temperatures in the converter (more than $1400^{\circ}\text{C}=2500^{\circ}\text{F}$) the ceramic body melts. At 1000°C (1800°F), the converter effectiveness will be impaired because the active catalytic surface decreases.

Component Types

Oxidation-Type (Two-Way) Catalytic Converter

This is the standard type of catalytic converter. It will oxidize carbon monoxide (CO) and hydrocarbons (HC) in the exhaust gases by subjecting them to combustion by using extra air. The end products are carbon dioxide and water which are blown out by the exhaust system. This type of catalytic converter will convert only a small amount of the nitrogen oxides (NO_x).

Combustion of carbon monoxide and hydrocarbons is normally achieved in an environment with a high content of oxygen and at a temperature of 650°C (1200°F) or higher. This temperature cannot be reached in the exhaust system under all engine operating conditions.

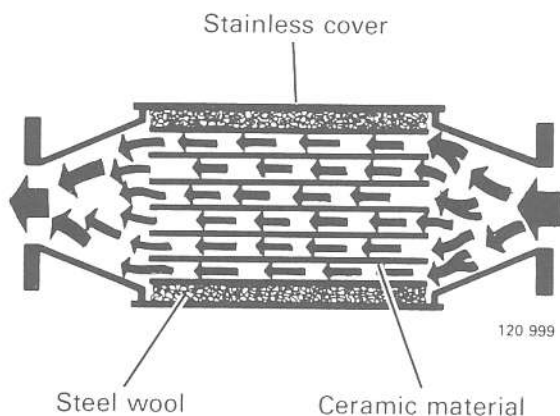

By means of the catalytic converter, this combustion can be achieved at temperatures as low as $300^{\circ}\text{C} = 575^{\circ}\text{F}$.

The most important substances used are platinum and palladium. These metals are evenly spread over a ceramic body with a cellular structure. The exhaust gases come into contact with these surfaces as they pass through the converter. The catalytic ceramic body is not in any way used-up during operation.

Three-Way (Oxidation & Reduction) Catalytic Converter

The purpose of the three-way catalytic converter is to oxidize carbon monoxide (CO), hydrocarbons (HC) and reduce oxides of nitrogen (NOx) in the exhaust gases. This is achieved by converting carbon monoxide and hydrocarbons to carbon dioxide and water, respectively. At the same time, oxides of nitrogen are converted to nitrogen and water. The operating range of the three-way catalytic converter is limited to a narrow band around the ideal air/fuel ratio for the engine. Within this band, the conversion of carbon monoxide, hydrocarbons and oxides of nitrogen can take place most efficiently.

The three-way catalytic converter accelerates the reaction of carbon monoxide, hydrocarbons and oxides of nitrogen at temperatures as low as $300^{\circ}\text{C} = 575^{\circ}\text{F}$.

Platinum and rhodium are the most important substances in this type of converter.

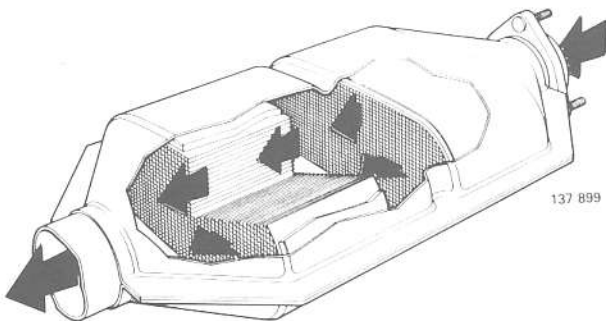

CRANKCASE EMISSION CONTROLS

General

The crankcase emission controls prevent crankcase gases from being released into the atmosphere. Instead, the crankcase gases are directed to the intake manifold. Crankcase gases are removed from the crankcase by positive crankcase ventilation (PCV). Engine vacuum draws the crankcase gases out, thus allowing fresh air to be drawn in.

Components

(Not all components appear on all models; designs may vary)

Positive Crankcase Ventilation (PCV) Valve

Regulates the flow through the PCV system. During periods of deceleration and idle, manifold vacuum is high. The high vacuum causes the PCV valve to restrict the air flow. During acceleration or constant speed operation manifold vacuum is low. The lower vacuum allows the PCV valve to open fully.

Flame Guard

Prevents a possible backfire from entering the crankcase. Should the backfire enter the crankcase, it could ignite the blow-by gases. Periodic cleaning of the flame guard helps prevent crankcase over-pressure.

Nipple

Regulates the crankcase gas flow and ensures that crankcase vacuum does not become excessive.

Oil Trap

Separates oil from gases and thus reduces oil consumption and emissions. An additional benefit is more effective control of the vacuum in the crankcase.

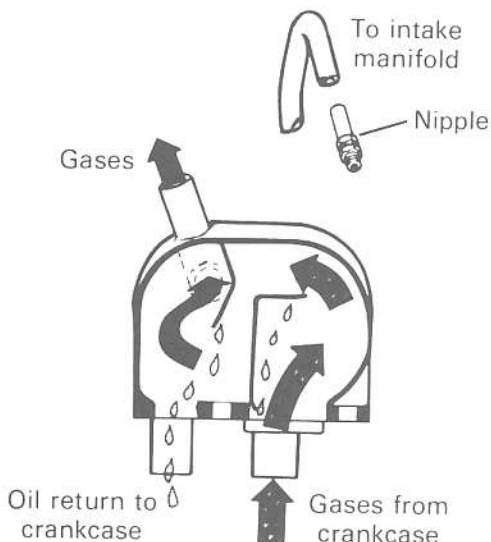
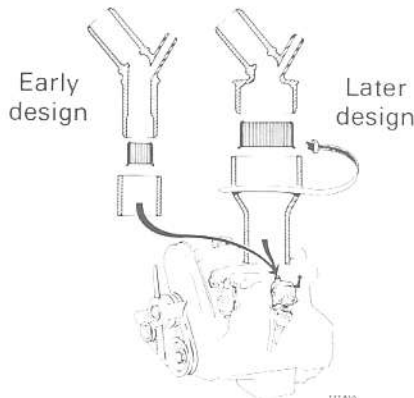
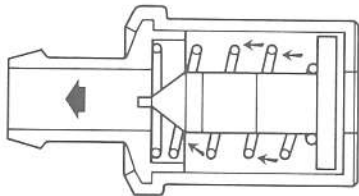
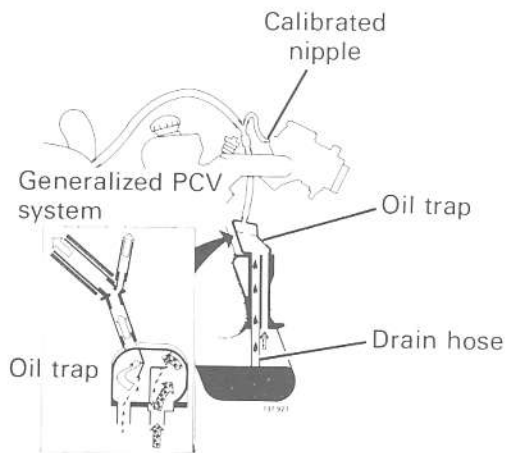

CRANKCASE EMISSION CONTROL, COMPONENT PLACEMENT

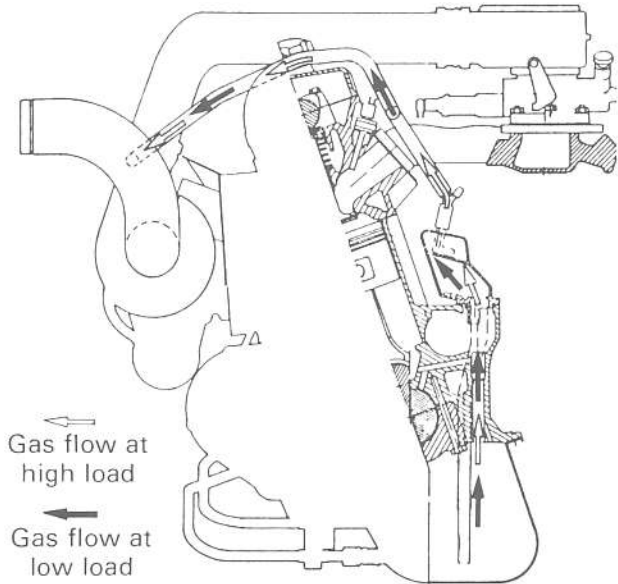

B21F-Turbo

Crankcase ventilation gases are routed to a point in front of the turbo charger. Vacuum is always present when the engine is running and no additional connection with the intake manifold is necessary.

There is no flame guard at the oil trap.

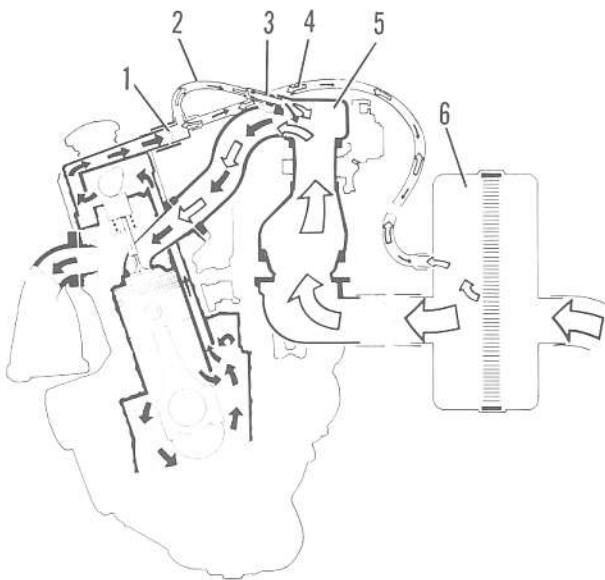

B21F (Non-Turbo)

1. Flame guard.
2. Hose, channeling crankcase fumes to the intake manifold.
3. Nipple with orifice.
4. Hose, channeling:
 - fresh air from the air cleaner to the crankcase (idle)
 - or crankcase fumes to the air cleaner (cruising speeds)
5. Intake manifold.
6. Air cleaner.

-Crankcase Emission Controls-

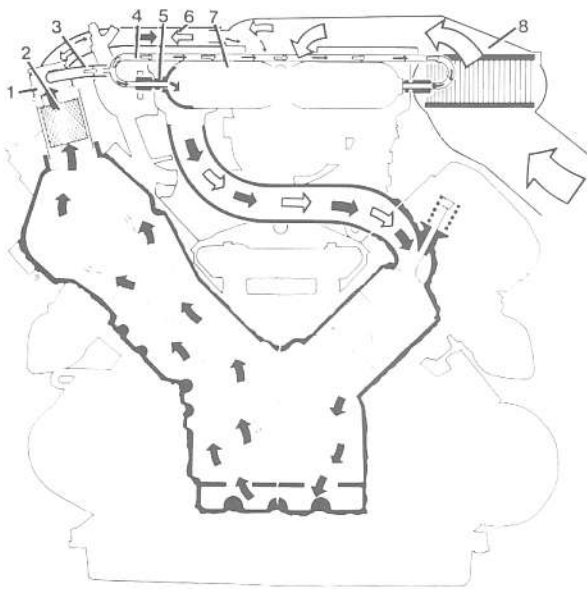

B27F, B28F

1. Oil trap.
2. Flame guard.
3. Hose, channeling crankcase fumes to the intake manifold.
4. Distributor pipe.
5. Nipple with orifice.
6. Hose, channeling:
 - fresh air from the air cleaner to the crankcase (idle)
 - crankcase fumes to the air cleaner (cruising speeds)
7. Intake manifold.
8. Air cleaner.

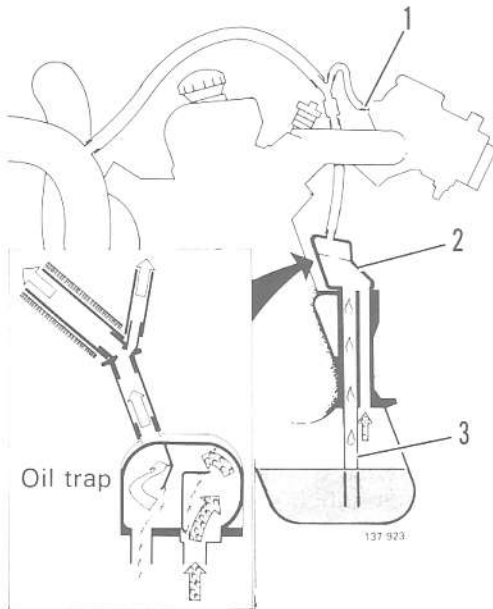

B21F-Turbo

Oil is separated from the crankcase gases by an oil trap shown in the illustration. It is connected to the inlet system before the turbocharger, and to the intake manifold.

Depending on engine load, crankcase gases are conducted along different circuits.

A calibrated nipple in the intake manifold regulates the gas flow and ensures that crankcase vacuum does not become excessive.

1. Calibrated nipple
2. Oil trap
3. Drain hose



B23F, B230F

1. PCV nipple
2. Flame guard
3. Oil trap

EVAPORATIVE CONTROL SYSTEM

General

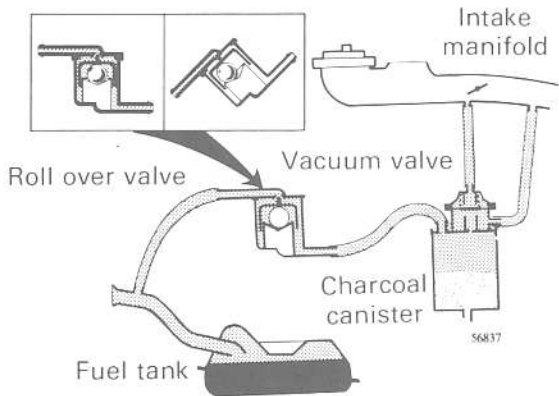

System prevents gasoline fumes (i.e. vapors) from being released into the atmosphere. Fumes from the fuel tank are channeled to the evaporative control canister. Carbon in the canister stores the gasoline fumes until the engine is started. With the engine running the gasoline fumes are drawn into the fuel induction system.

Components

(Not all components appear on all models; designs may vary)

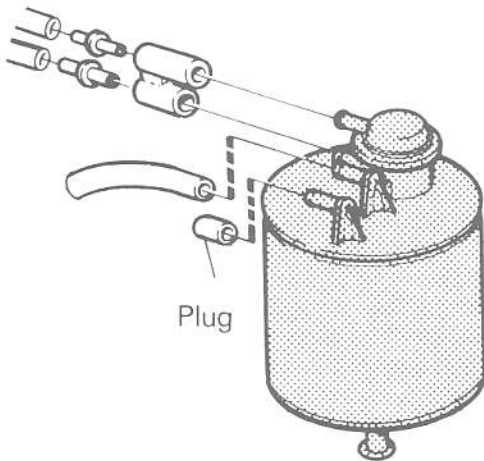

Evaporative Control Canister (Carbon Filter)

Canister contains active carbon which absorbs gasoline fumes. The use of alcohol or alcohol-gasoline fuels will reduce the effectiveness of the charcoal in the canister.

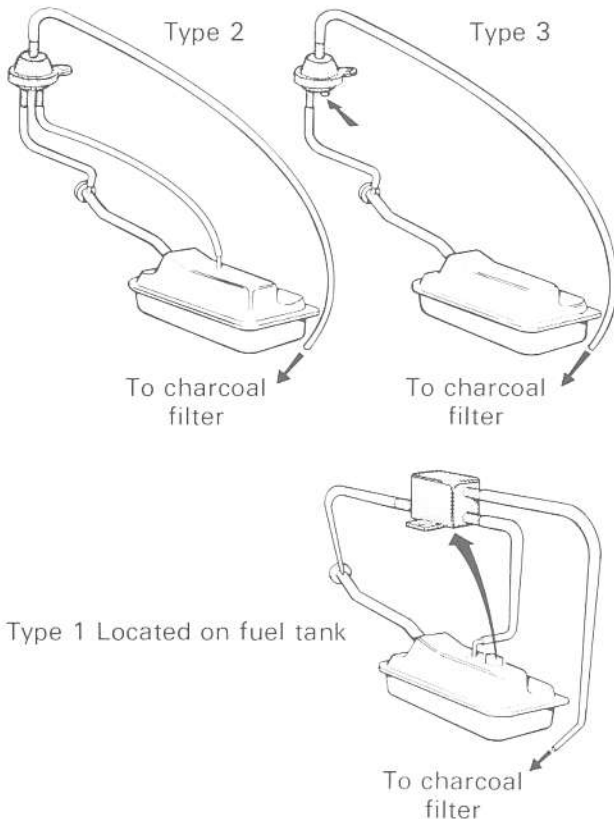

Balance Valve (Equalization Valve)

Controls the connection between fuel tank and evaporative control canister. Balance valve incorporates both over-pressure and under-pressure valves. This valve was discontinued in 1980 and was replaced with tank relief valves incorporated into the fuel filler cap.

-Evaporative Controls-

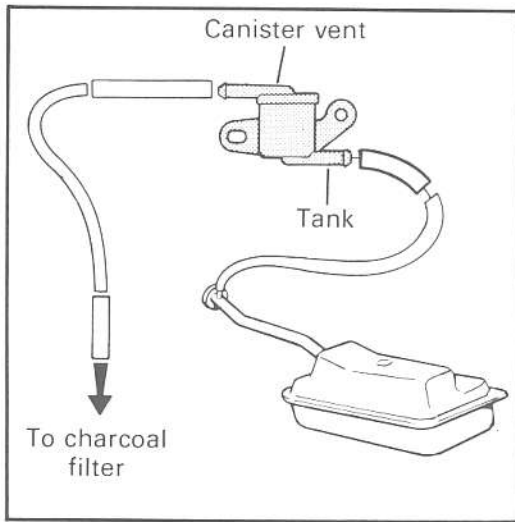

Roll-over Valve

Valve closes when vehicle is inclined to one side more than 45°. This prevents fuel leakage via the evaporative system hose in the event of a collision.

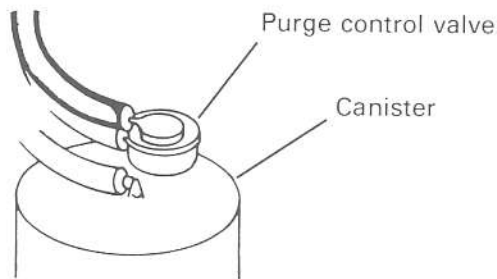

Air Valve (Purge Valve, Vent Valve)

Controls the connection between evaporative control canister and intake manifold. Valve closes when engine is not running, thus preventing the escape of gasoline fumes from the canister. A purge control vacuum signal is taken ahead of the throttle plate in the closed position. At engine idle a small purge flow occurs through the constant purge hole in the canister valve. When the throttle is opened, the vacuum to the purge control allows full canister purge at a controlled rate.

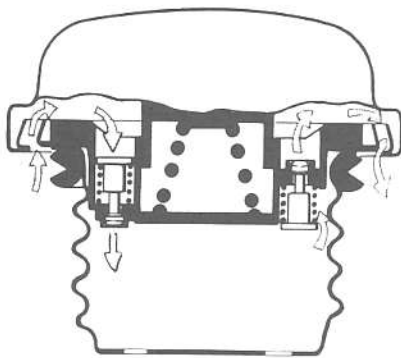

Tank Relief Valves

Located in the fuel filler cap. Two safety valves prevent damage to the fuel system in the event of damage or blockage to the vent system. One valve opens during periods of over-pressure, the other during periods of under-pressure.

EVAPORATIVE CONTROL SYSTEM, COMPONENT PLACEMENT

B27F (1976-1977)

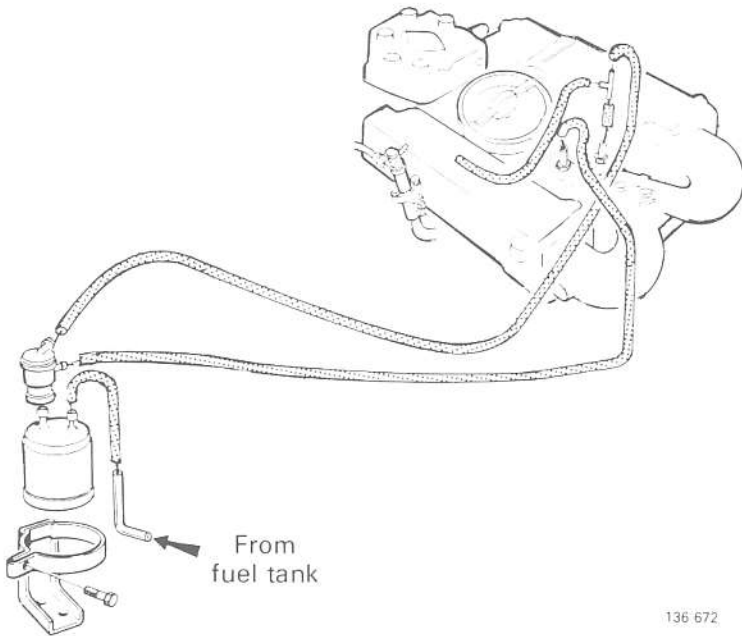

136 672

B27F (1978)

Vehicles with impulse relay

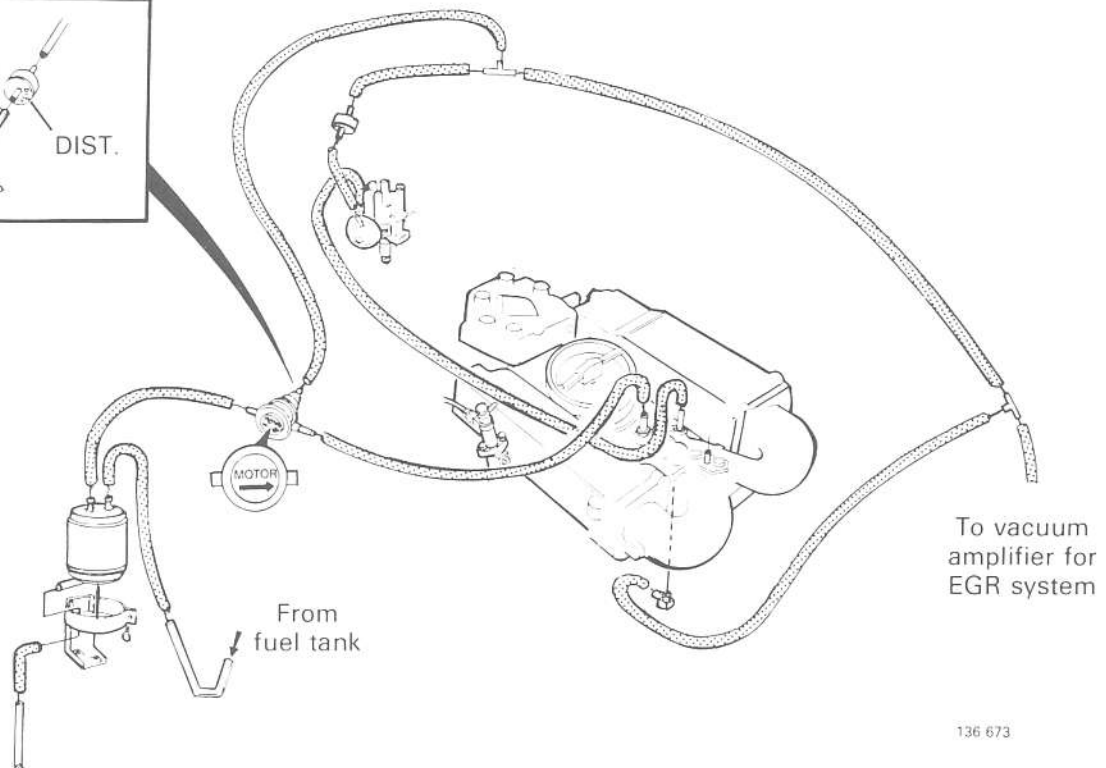

136 673

-Evaporative Controls-

B27F (1979)

Vehicles with impulse relay

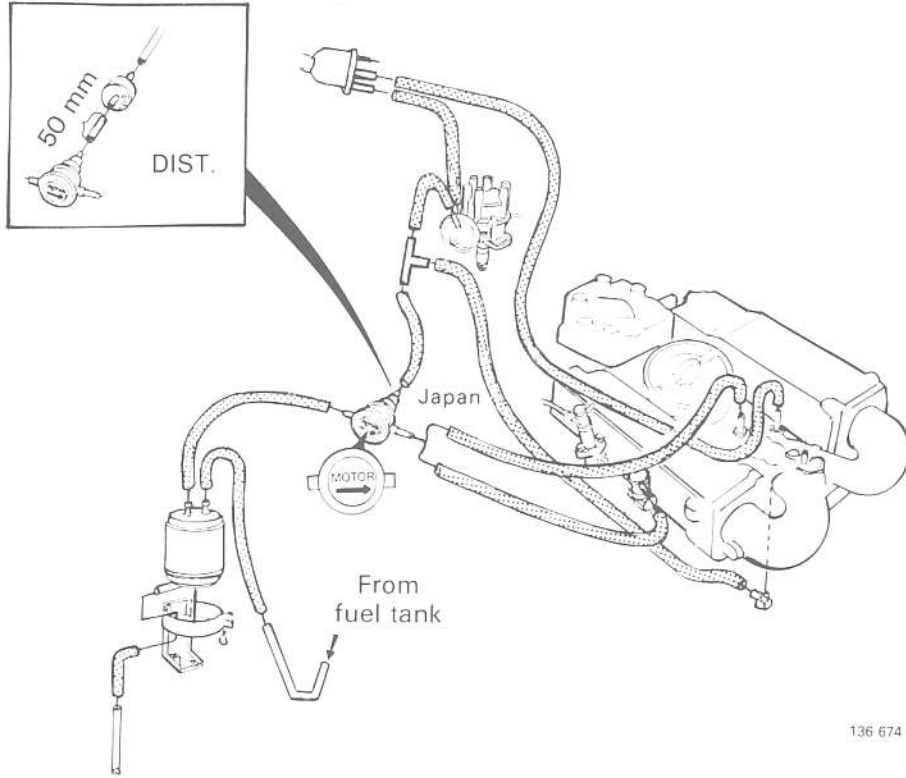

B28F (1980-1982)

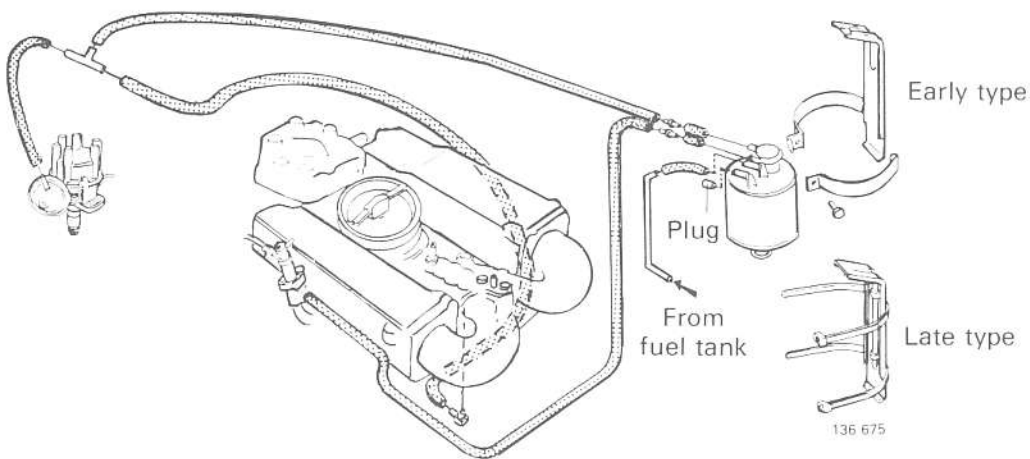

B21F (1976-1980)

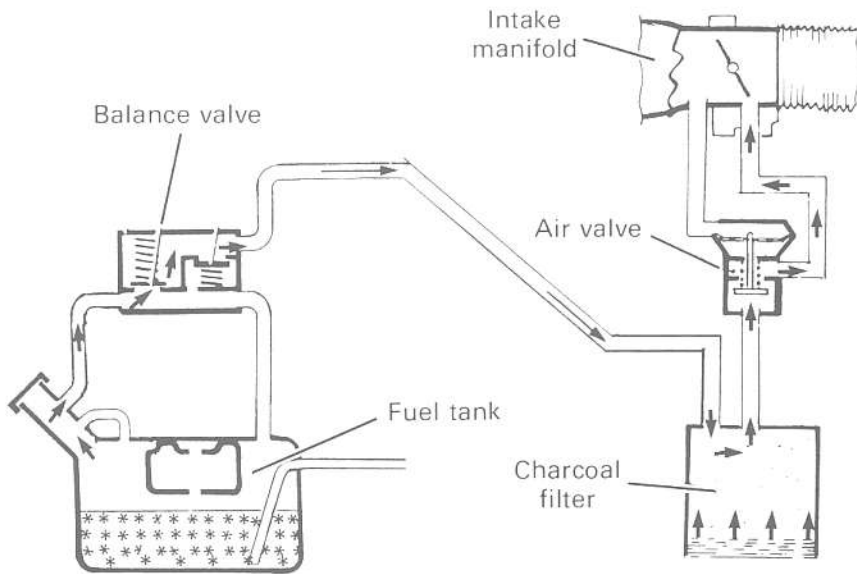

B21F-Turbo (1982-)

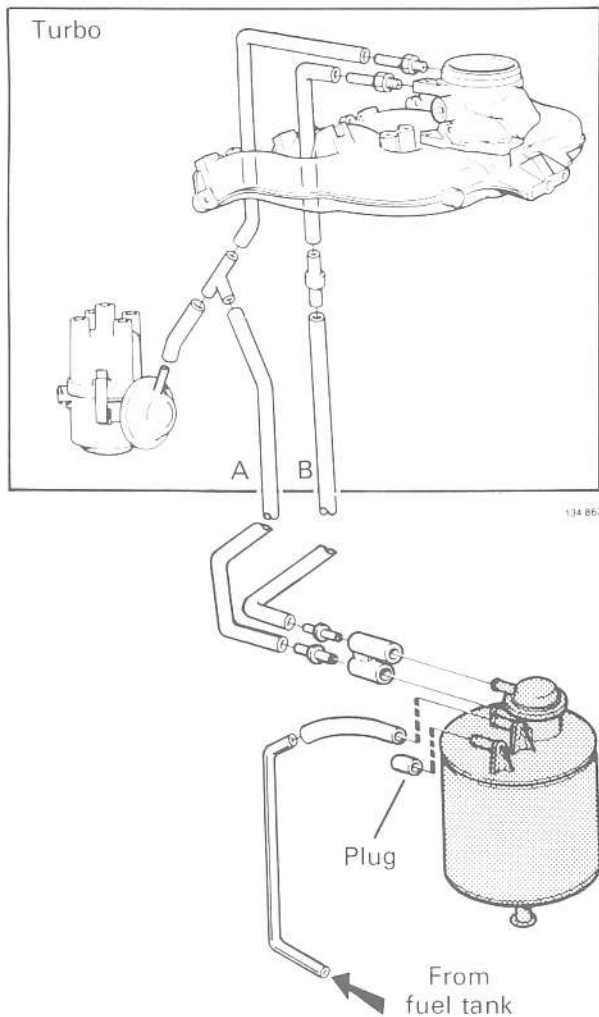

-Evaporative Controls-

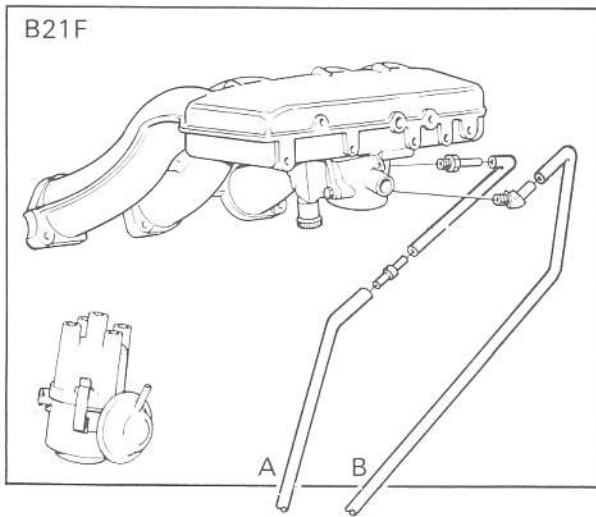

B21F (1981-1982)

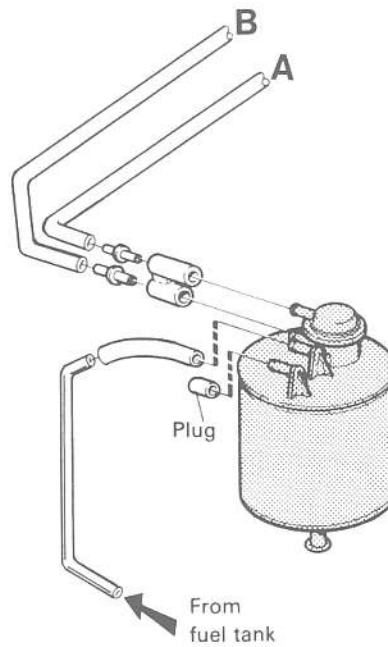

B23F (1983-)
B230F (1985-)

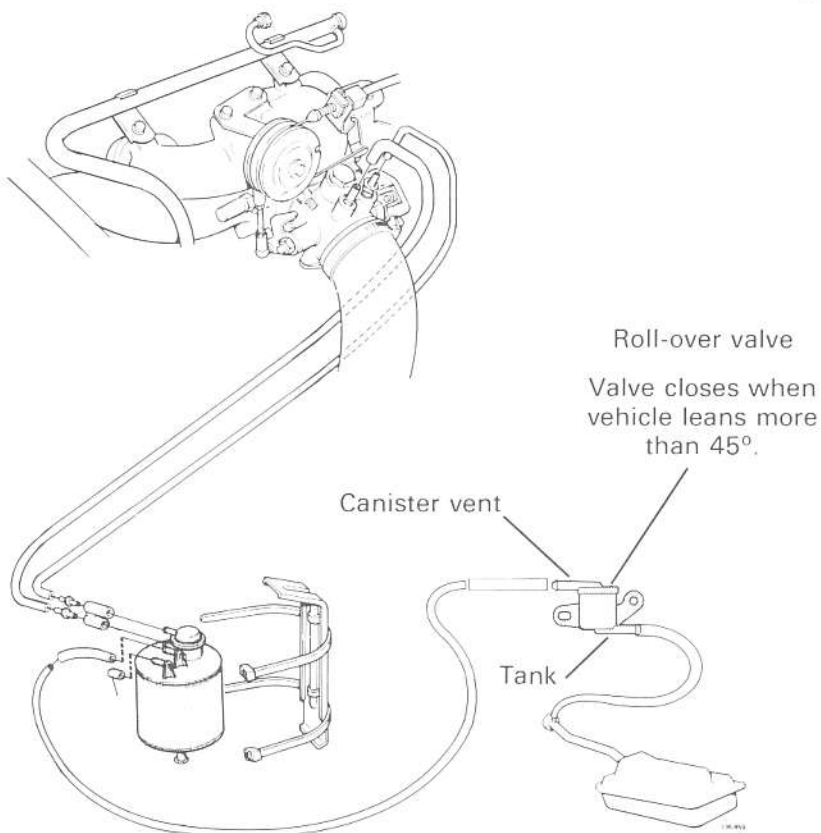

AIR PUMP SYSTEM

General

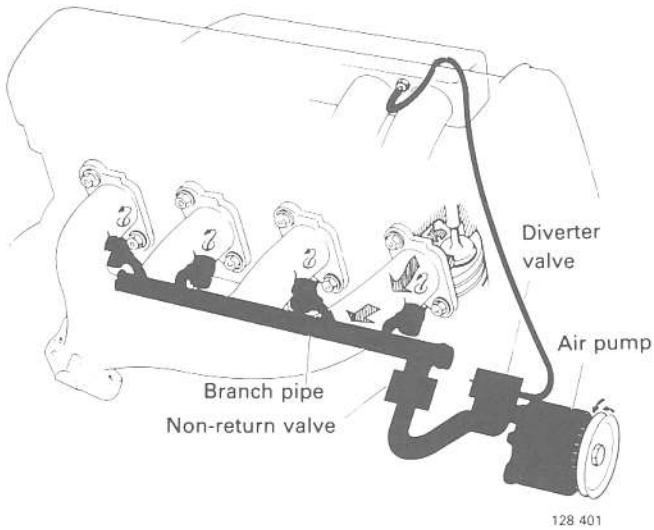

Admits fresh air to the hot exhaust gases in the exhaust manifold. The fresh air aids in oxidizing hydrocarbon. Air is drawn in through the air filter. The compressed air is fed out of the pump through the diverter valve.

Components (Designs may vary)

Air Pump
Compresses fresh air to be forced into the exhaust manifold.

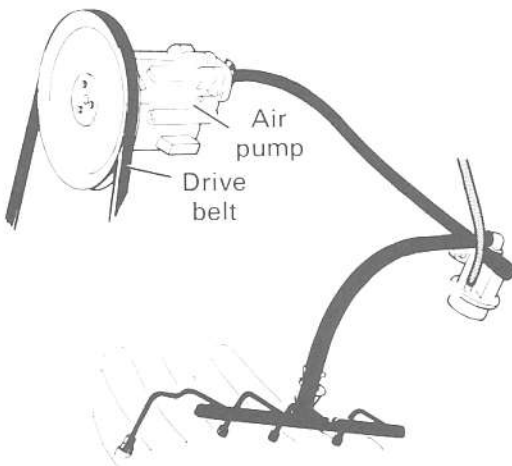

-Air Pump-

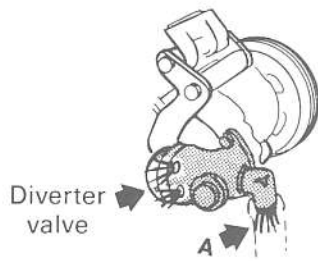

Diverter Valve

This valve has two functions. It regulates the air pump pressure. It also shuts off the air delivery when the engine vacuum is high. If the system was allowed to operate under this condition, fresh air mixed with the overly-rich exhaust gas vapors would cause a backfire.

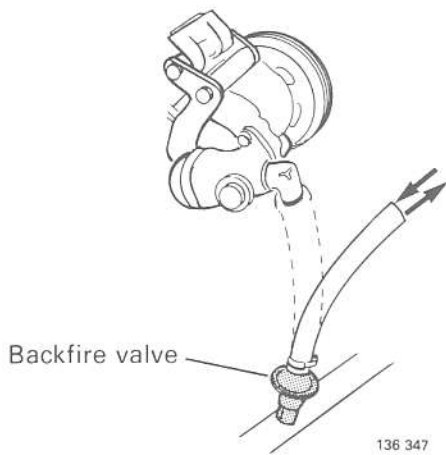

Backfire Valve

The backfire valve admits air into the exhaust manifold but prevents return of exhaust gas to the air pump so that, in the event of a backfire or air pump malfunction, damage to the pump and/or the drive belt will not result.

AIR PUMP SYSTEM COMPONENT PLACEMENT

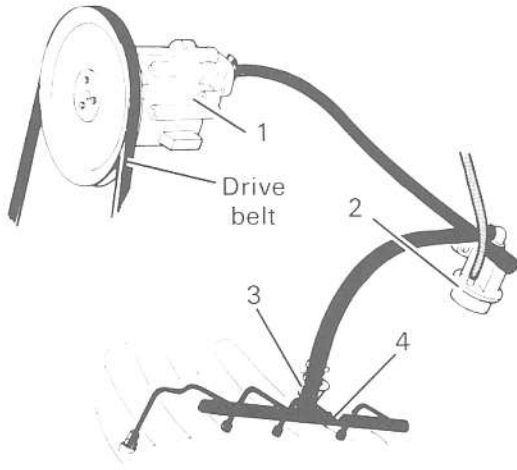

B21F (1976-1977)

- 1. Air pump
- 2. Diverter valve
- 3. Backfire valve
- 4. Air manifold

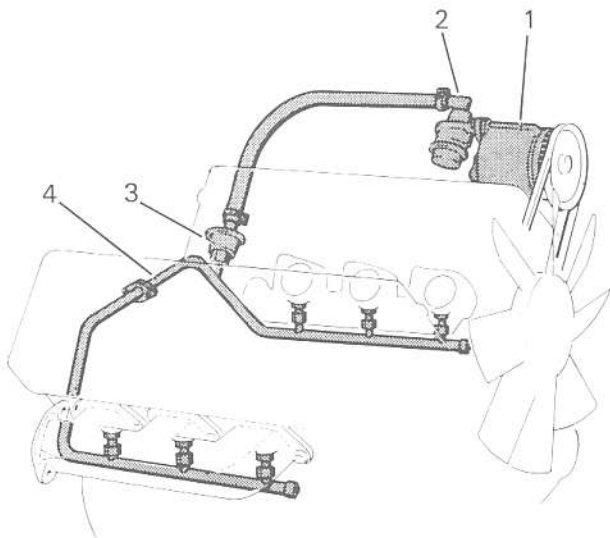

B27F (1976-1977)

- 1. Air pump
- 2. Diverter valve
- 3. Backfire valve
- 4. Air manifold

ALTITUDE-COMPENSATING CONTROL PRESSURE REGULATOR

General

Regulator automatically adjusts the fuel injection pressure for different altitudes. The regulator decreases the injection pressure at higher altitudes to automatically adjust for the lower air density. This maintains the correct air/fuel mixture and ensures the lowest possible emissions.

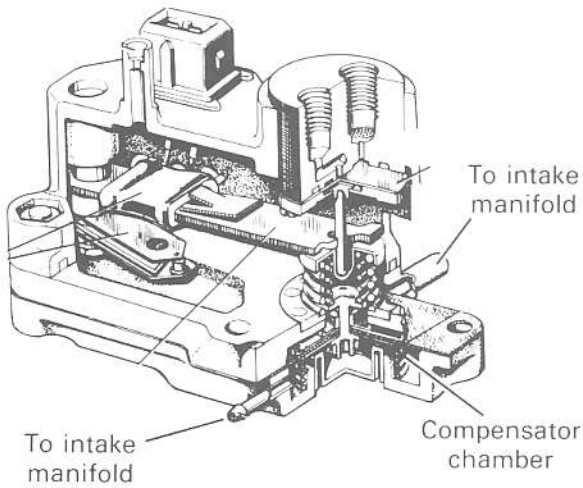

129075

Component

Control Pressure Regulator Incorporating Altitude-Compensating Device

The amount of fuel which the engine can burn depends on the amount of oxygen supplied in the air with the fuel. At high altitudes the air density (and, therefore, the amount of oxygen) decreases, for a given volume of air. The fuel supply must also be decreased in the same proportion. The control pressure regulator is affected by atmospheric pressure. At high altitudes the pressure acting on the diaphragm in the regulator is less than at low altitudes, and the diaphragm consequently takes up a slightly lower position. This increases the spring force and the regulator closes slightly which results in an increase in control pressure, i.e. a correct fuel/air mixture.

NOTE

The control pressure regulator is also controlled by temperature. This allows for a richer fuel/air mixture when the engine has not reached the normal operating temperature.

Atmospheric pressure

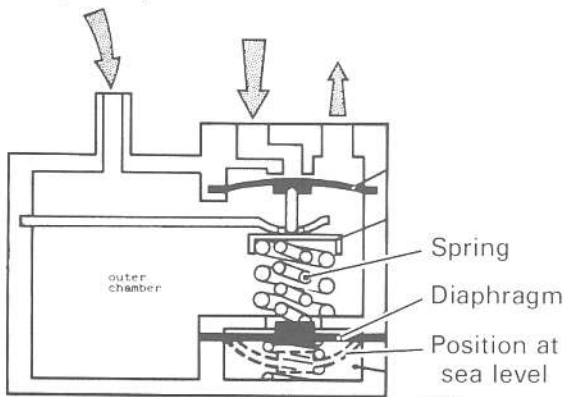

133F3F

ALTITUDE COMPENSATING REGULATOR, COMPONENT PLACEMENT

B21F (1976-1977)

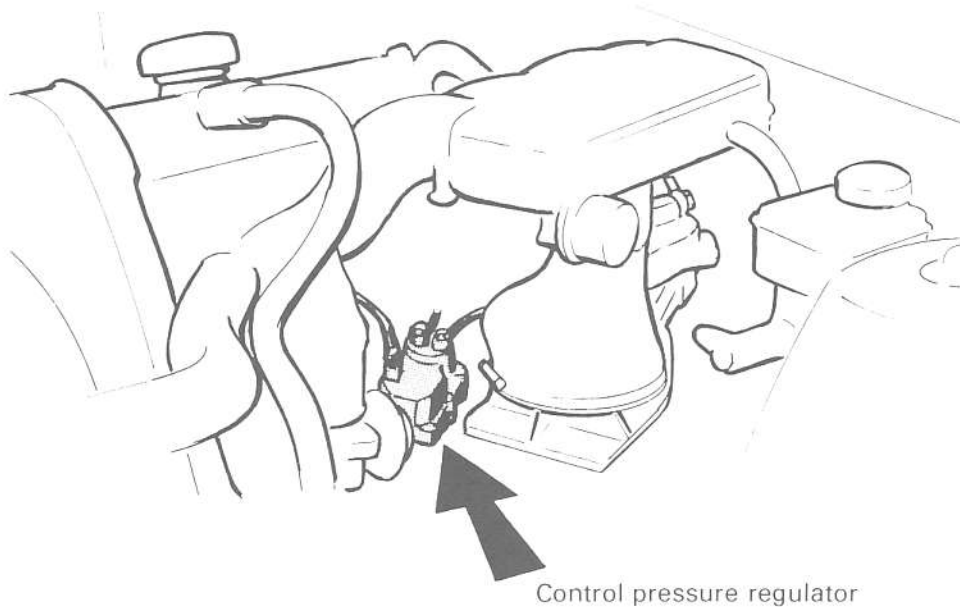

B27F (1976-1977)

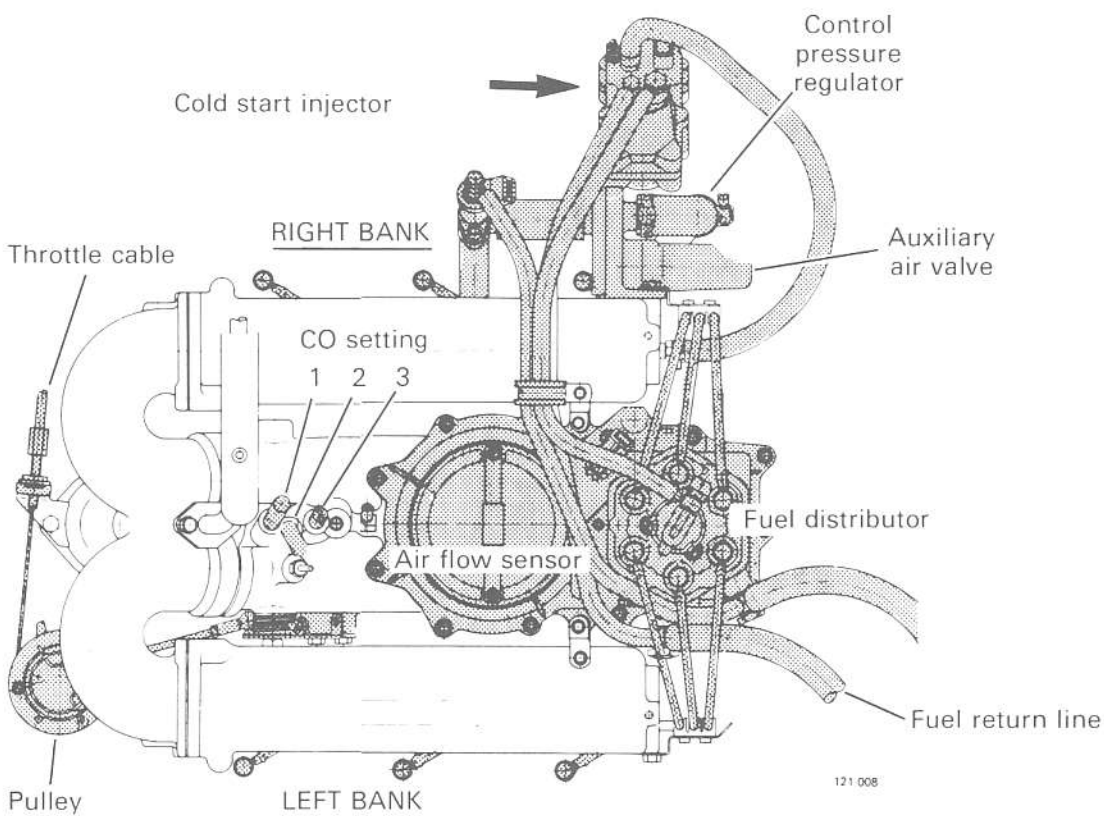

EXHAUST GAS RECIRCULATION

General

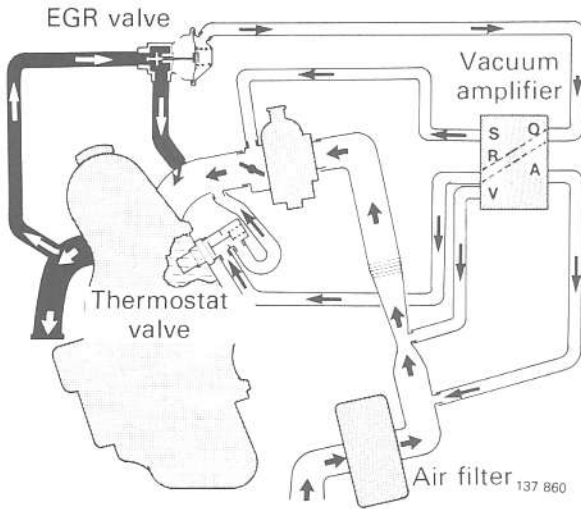

The Exhaust Gas Recirculation (EGR) system is used to reduce oxides of nitrogen (NO_x) emitted from the engine exhaust. Formation of NO_x takes place at very high temperatures; consequently, it occurs during the peak temperature period of the combustion process. To reduce and control NO_x formation, only a slight reduction in peak temperature is required. This reduction can be accomplished by introducing small amounts of an inert gas into the combustion process. If too much inert gas is allowed in (i.e. stuck EGR valve) the engine will idle roughly or not at all. The end products of combustion provide a continuous supply of relatively inert gases, therefore, it becomes a matter of recirculating those gases in the correct proportion.

To tap this continuous supply of inert gases, a connection is made between the exhaust and inlet manifolds.

There are two basic types of EGR systems, the ON-OFF type and the proportional EGR system.

Components

(Not all components appear on all models; designs may vary)

EGR Valve

A vacuum activated shut-off and metering valve. Controls the flow of exhaust gases from the exhaust manifold to the inlet manifold. Engine vacuum at the EGR valve causes the valve to open.

Thermostat

Allows vacuum to the EGR valve only when the engine is warm. This wax-type thermostat blocks system vacuum until the engine coolant temperature reaches 60°C = 140°F.

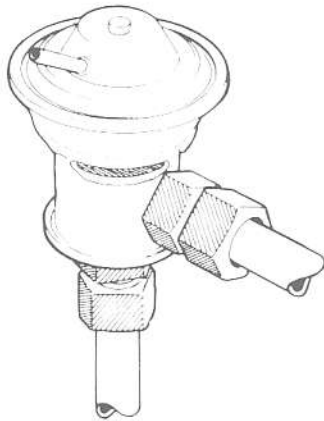

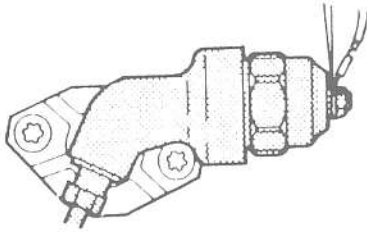

Solenoid Valve

Controls the vacuum to the EGR valve. Solenoid is actuated by a microswitch.

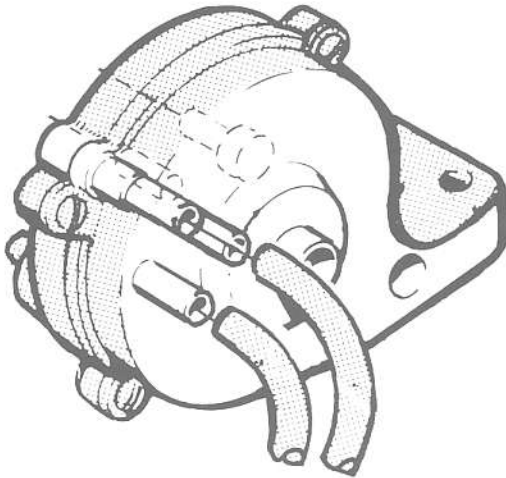

Vacuum Amplifier

Amplifies low intake vacuum. The vacuum amplifier receives vacuum from both the strong intake manifold source, and from the weak intake vacuum which is to be amplified.

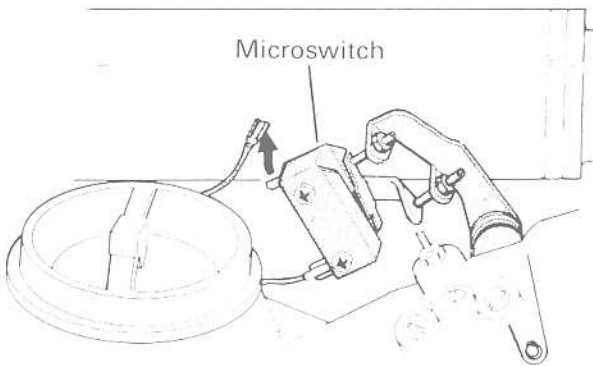

Microswitch

Used to activate the solenoid valve which controls the EGR valve. By precisely sensing the throttle-plate angle, the switch is able to shut-off vacuum to the EGR valve at idle and full-throttle.

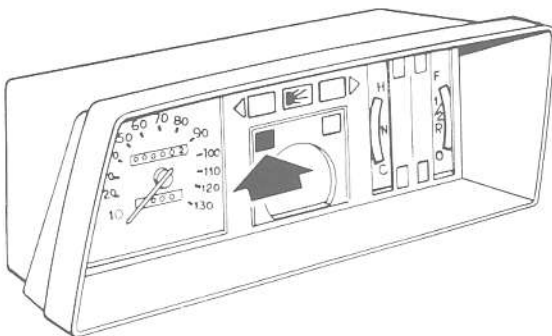

EGR Reminder Light

A reminder that the EGR system needs inspection. Light comes on automatically at 15,000-mile (25,000-km) intervals regardless of the condition of the EGR system.

EGR SYSTEM, COMPONENT CONNECTIONS AND PLACEMENT

B21F (1976, except California models)

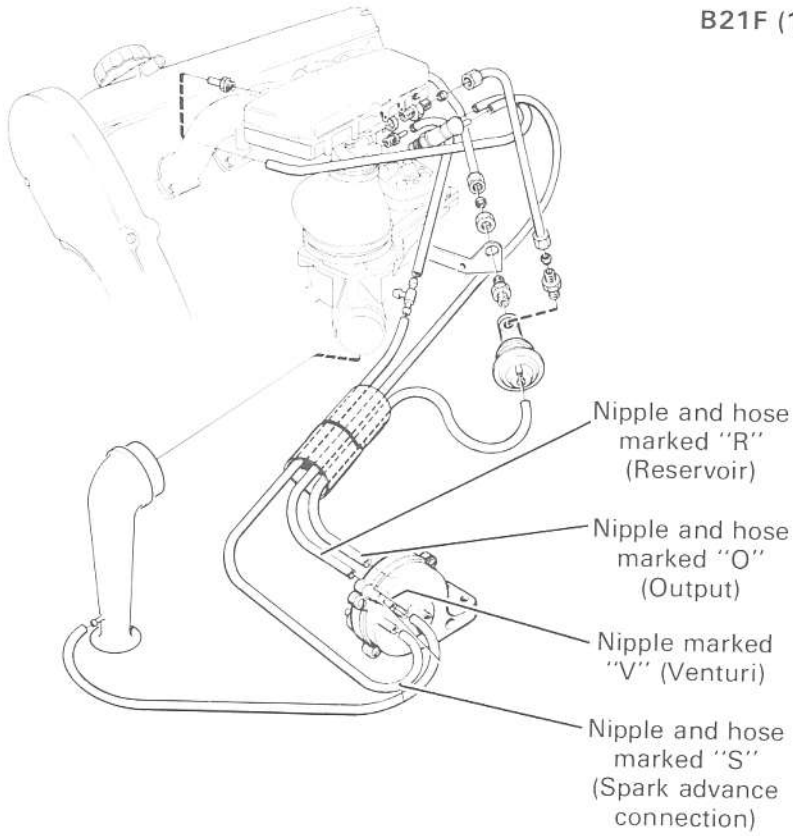

B21F (California 1976-1978)

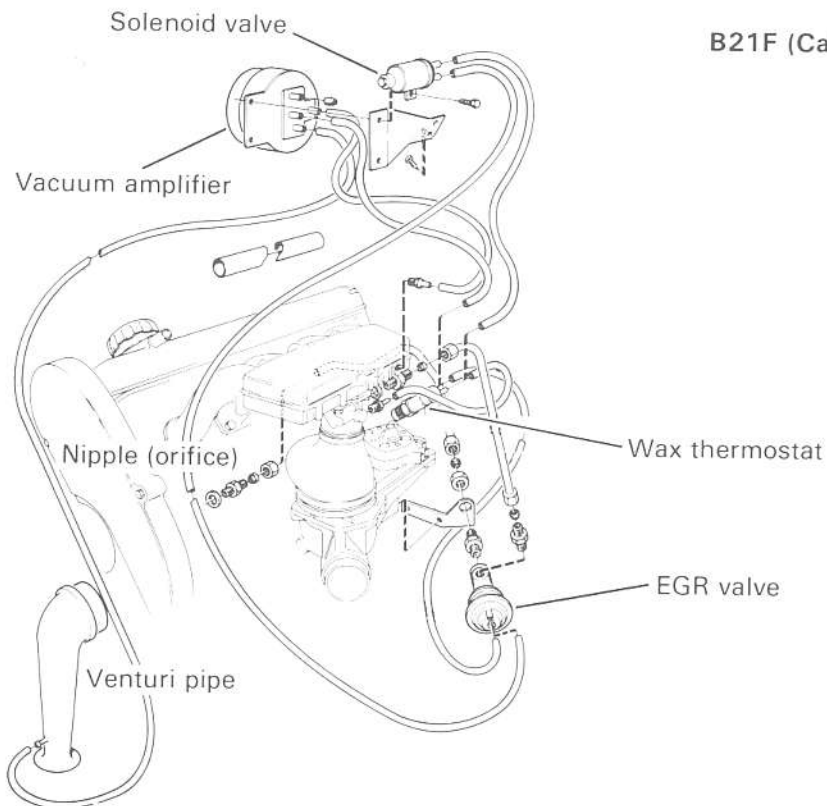

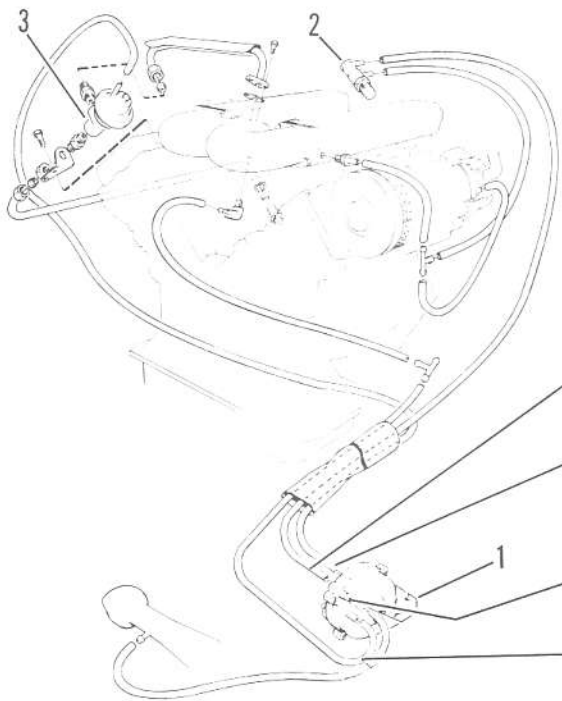

B27F (1976)

- 1. Vacuum amplifier
- 2. Thermostat
- 3. EGR valve

Nipple and hose marked "R" (Reservoir)

Nipple and hose marked "O" (Output)

Nipple marked "V" (Venturi)

Nipple and hose marked "S" (Spark advance connection)

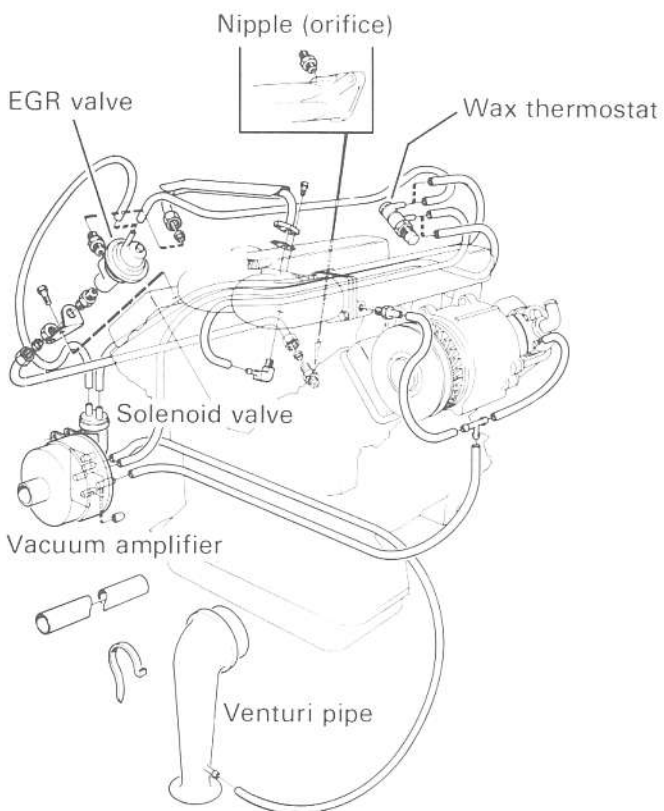

B27F (California 1976-1978)

PULSAIR SYSTEM

General

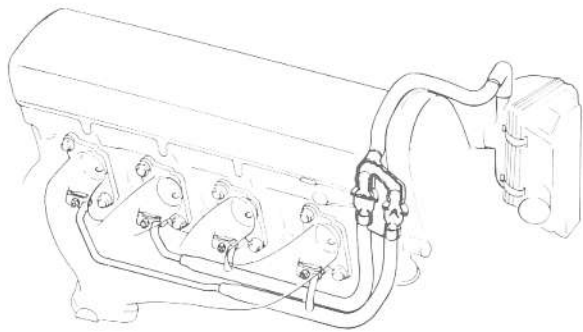

127 165

The “Pulsair” system replaced the air injection reactor (A.I.R.) on certain automobiles made for the Canadian market. When an engine is running there are pressure pulses in the exhaust manifold. These pressure pulses are followed by vacuum pulses. The “Pulsair” system allows air from the air cleaner to enter the exhaust manifold during these vacuum pulses.

Components

Check Valves

The check valves prevent exhaust gases from entering the air cleaner during the pressure pulses.

Piping

The piping distributes the air from the air cleaner to each exhaust outlet on the exhaust manifold.

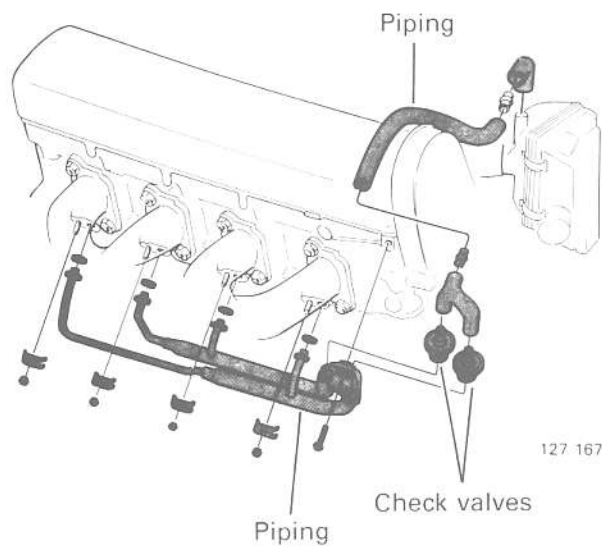

127 167

LAMBDA SOND SYSTEM

General

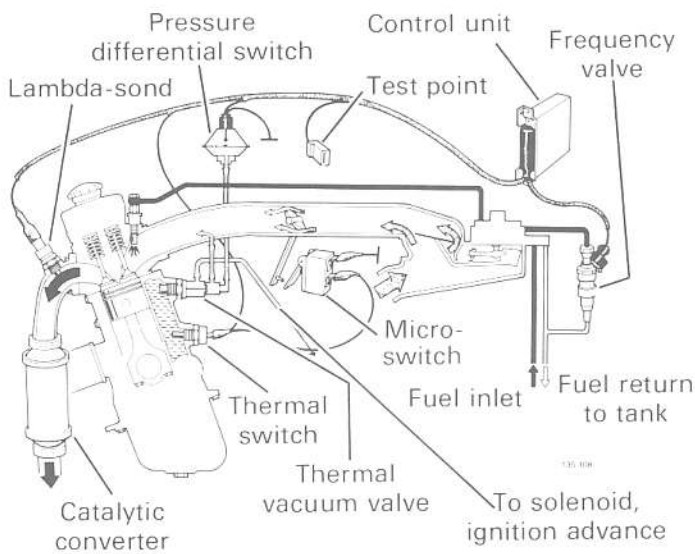

This is a self-adjusting engine control system designed to reduce emissions and improve fuel economy. An exhaust gas sensor, (oxygen sensor, also called Lambda sensor, or Lambda Sond) monitors the oxygen content of the exhaust gases leaving the engine. The exhaust gas analysis is fed into a closed loop feedback system. This continuously adjusts the air-fuel ratio to provide optimum conditions for combustion and efficient elimination of all three of the major pollutants (hydrocarbons, carbon monoxide and oxides of nitrogen) by a 3-way catalytic converter.

IMPORTANT!

Small amounts of lead are sufficient to damage the Lambda Sond. Unleaded gasoline must be used at all times.

Advantages:

- Allows nearly 100% combustion by the catalytic converter.
- Relatively clean exhaust gases.

$$\text{Lambda} = \frac{\text{actual air/fuel ratio}}{\text{optimum air/fuel ratio}}$$

Sond = Swedish for "sensor"

Components

(Not all components appear on all models; designs may vary)

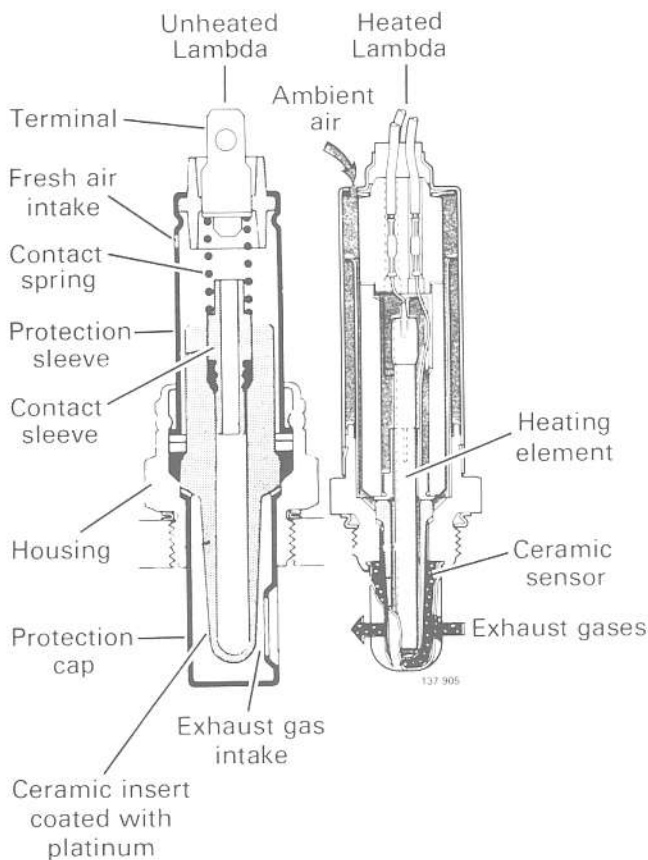

Lambda Sond (Oxygen Sensor)

Measurements are taken by a ceramic sensor in the Lambda Sond. It produces a small voltage (90-100 mV) in proportion to the difference between the oxygen content of the exhaust gas and the oxygen content of the ambient air. Exhaust gases heat up the sensor which begins to operate at 350°C = 660°F. In some models the oxygen sensor may not heat up quickly enough to the operating temperature of (350°C-660°F) due to lower exhaust gas temperatures. This means some Lambda Sonds are heated by an electric element. Heated Lambdas are found on the following engines: late 1984 B23F, and all B230F.

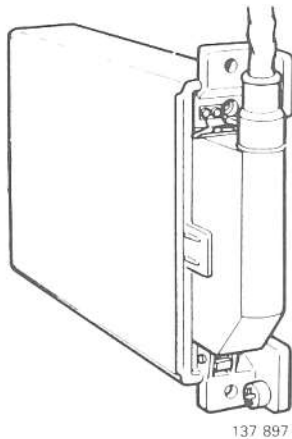

Fuel Injection

Control Unit

Monitors various sensors and controls:

- Engagement/disengagement of main relay (current supply to control unit, injectors, etc.)
- Fuel supply by varying injector open time.
- Idle speed by varying air control valve opening.

Control unit incorporates a micro computer.

The output from the oxygen sensor is fed into the control unit.

This device supplies a control current to the frequency valve. The control current has a set frequency and operates by varying the duty cycle.

When the oxygen sensor is cold, or defective, a "fixed control" program is engaged after approximately 5-10 seconds.

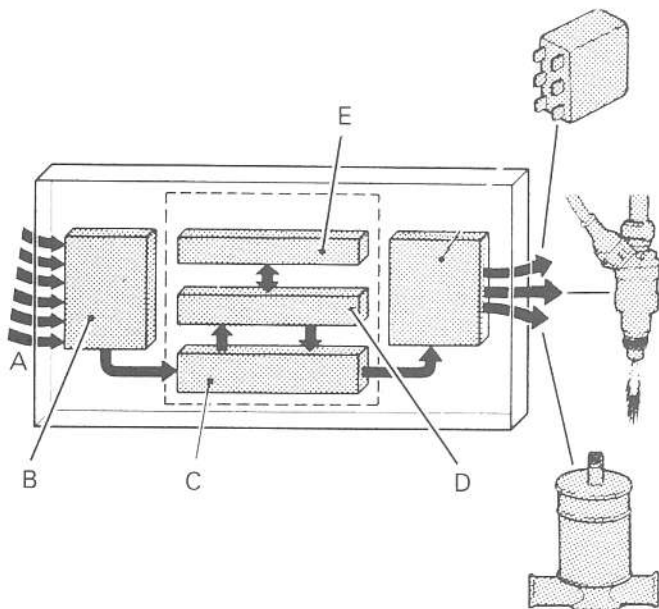

A Input signals from sensors

B Converter

Converts each signal into digital form which can be interpreted by computer.

C Input and output section

Controls information flow in computer.

D Micro-processor:

- compares air input and engine speed input to information stored in memory
- calculates amount of fuel to be injected
- adapts these values with regard to impulses from other sensors

E Memory

Contains precise information on appropriate fuel quantities and ignition timing for different air masses and engine speeds.

F Converter

Converts signals from micro-computer to voltages for control of system relay, injectors and air control valve.

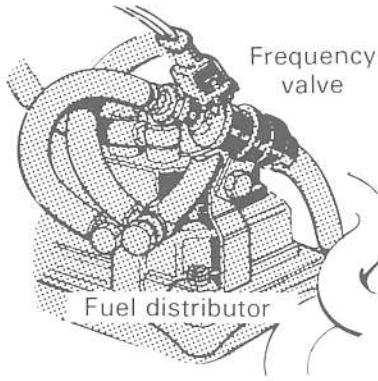

Frequency valve

This device influences the fuel flow by varying the pressure on the underside of the diaphragm in the pressure-regulating valves of the CI fuel injection system.

The frequency valve operates on a set frequency and by varying the ratio of closed to open times in the circuit.

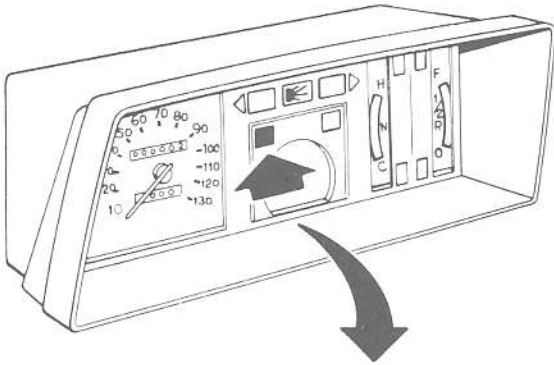

Reminder Light, Lambda Sensor

(Non-heated only)

Indicator light on the instrument panel which is activated at 30,000-mile (50,000-km) intervals. When light is activated, Lambda sensor should be replaced.

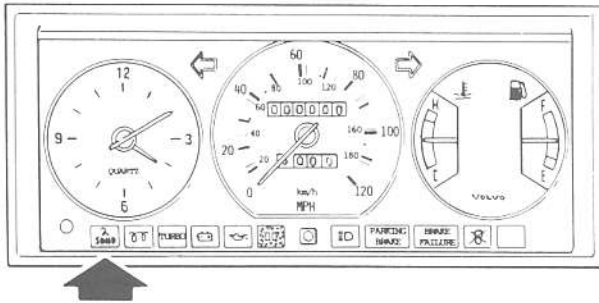

LAMBDA SOND COMPONENT PLACEMENT
240 series/1977

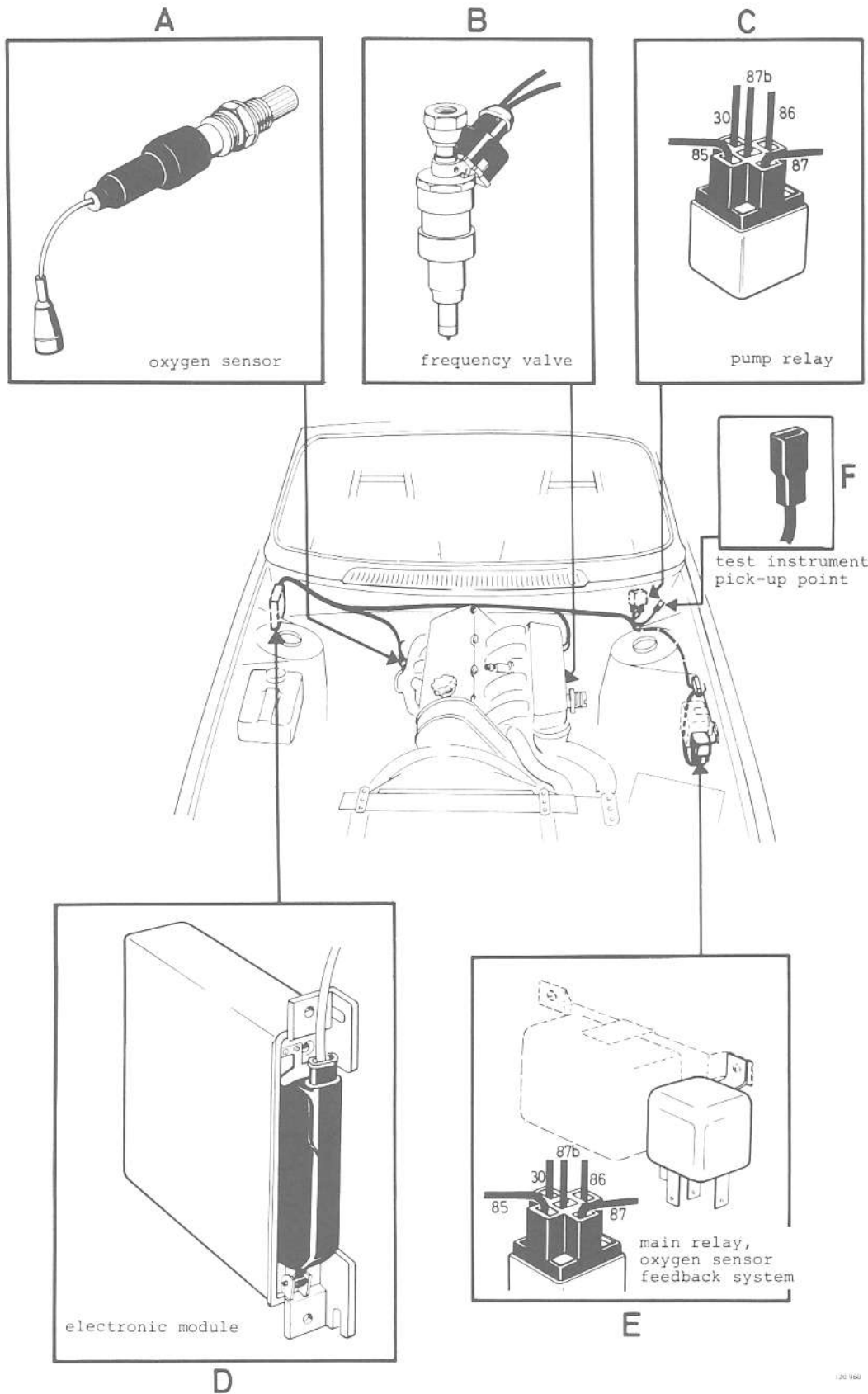

120 980

-Lambda Sond-

LAMBDA SOND WIRING DIAGRAM
240 series/1978

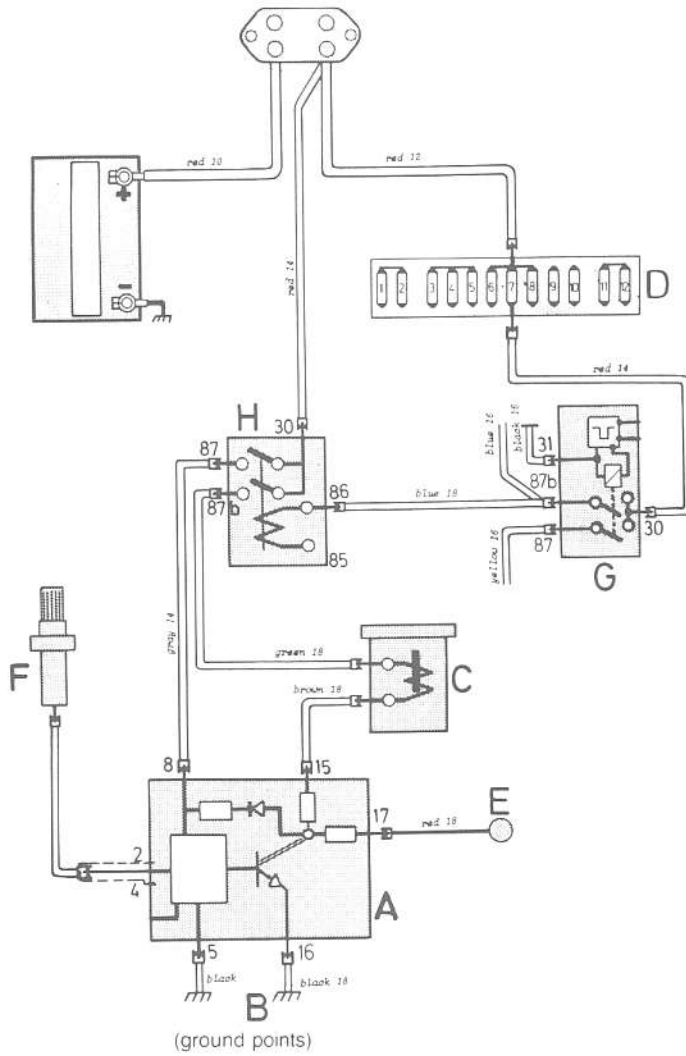

Fuse No. 7
Fuel pumps
Oxygen sensor system

- Legend:
- A Electronic module
 - B Ground points
 - C Frequency valve
 - D Fuse box
 - E Test instrument pick-up point
 - F Oxygen sensor
 - G Electronic pump relay
 - H System relay

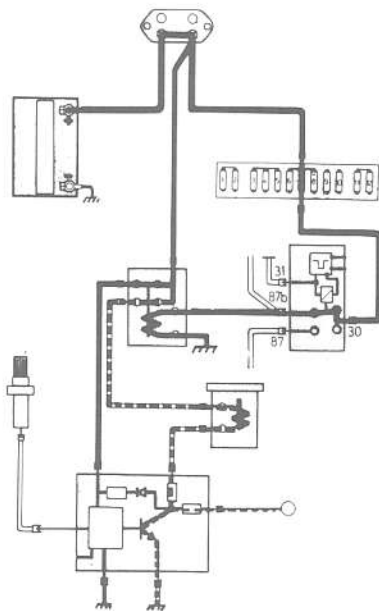

Frequency valve operating
Dotted line indicates
frequency valve current

LAMBDA SOND COMPONENT PLACEMENT
240 series/1978

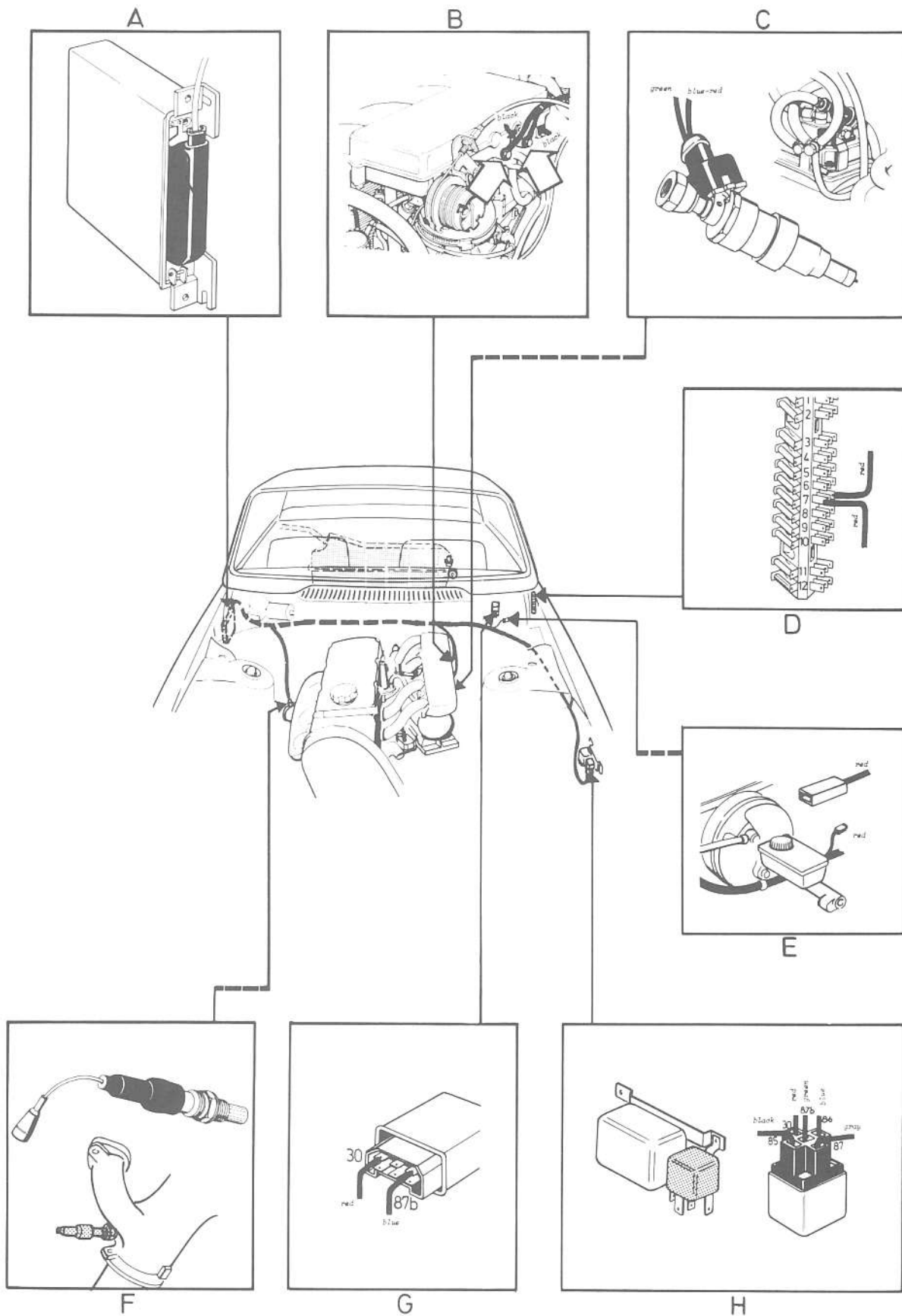

LAMBDA SOND WIRING DIAGRAM
260 series/1978

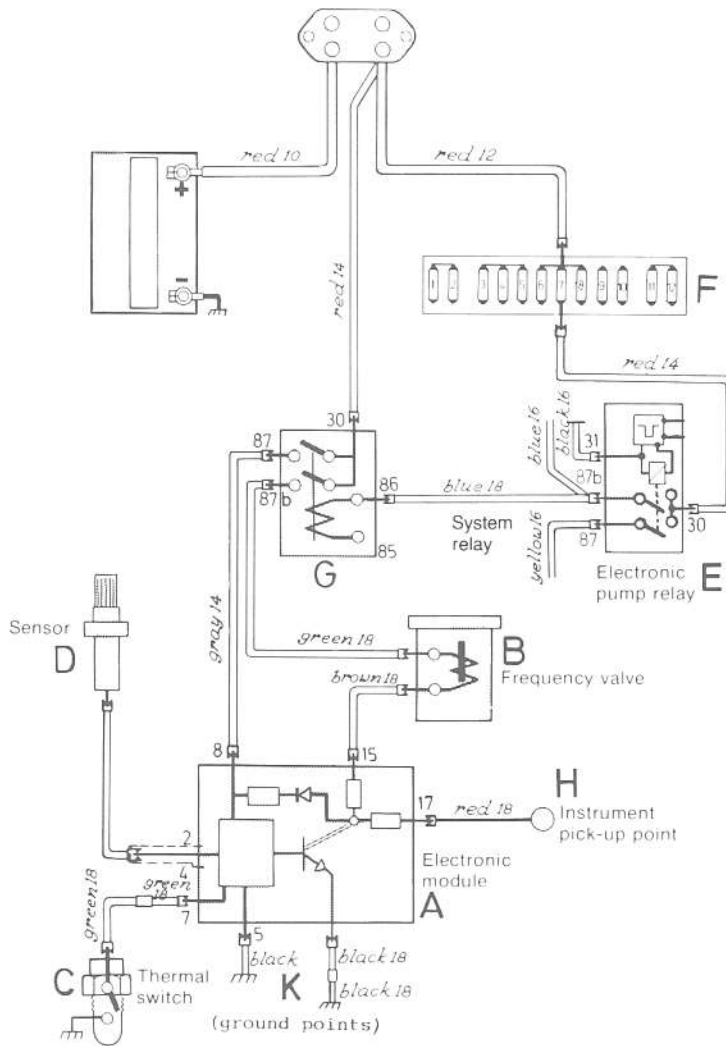

Fuse No. 7
Fuel Pumps
Oxygen sensor
system

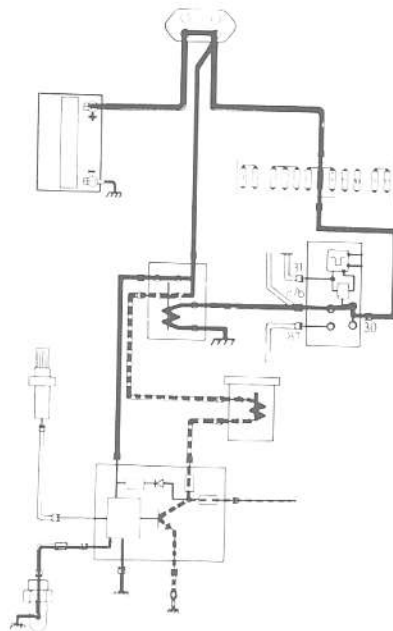

Frequency valve operating
Dotted line indicates
frequency valve current

LAMBDA SOND COMPONENT PLACEMENT 260 series/1978

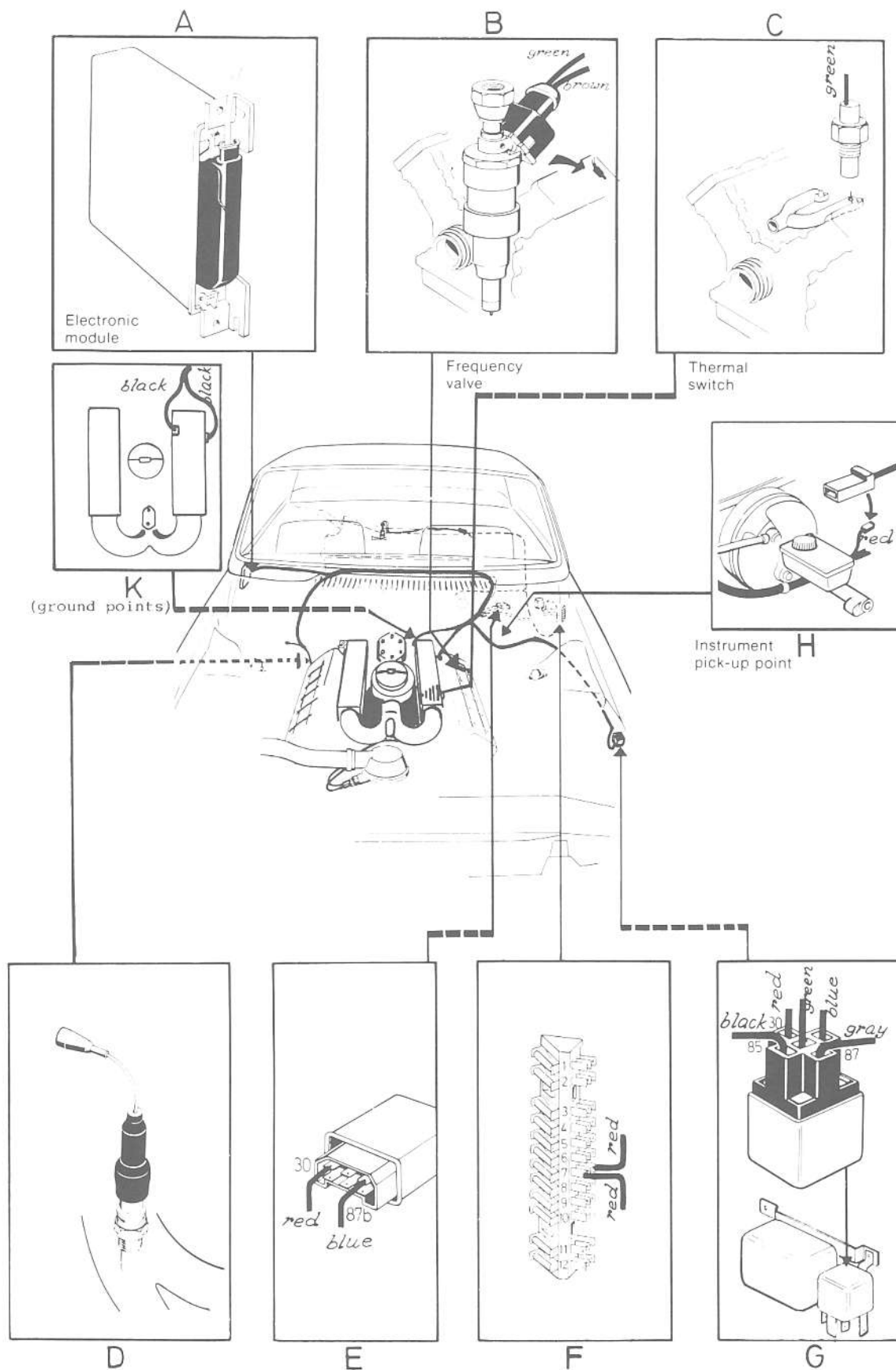

LAMBDA SOND WIRING DIAGRAM
240 series/1979

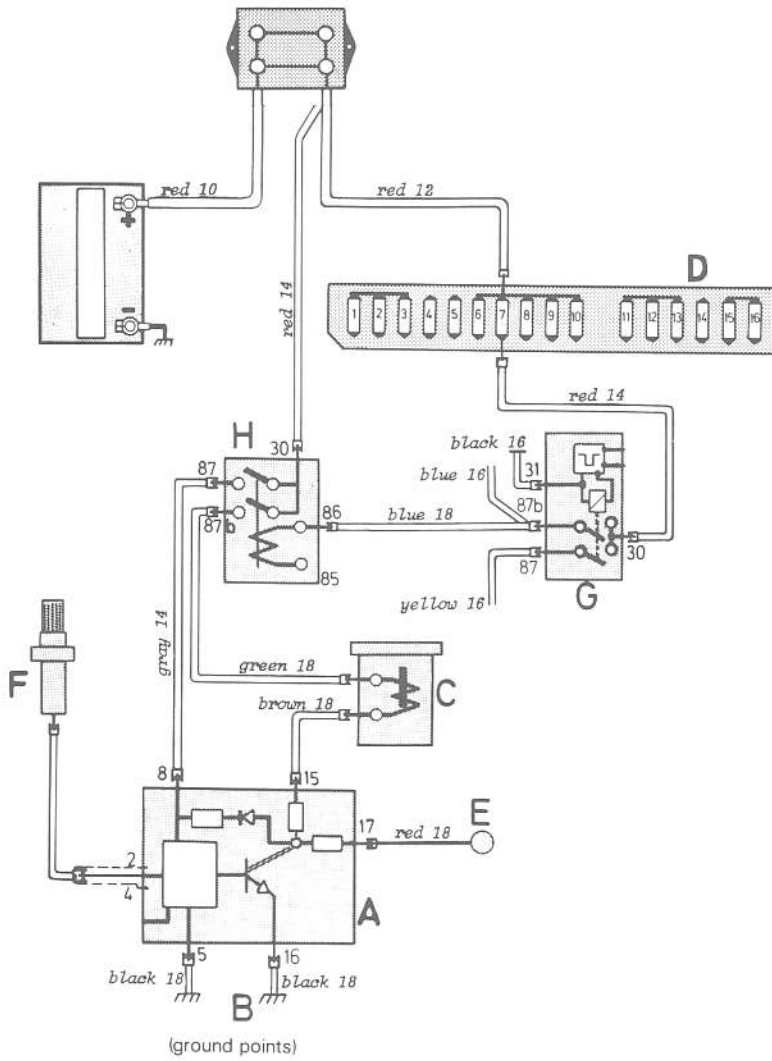

Fuse No. 7:
Fuel pump (main pump)

- Legend:**
- A Electronic module
 - B Ground points
 - C Frequency valve
 - D Fuse box
 - E Test instrument pick-up point
 - F Oxygen sensor
 - G Electronic pump relay
 - H System relay

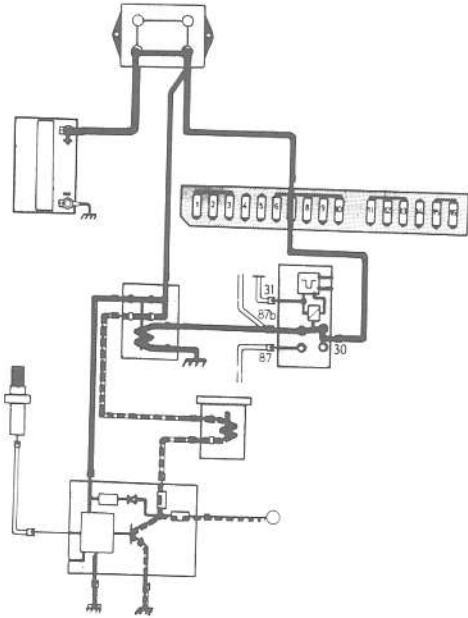

Frequency valve operating
Dotted line indicates
frequency valve current

LAMBDA SOND COMPONENT PLACEMENT
240 series/1979

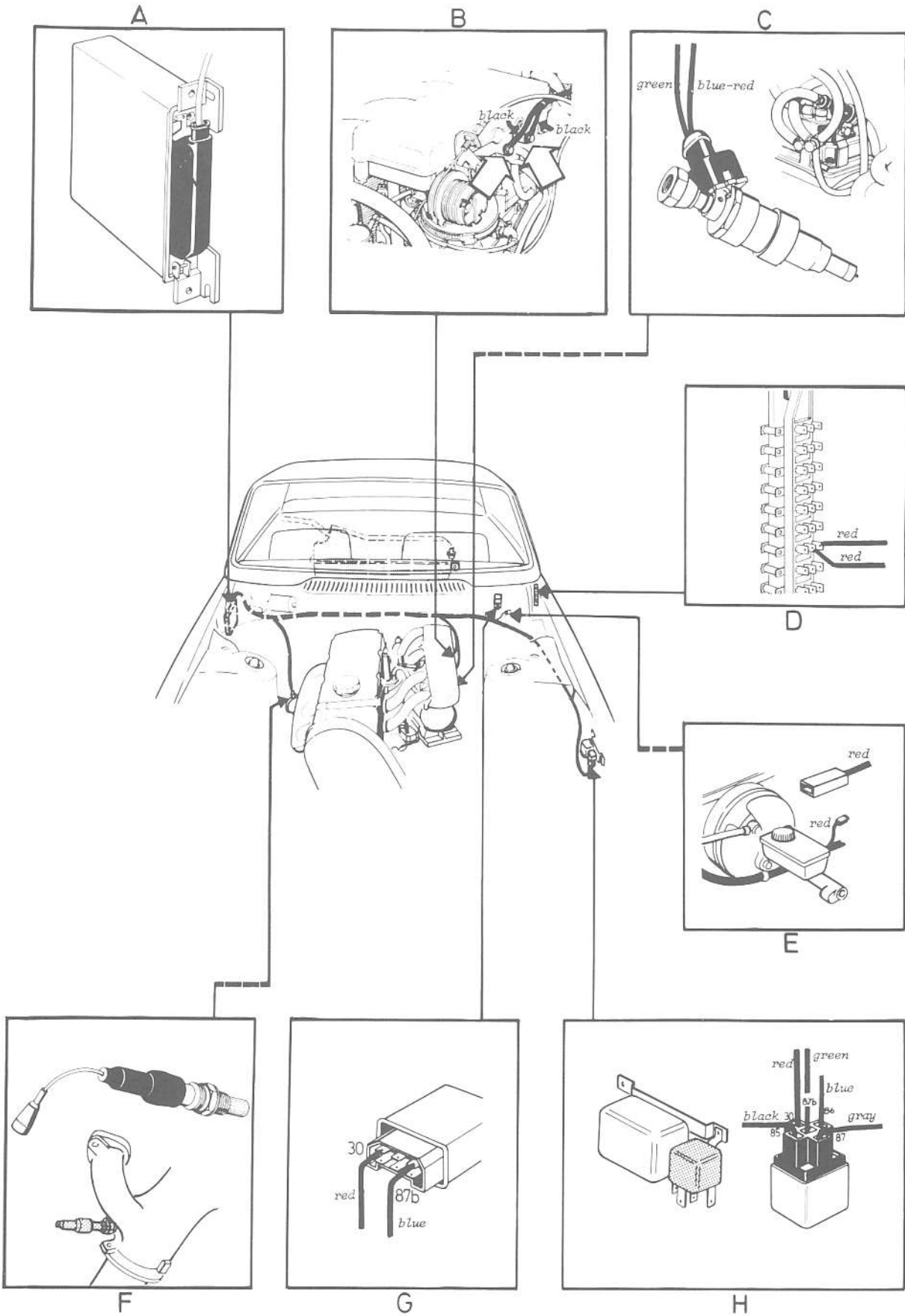

LAMBDA SOND WIRING DIAGRAM
260 series/1979

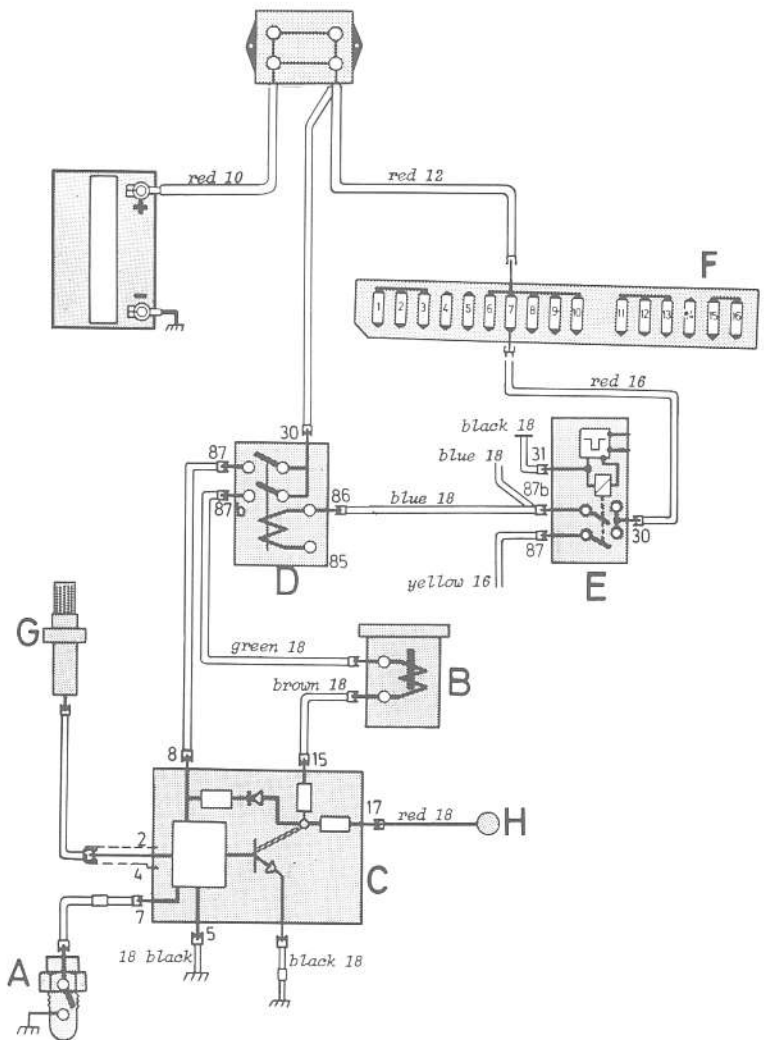

Fuse No. 7:

Fuel pump (main pump)

Legend:

- A Electronic module
- B Frequency valve
- C Thermal switch
- D Oxygen sensor
- E Electronic pump relay
- F Fuse box
- G System relay
- H Test instrument pick-up point

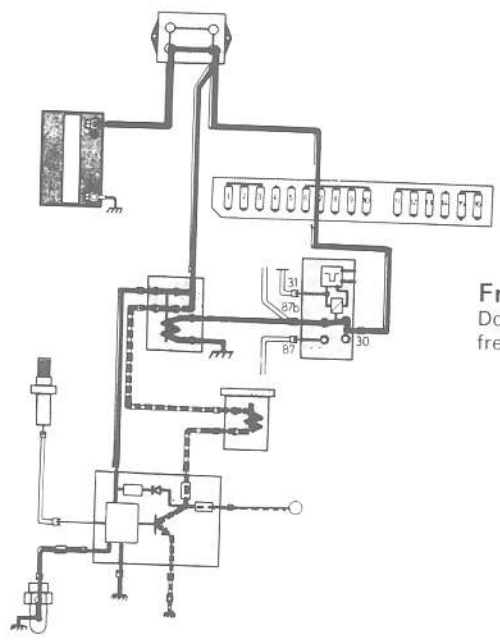

Frequency valve operating

Dotted line indicates frequency valve current

LAMBDA SOND COMPONENT PLACEMENT
260 series/1979

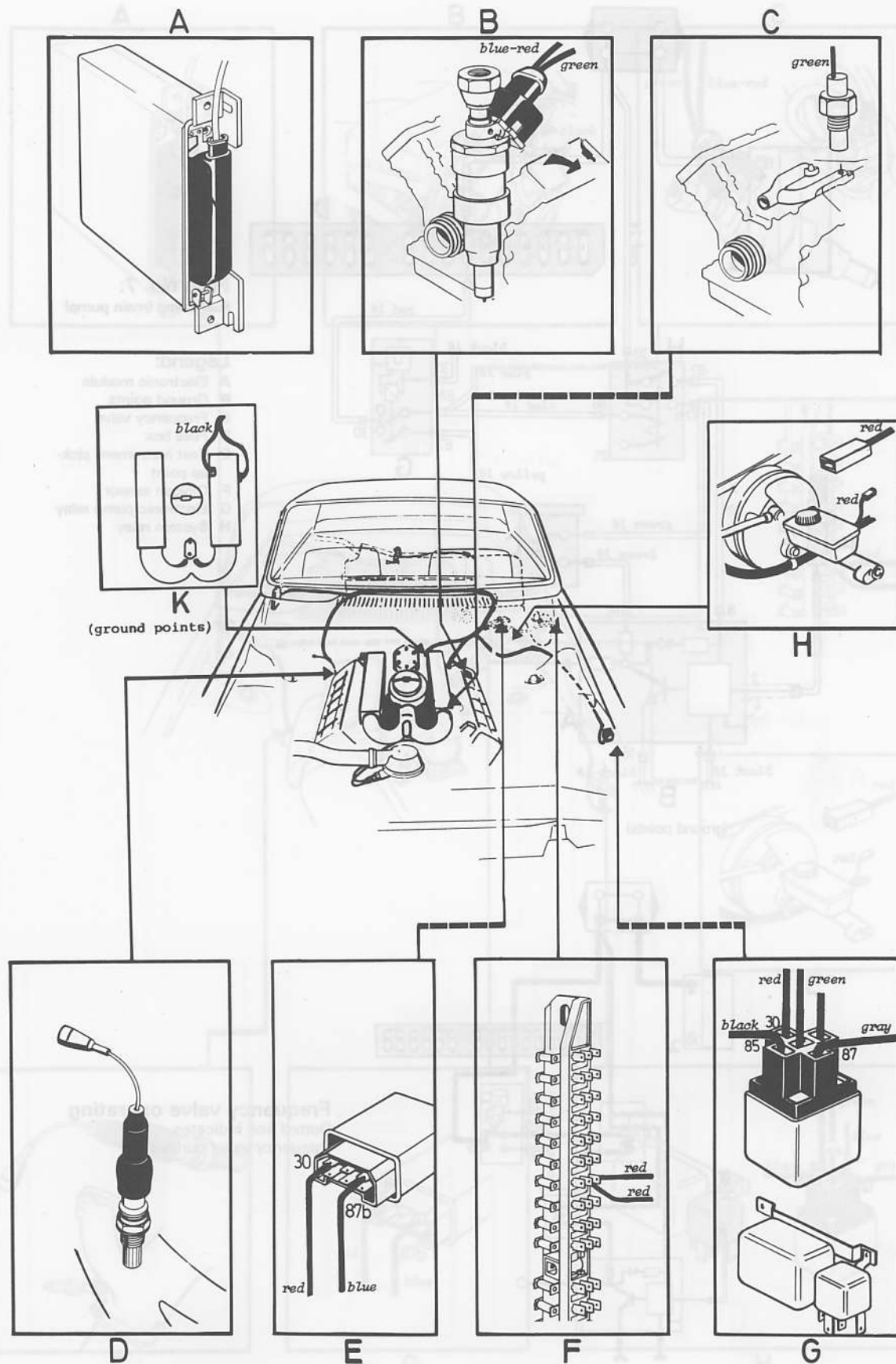

LAMBDA SOND WIRING DIAGRAM
B21F/1980

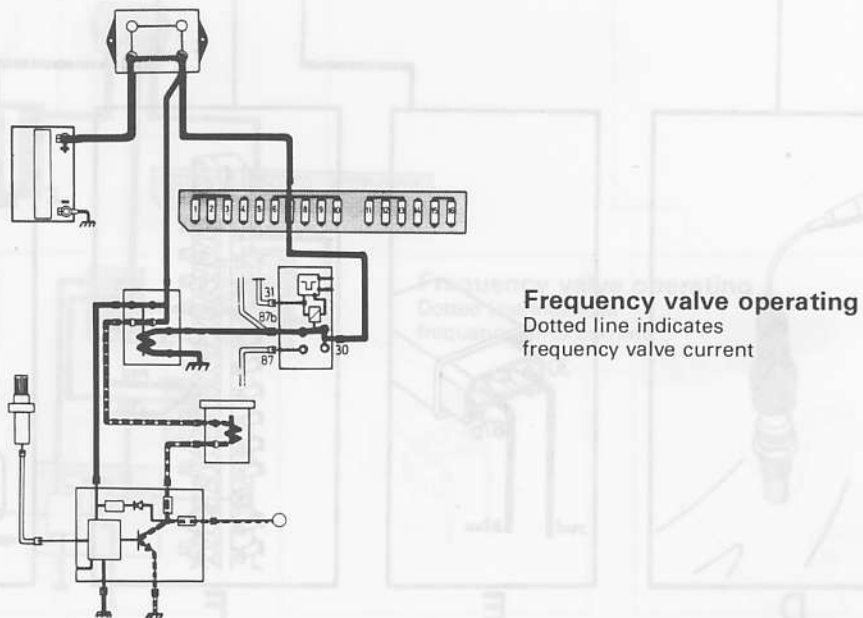
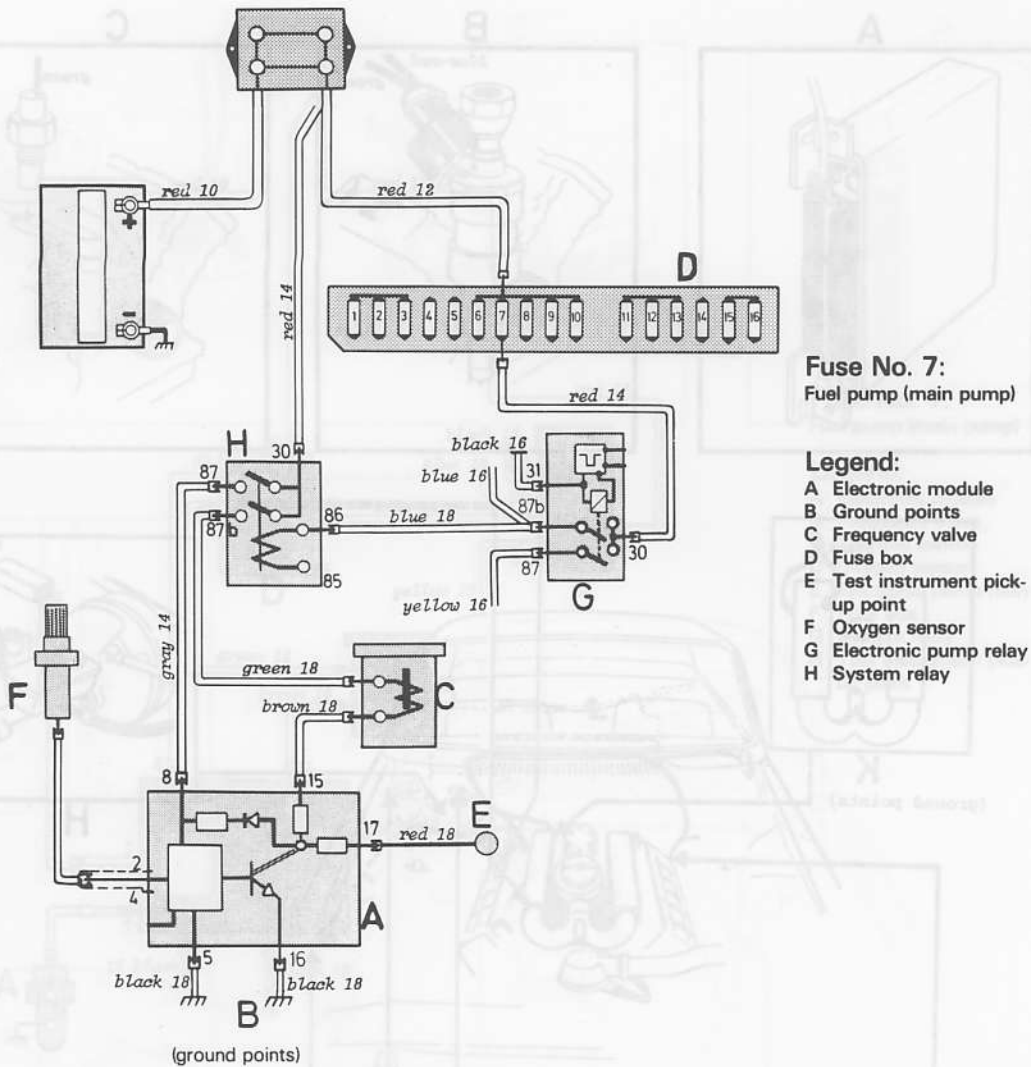

LAMBDA SOND COMPONENT PLACEMENT
B21F/1980

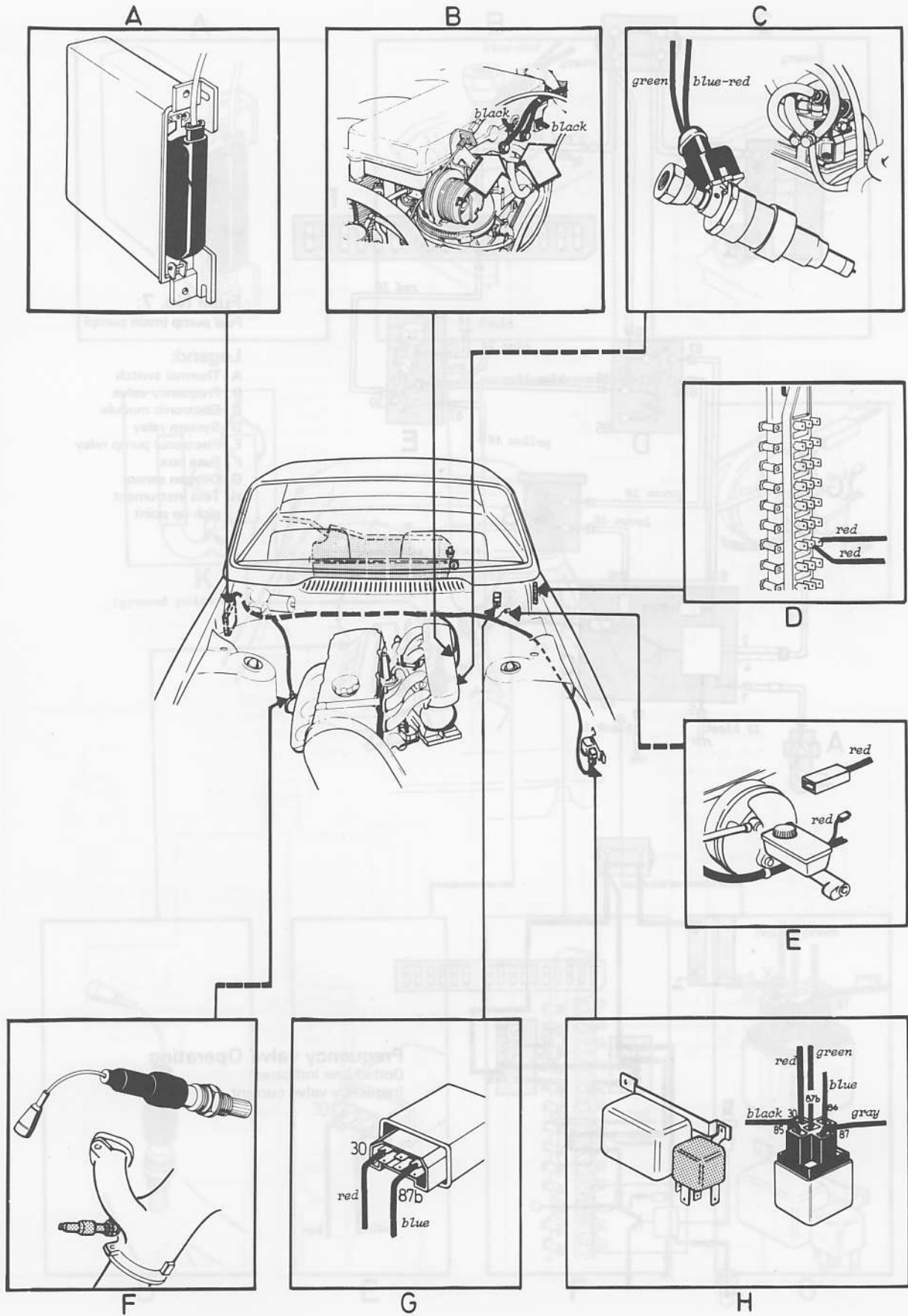

LAMBDA SOND WIRING DIAGRAM
B28F/1980

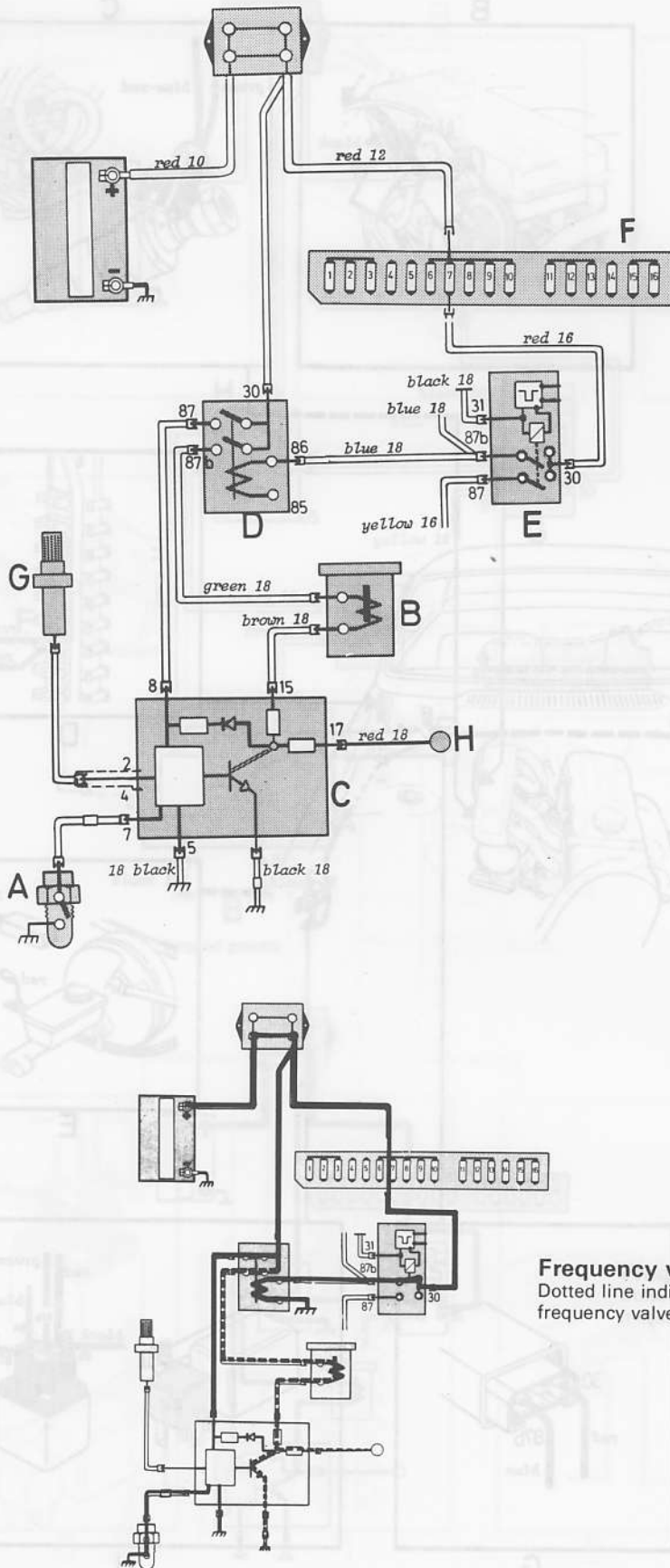

Fuse No. 7:
Fuel pump (main pump)

Legend:

- A Thermal switch
- B Frequency valve
- C Electronic module
- D System relay
- E Electronic pump relay
- F Fuse box
- G Oxygen sensor
- H Test instrument pick-up point

Frequency valve Operating

Dotted line indicates frequency valve current

LAMBDA SOND COMPONENT PLACEMENT
B28F/1980

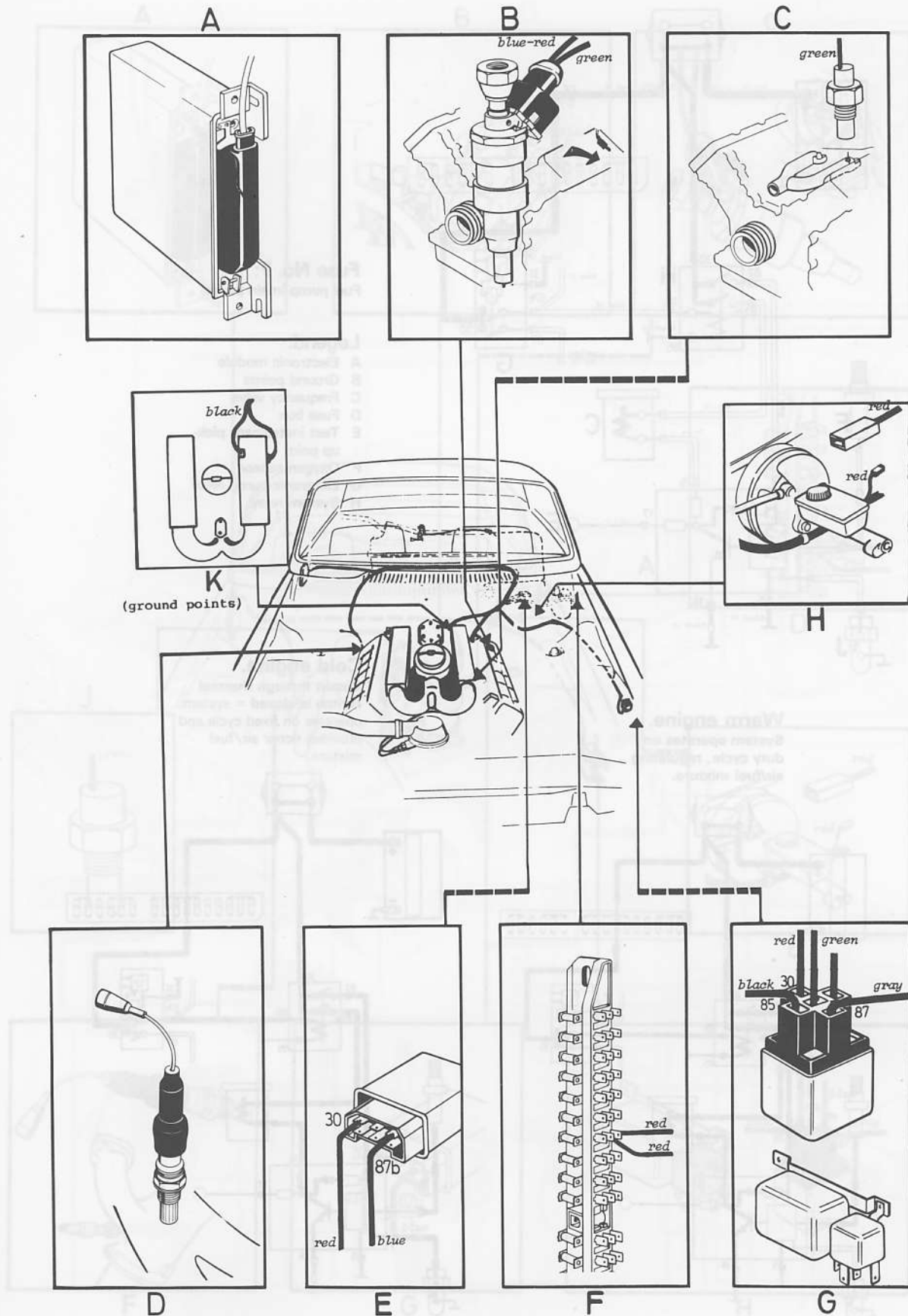

-Lambda Sond-

LAMBDA SOND WIRING DIAGRAM
B21F/1981

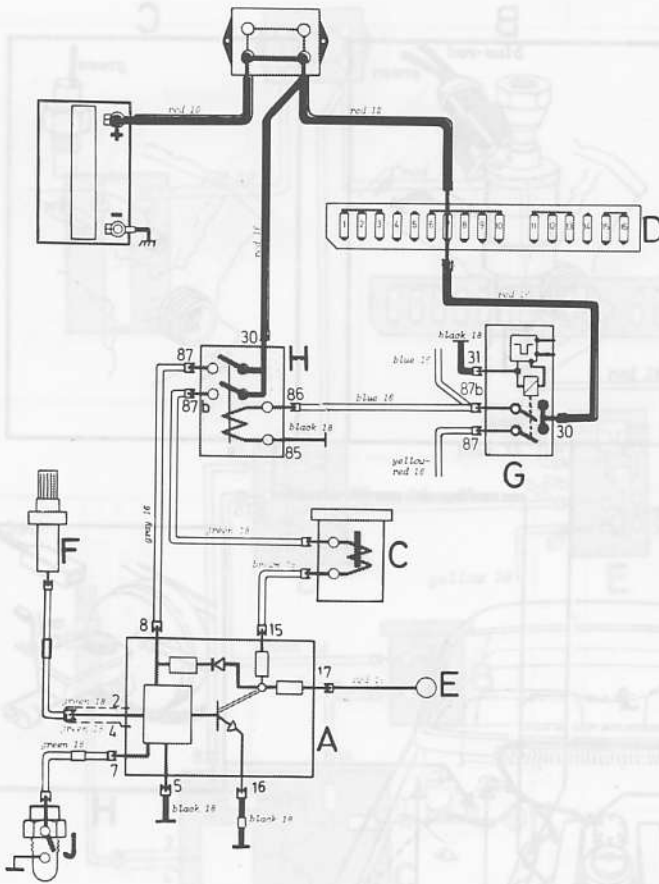

Fuse No. 7:
Fuel pump (main pump)

Legend:

- A Electronic module
- B Ground points
- C Frequency valve
- D Fuse box
- E Test instrument pick-up point
- F Oxygen sensor
- G Electronic pump relay
- H System relay

Warm engine.
System operates on duty cycle, regulating air/fuel mixture.

Cold engine.
Circuit through thermal switch is closed = system operates on fixed cycle and provides richer air/fuel mixture.

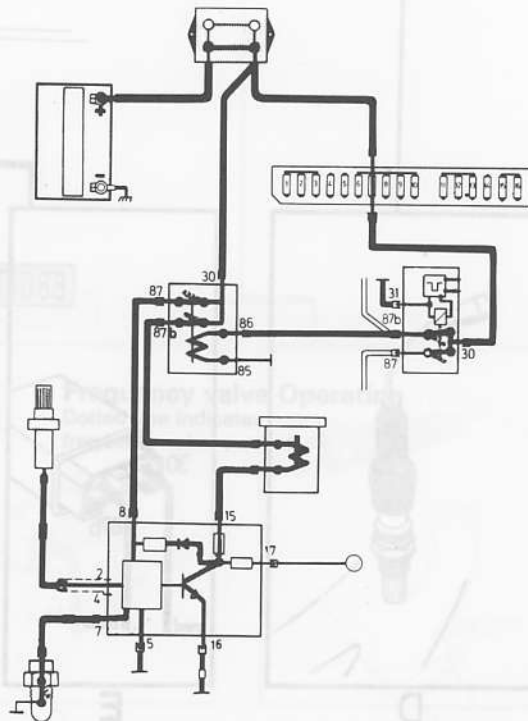
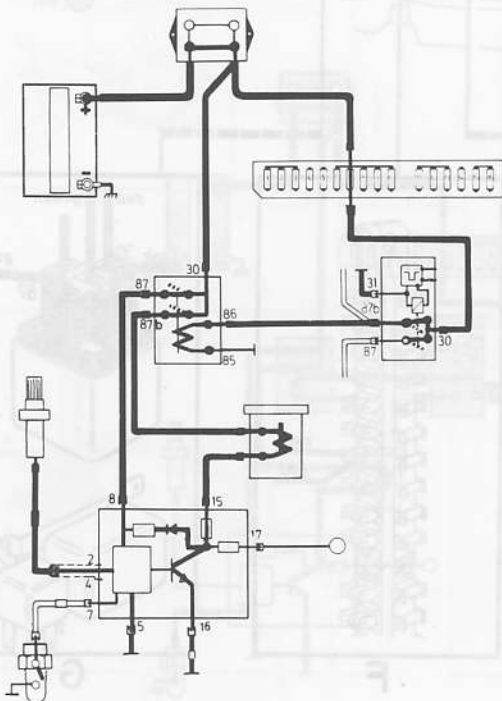

LAMBDA SOND COMPONENT PLACEMENT
B21F/1981

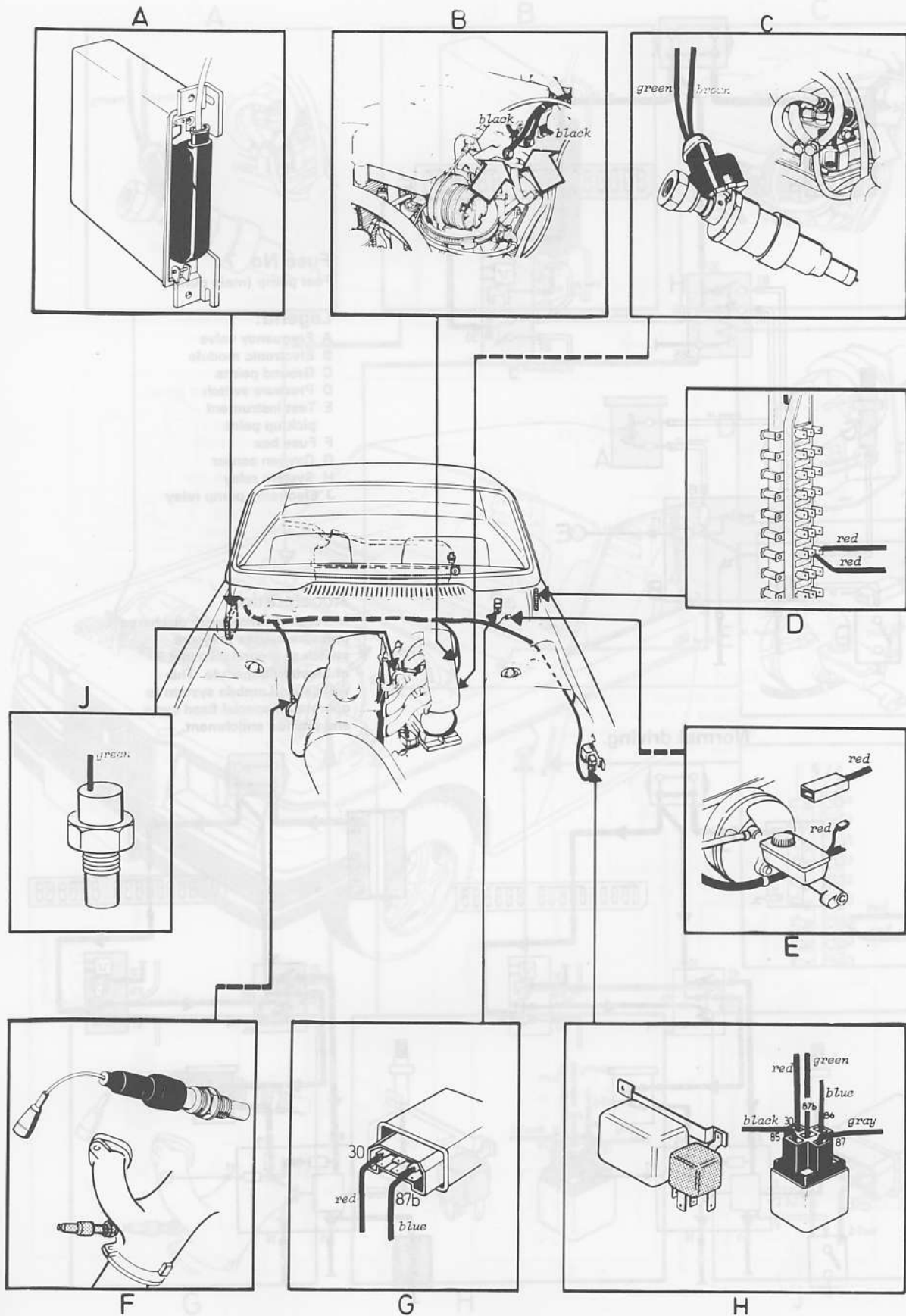

LAMBDA SOND WIRING DIAGRAM
B21F Turbo/1981

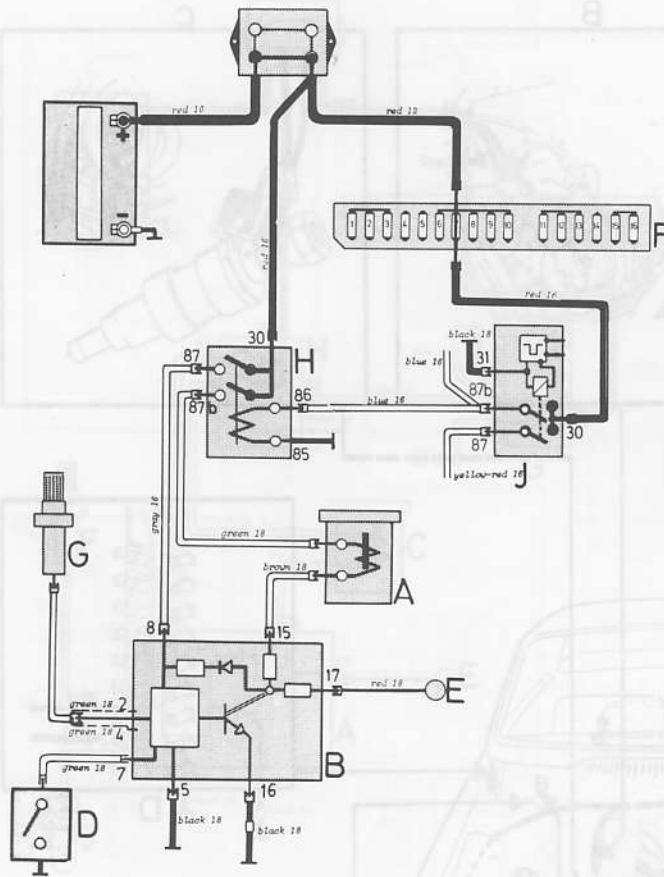

Fuse No. 7:
Fuel pump (main pump)

Legend:

- A Frequency valve
- B Electronic module
- C Ground points
- D Pressure switch
- E Test instrument pick-up point
- F Fuse box
- G Oxygen sensor
- H System relay
- J Electronic pump relay

Acceleration.

Increasing compressor discharge pressure causes pressure switch to ground terminal 7 of Electronic module. This will cause Lambda system to operate on special fixed cycle and provide enrichment.

Normal driving.

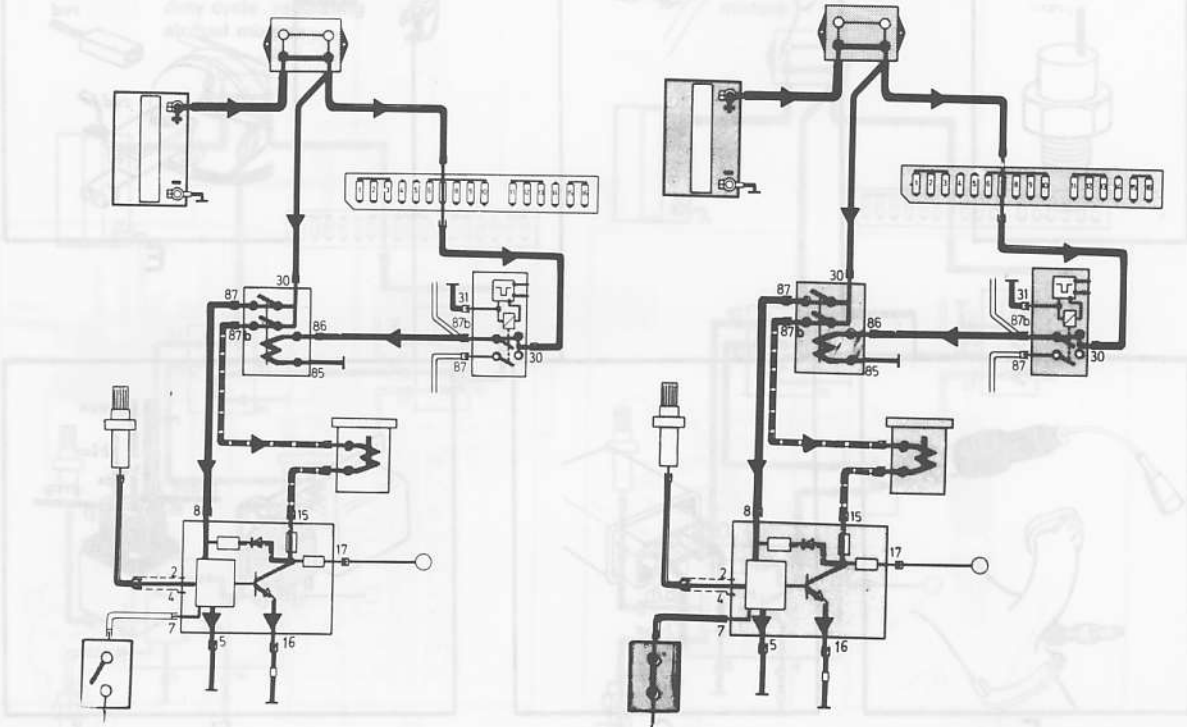

LAMBDA SOND COMPONENT PLACEMENT B21F Turbo/1981

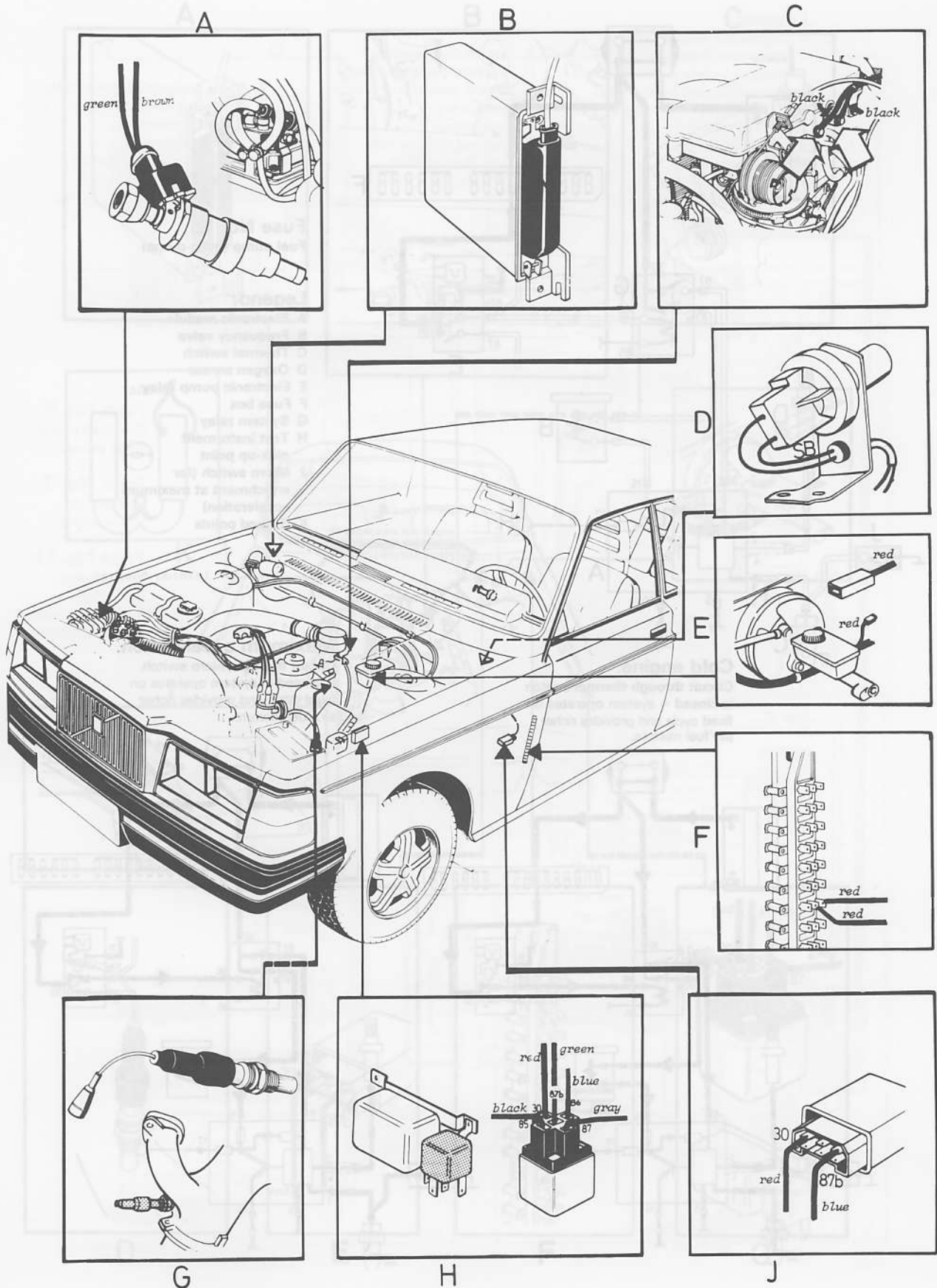

LAMBDA SOND WIRING DIAGRAM
B28F/1981

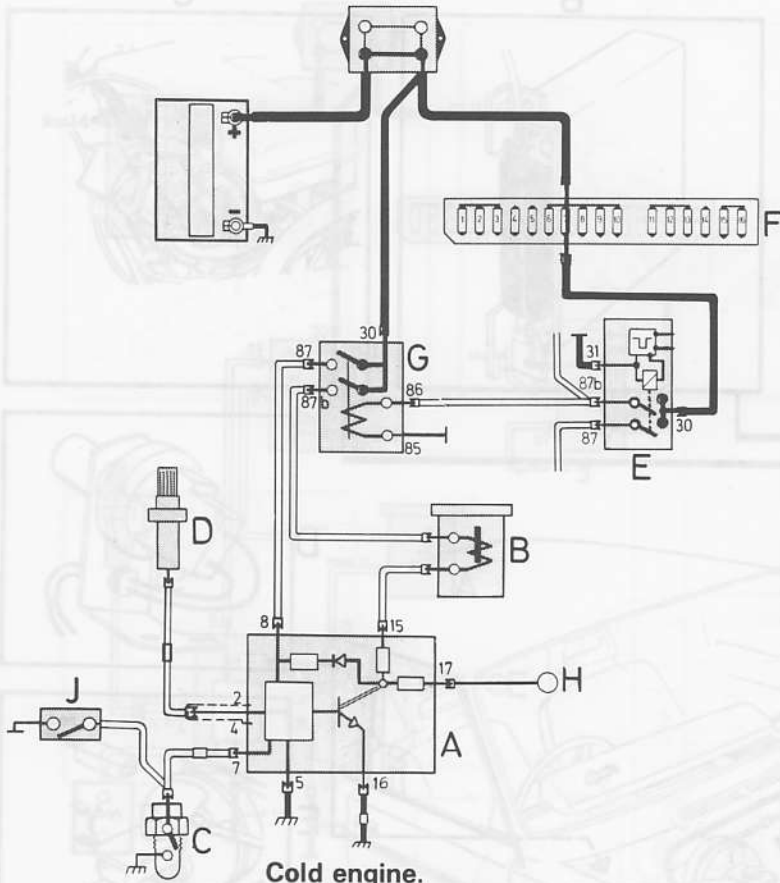

Fuse No. 7:
Fuel pump (main pump)

- Legend:**
- A Electronic module
 - B Frequency valve
 - C Thermal switch
 - D Oxygen sensor
 - E Electronic pump relay
 - F Fuse box
 - G System relay
 - H Test instrument pick-up point
 - J Micro switch (for enrichment at maximum acceleration)
 - K Ground points

Cold engine.
Circuit through thermal switch is closed = system operates on fixed cycle and provides richer air/fuel mixture.

Maximum acceleration.
Circuit through micro switch is closed = system operates on fixed cycle and provides richer air/fuel mixture.

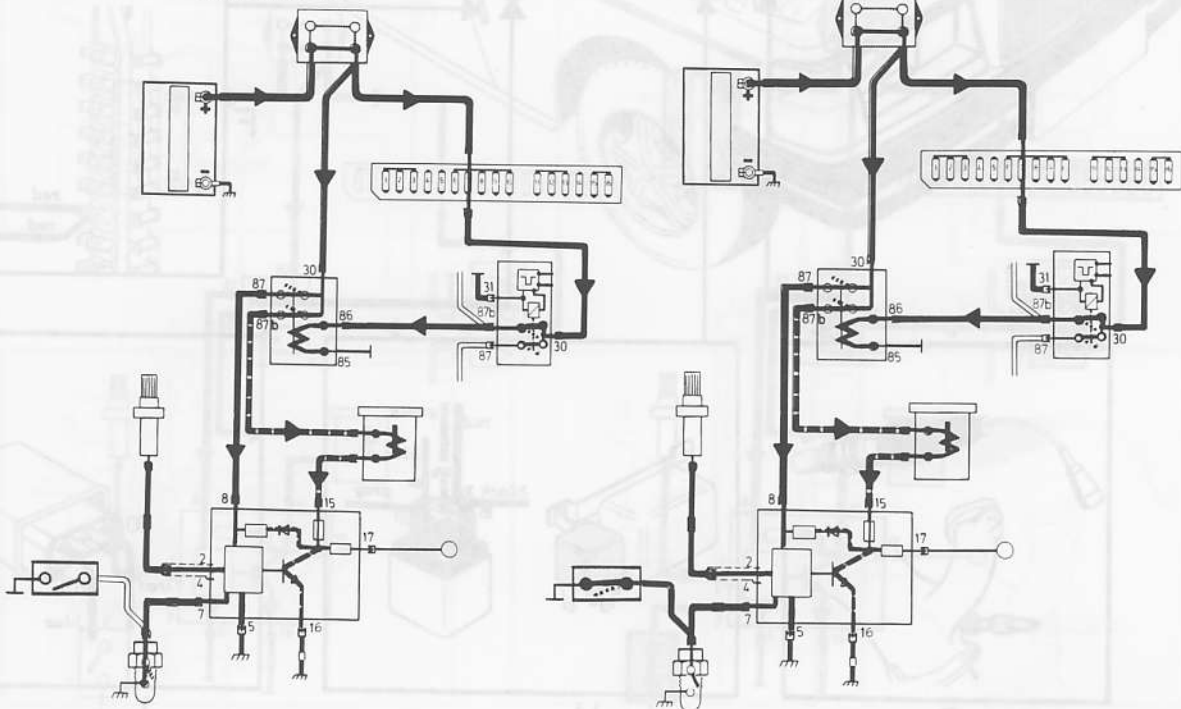

LAMBDA SOND COMPONENT PLACEMENT
B28F/1981

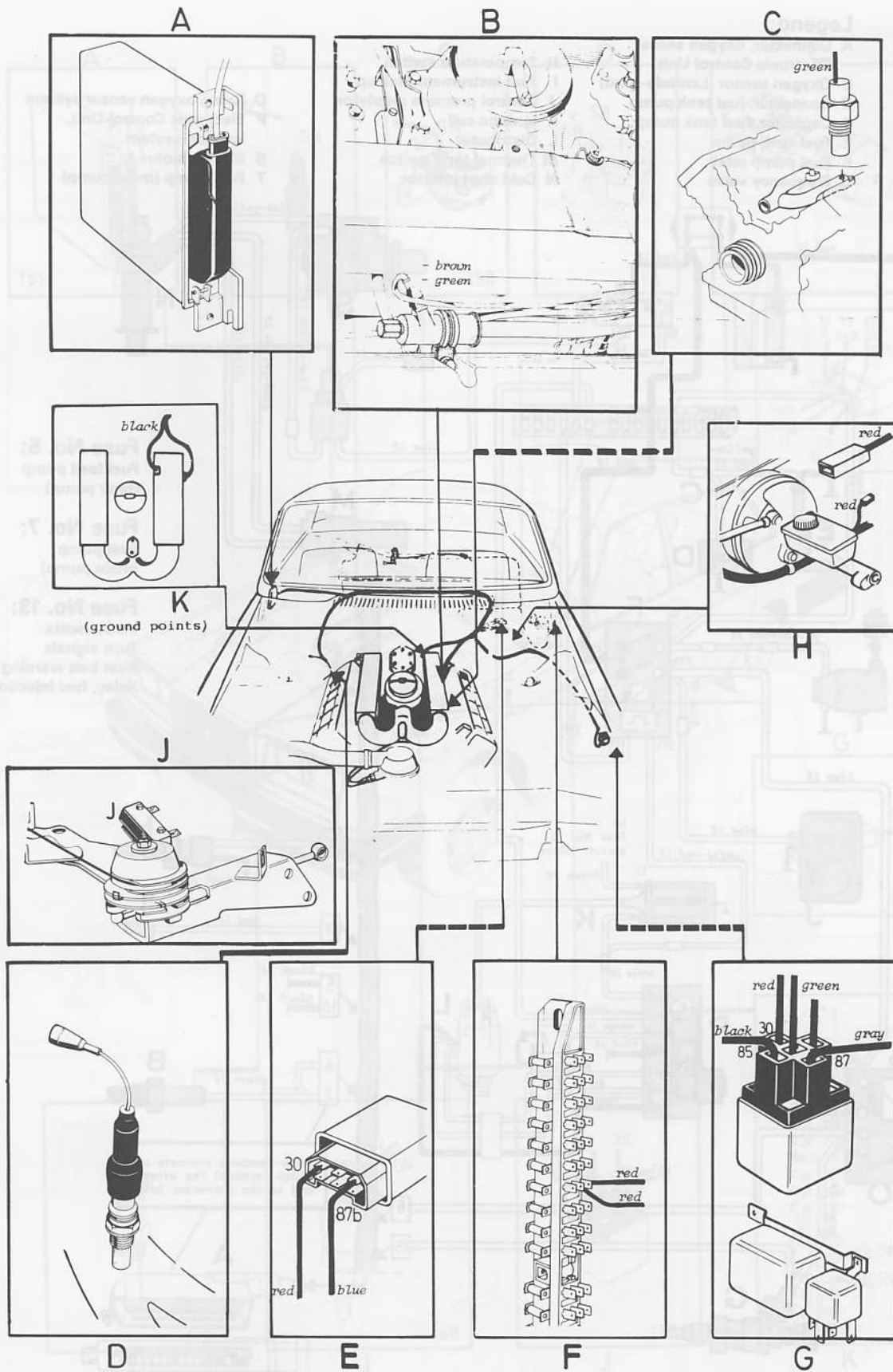

LAMBDA SOND WIRING DIAGRAM
B21F/1982

Legend:

- | | | |
|-------------------------------|------------------------------|--|
| A Connector, oxygen sensor | H Temperature switch | O Relay, oxygen sensor system |
| B Oxygen sensor (Lambda-sond) | I Test instrument pick-up | P Electronic Control Unit, ignition system |
| C Connector, fuel tank pump | J Control pressure regulator | S Starter motor |
| D Capacitor, fuel tank pump | K Ignition coil | T Fuel pump (main pump) |
| E Fuel tank pump | L Distributor | |
| F Fuel pump relay | M Thermal time switch | |
| G Frequency valve | N Cold start injector | |

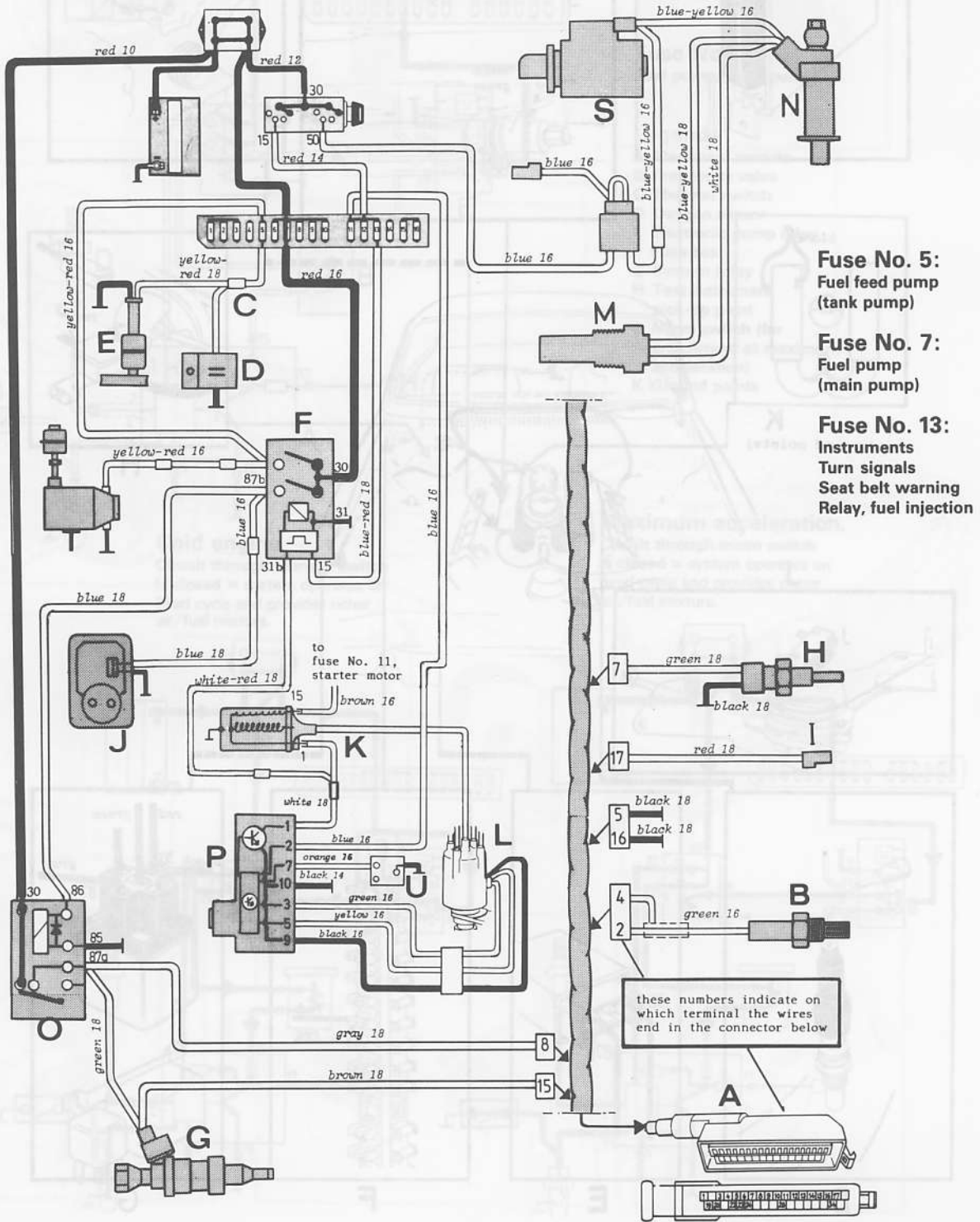

Fuse No. 5:
Fuel feed pump
(tank pump)

Fuse No. 7:
Fuel pump
(main pump)

Fuse No. 13:
Instruments
Turn signals
Seat belt warning
Relay, fuel injection

these numbers indicate on which terminal the wires end in the connector below

LAMBDA SOND COMPONENT PLACEMENT
B21F/1982

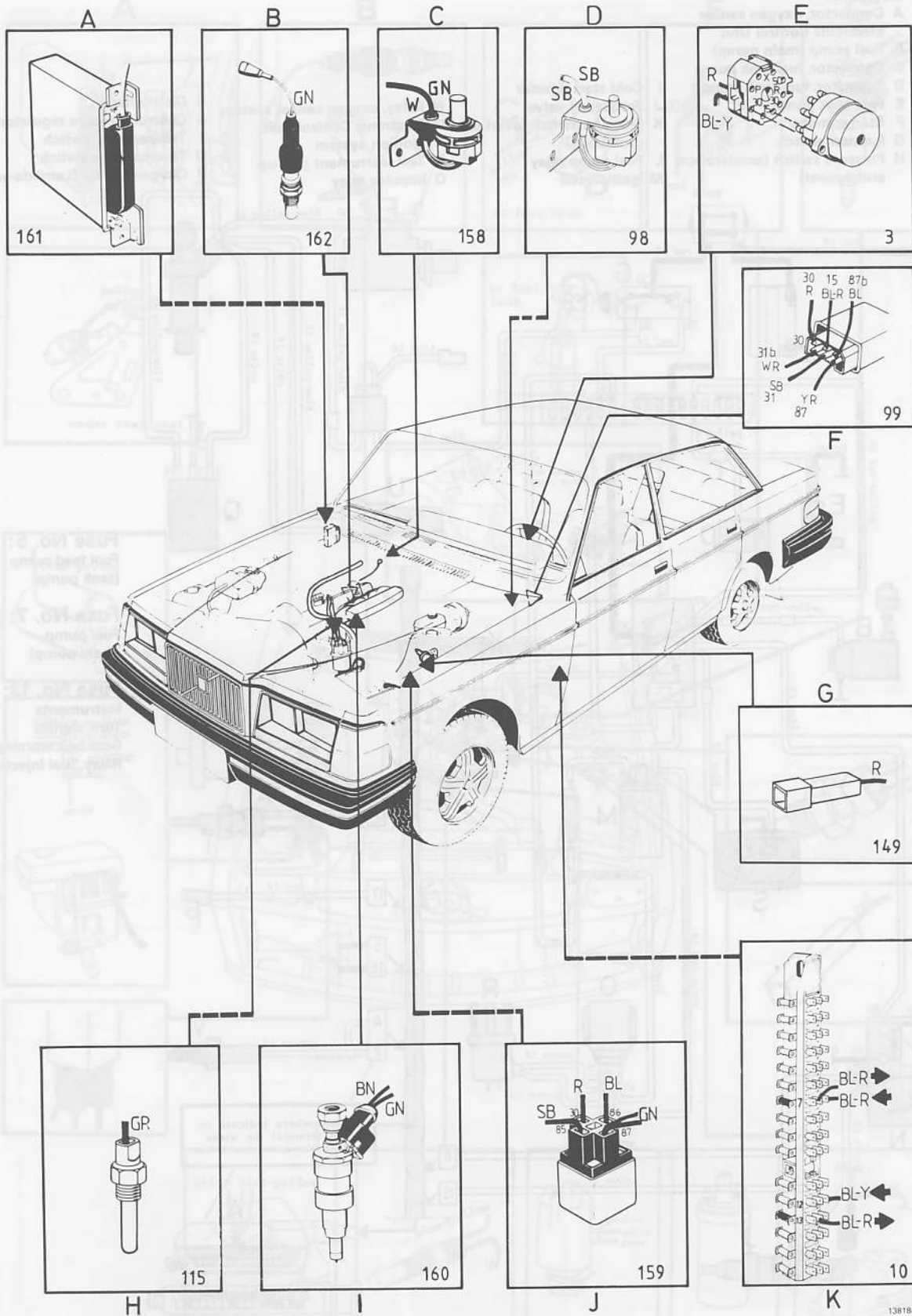

138184-H

LAMBDA SOND WIRING DIAGRAM
B21F Turbo/1982

Legend:

- | | | | |
|---|---|--|-------------------------------|
| A Connector, oxygen sensor | I Cold start injector | N Relay, oxygen sensor system | R Distributor |
| Electronic Control Unit | J Frequency valve | O Electronic Control Unit, ignition system | S Control pressure regulator |
| B Fuel pump (main pump) | K Pressure switch (overload protection) | P Test instrument pick-up | T Temperature switch |
| C Connector, fuel tank pump | L Fuel pump relay | Q Impulse relay | U Thermal time switch |
| D Capacitor, fuel tank pump | M Ignition coil | | V Oxygen sensor (Lambda-sond) |
| E Fuel tank pump | | | |
| F Starter motor | | | |
| G Ignition switch | | | |
| H Pressure switch (acceleration enrichment) | | | |

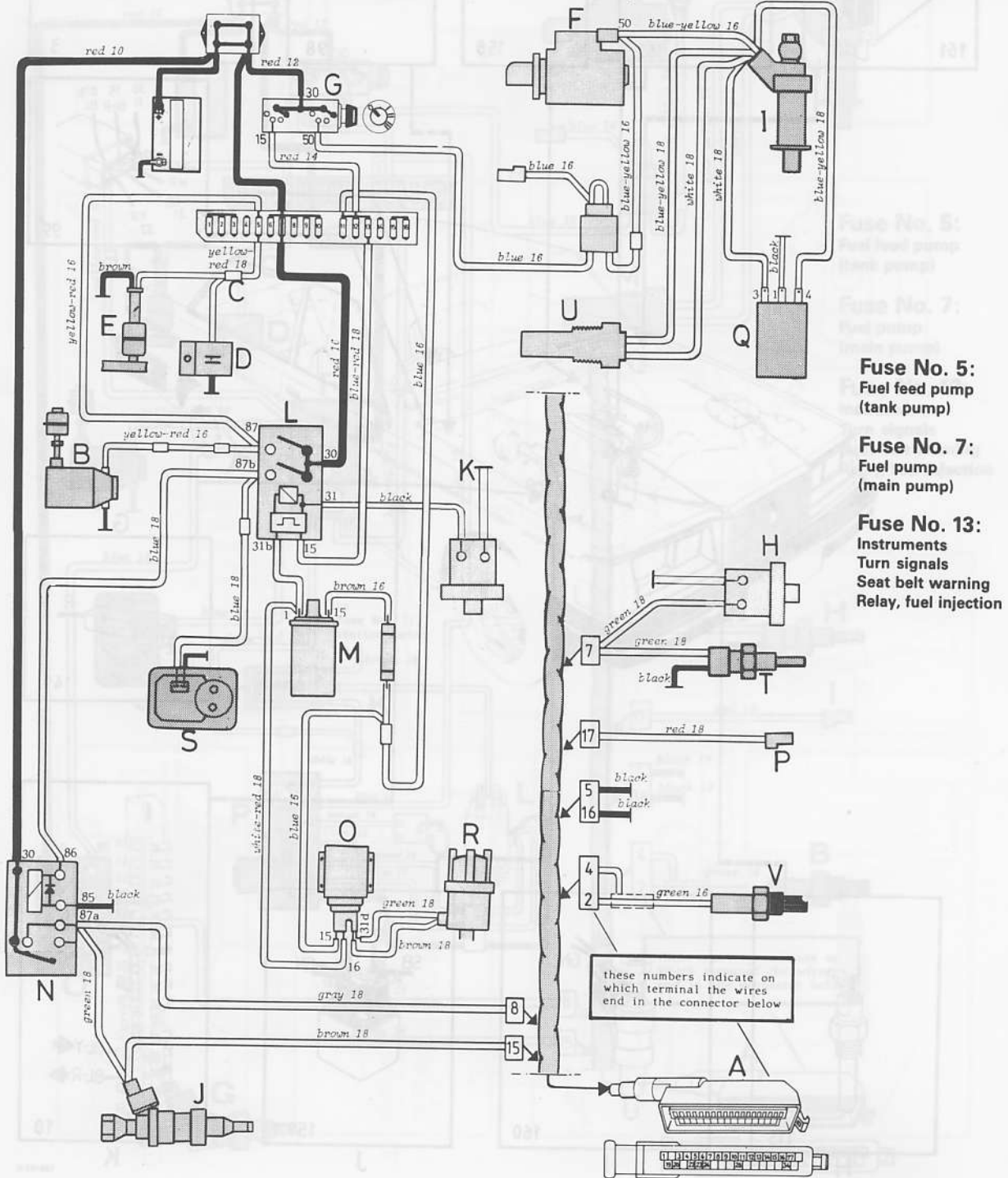

LAMBDA SOND COMPONENT PLACEMENT
B21F Turbo/1982

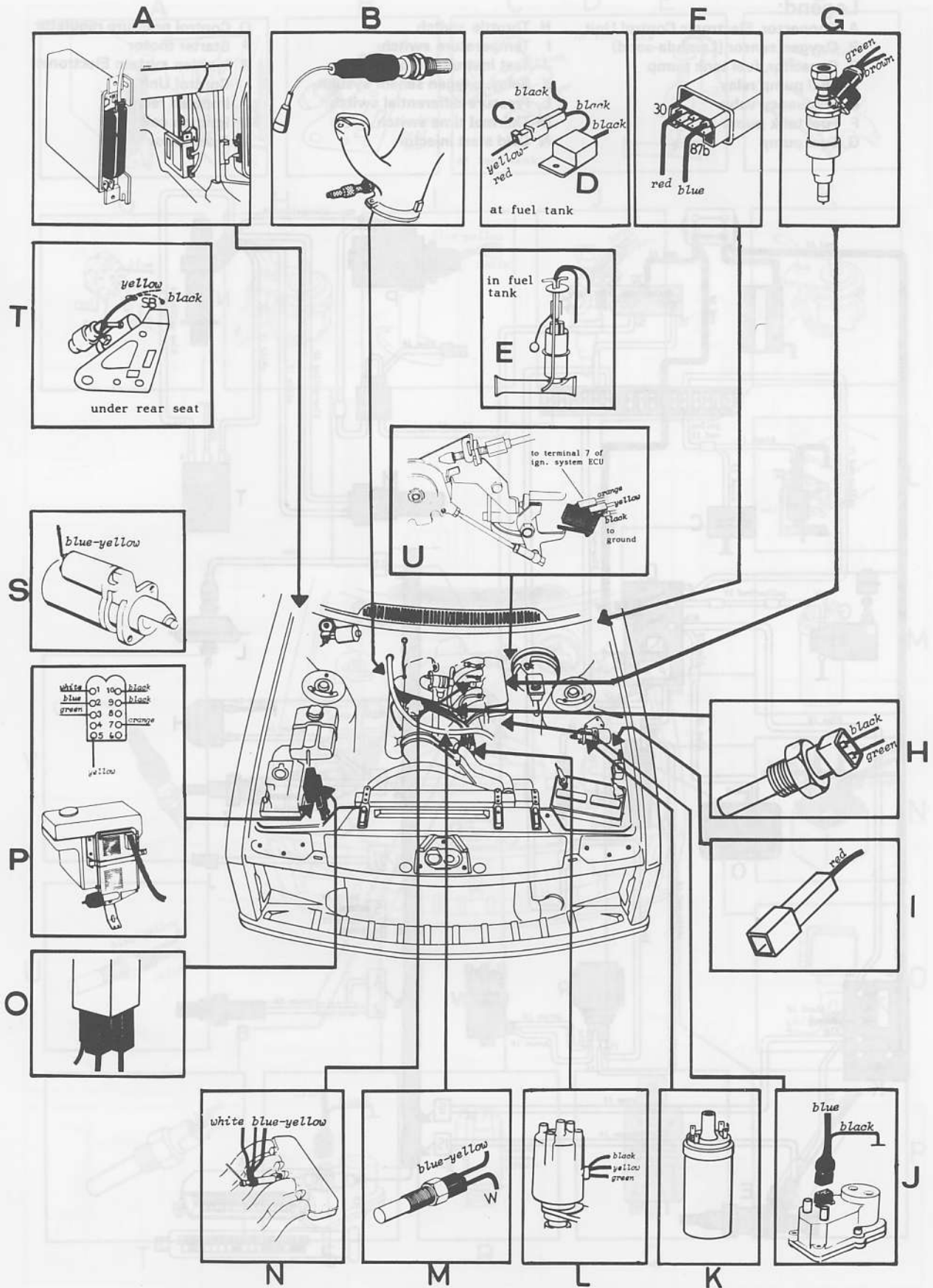

-Lambda Sond-

THE LAMBDA SOND WIRING DIAGRAM
B28F/1982

Legend:

- A Connector, Electronic Control Unit
- B Oxygen sensor (Lambda-sond)
- C Capacitor, fuel tank pump
- D Fuel pump relay
- E Frequency valve
- F Fuel tank pump
- G Fuel pump

- H Throttle switch
- I Temperature switch
- J Test instrument pick-up
- K Relay, oxygen sensor system
- L Pressure differential switch
- M Thermal time switch
- N Cold start injector

- O Control pressure regulator
- P Starter motor
- R Ignition system Electronic Control Unit
- T Impulse relay
- U Ignition coil
- V Distributor

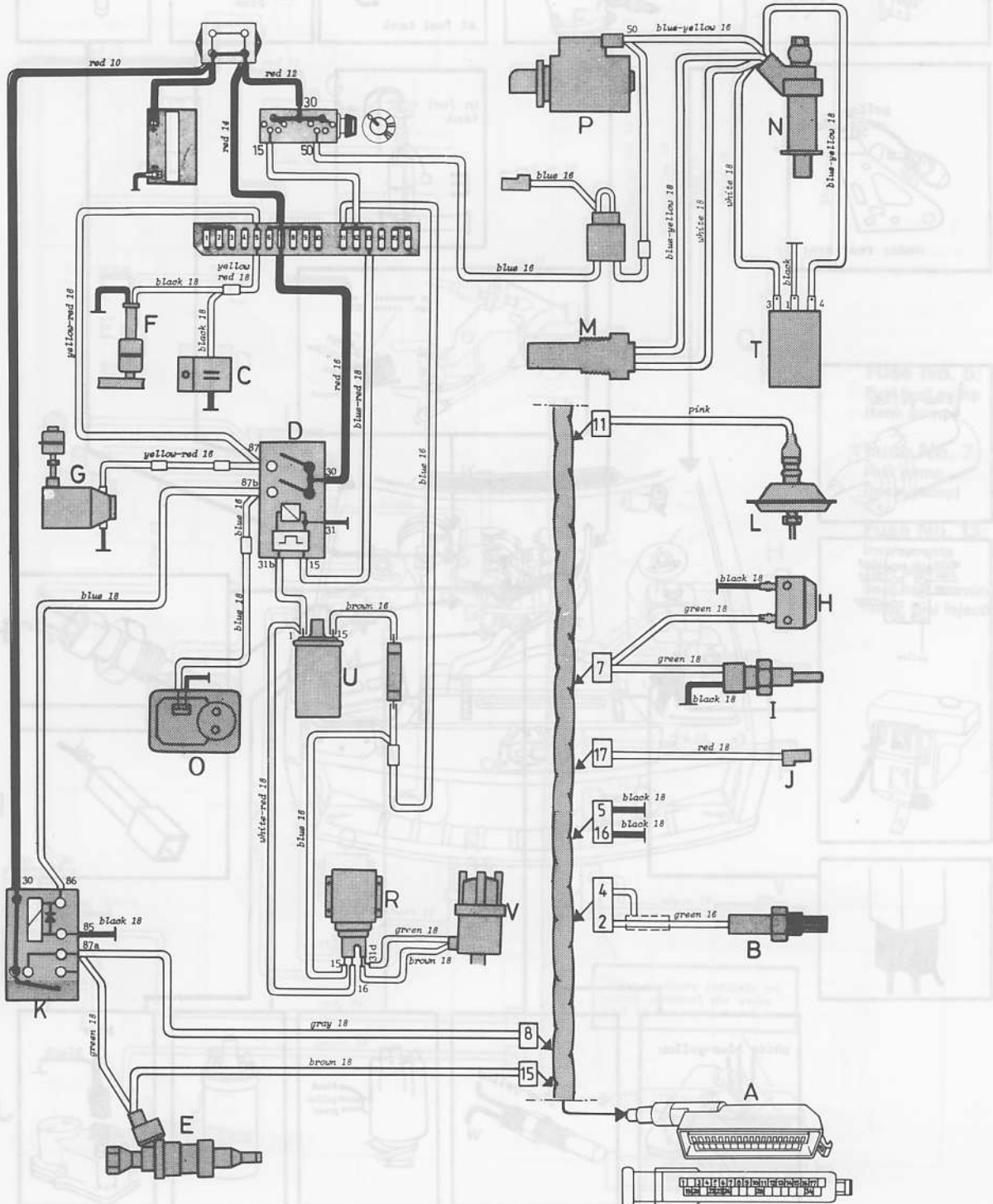

LAMBDA SOND COMPONENT PLACEMENT
B28F/1982

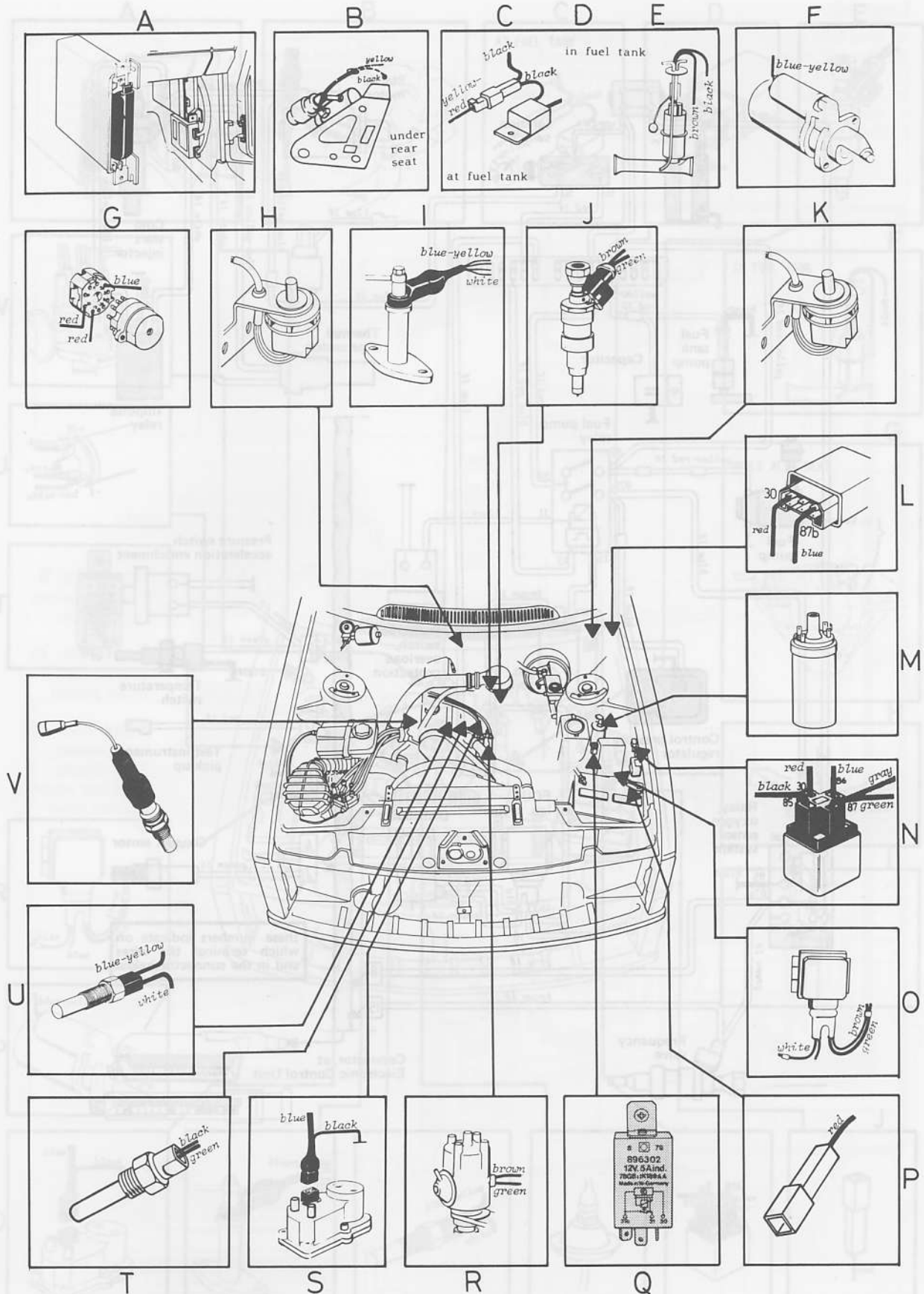

LAMBDA SOND WIRING DIAGRAM B21F Turbo/1983

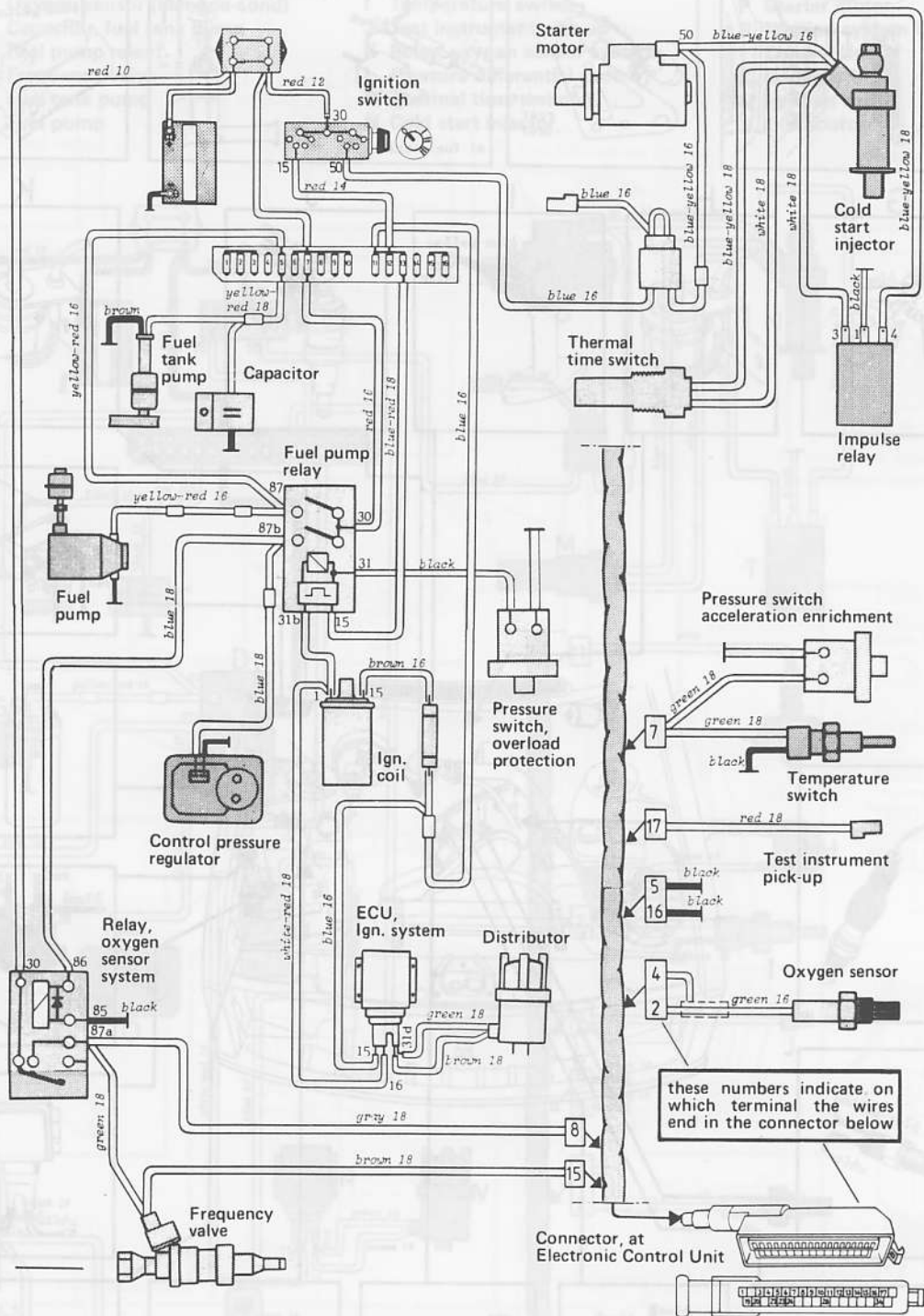

LAMBDA SOND COMPONENT PLACEMENT
B21F Turbo/1983

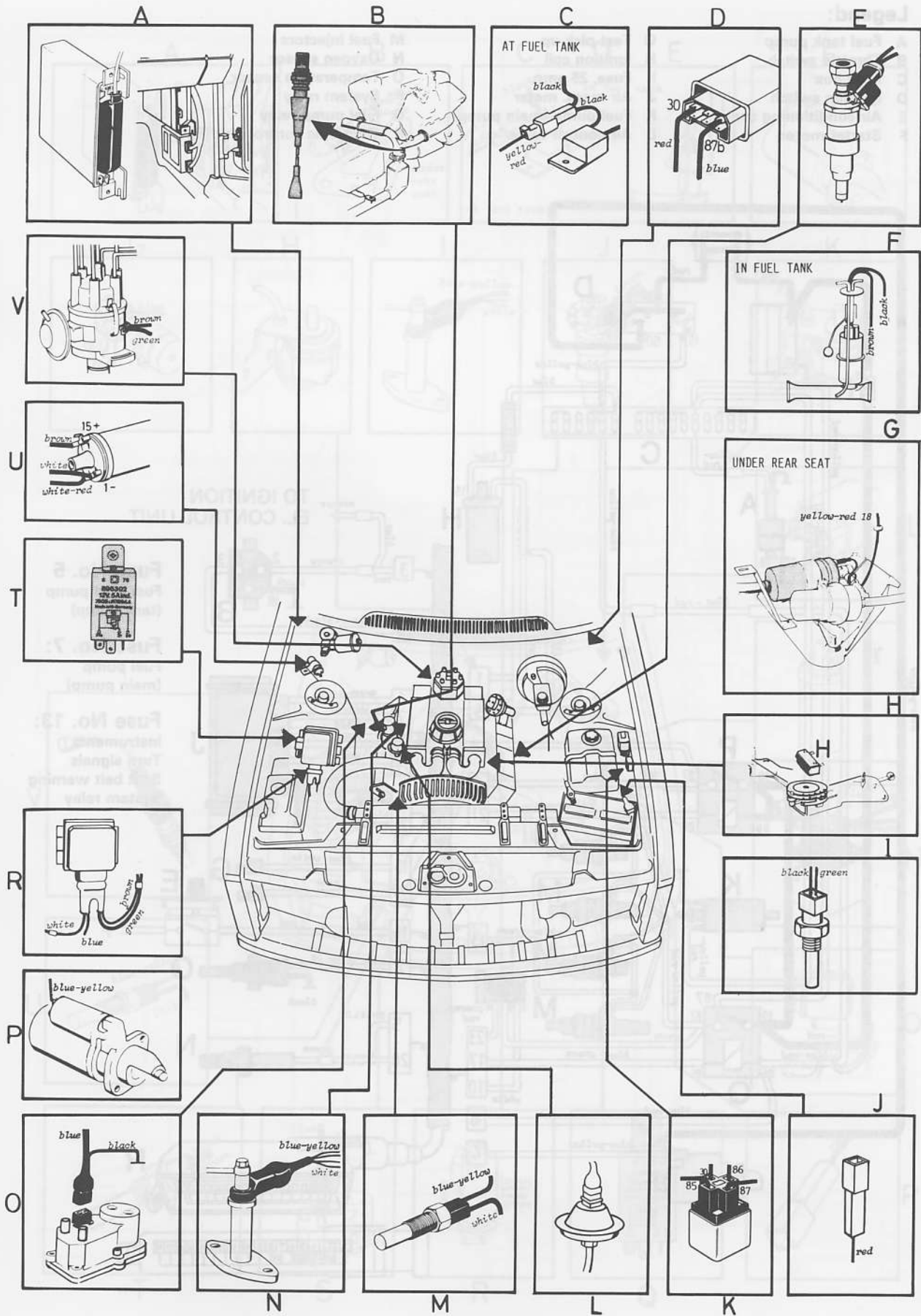

LAMBDA SOND WIRING DIAGRAM
B23F/1983

Legend:

- | | | |
|---------------------------|-------------------------|---------------------------------|
| A Fuel tank pump | G Test pick-up | M Fuel injectors |
| B Throttle switch | H Ignition coil | N Oxygen sensor |
| C Fuse box | I Fuse, 25 amp. | O Temperature sensor |
| D Ignition switch | J Air mass. meter | P System relay |
| E Air conditioning switch | K Fuel pump (main pump) | Q Fuel pump relay |
| F Starter motor | L Air control valve | R Electronic control unit (ECU) |

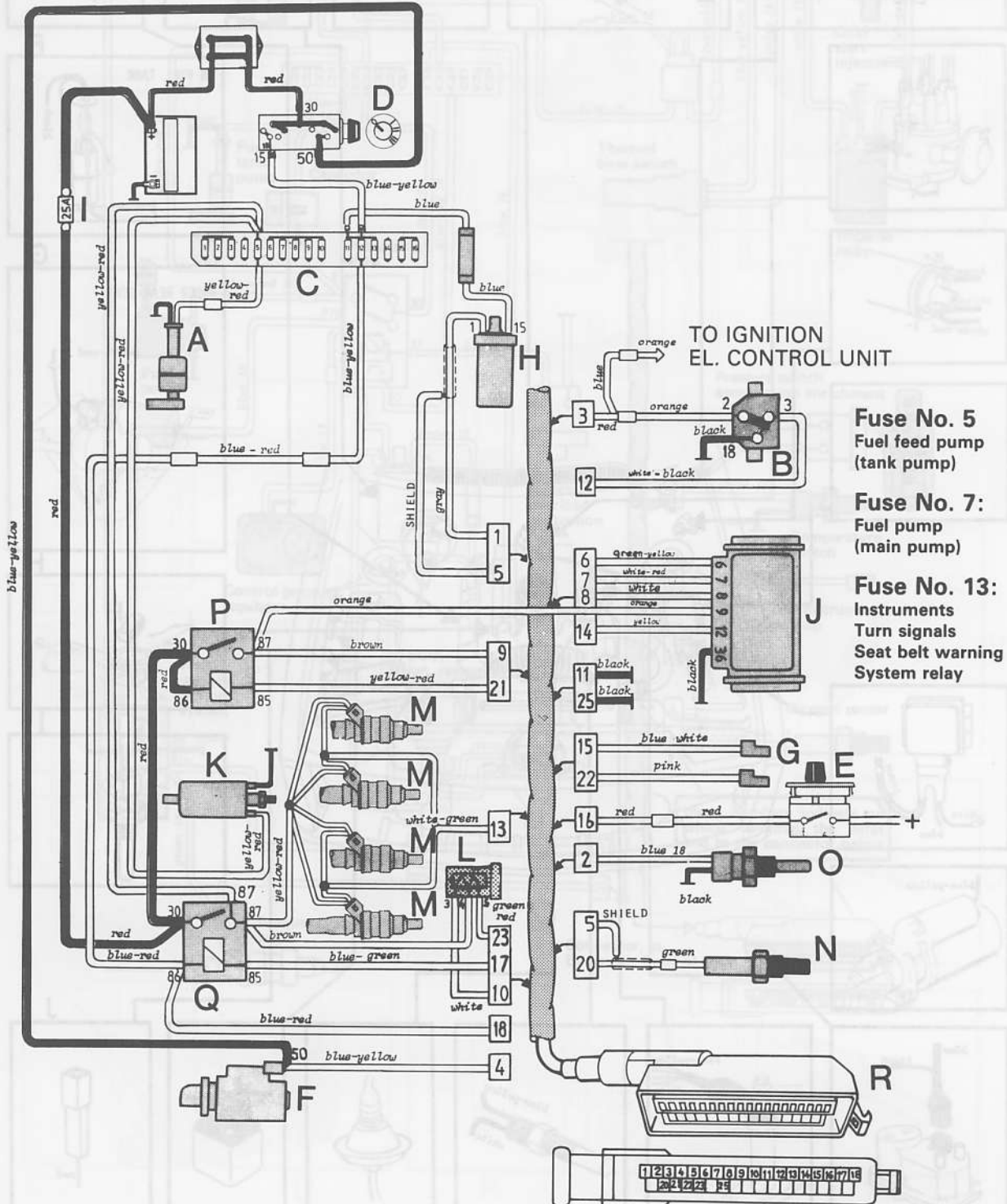

Fuse No. 5
Fuel feed pump
(tank pump)

Fuse No. 7:
Fuel pump
(main pump)

Fuse No. 13:
Instruments
Turn signals
Seat belt warning
System relay

-Lambda Sond-

LAMBDA SOND WIRING DIAGRAM
B23F, B21F Turbo/1984

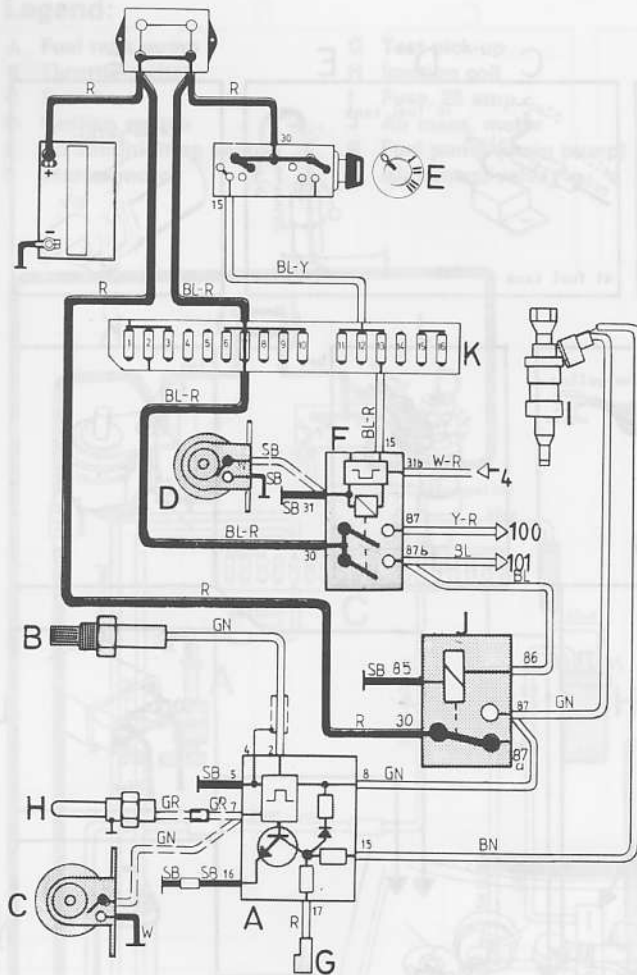

- A Control unit
- B Pressure enrichment sv.
- C Microswitch
- D Charge air overpressure swit Turbo
- E Ignition switch
- F Fuel pump relay
- G Lambda sond test point
- H Coolant temp switch
- I Frequency valve
- J Lambda sond system relay
- K Fusebox

Fuse No. 7
No other functions

Fuse No. 13
Combined instrument
Direction indicators

Fuse No. 8
Fuel Nozzle pump
Tank pump

Fuse No. 7:
Fuel pump
Main control

Fuse No. 12:
Ignition
Turbo engine
EGR back warning
Main relay

Engine running
Frequency valve in duty cycle

Engine running
Frequency valve engaged

Engine stalled

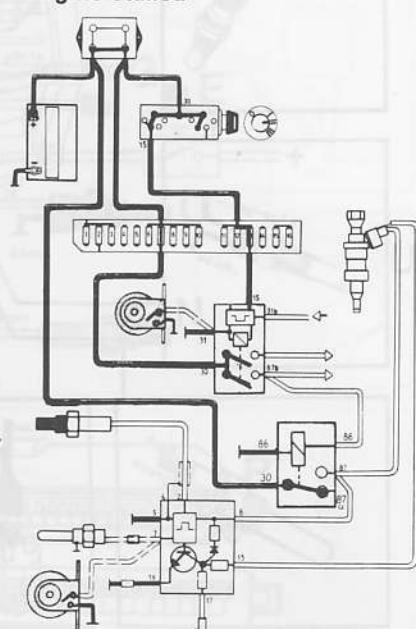
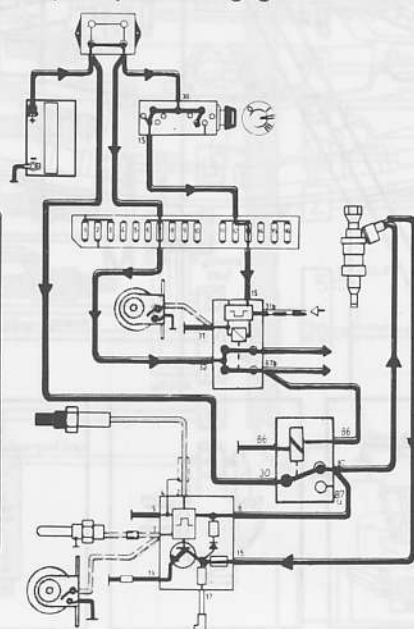
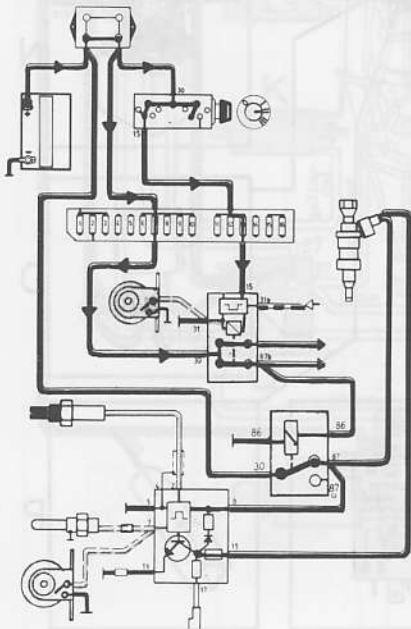

138184-V

LAMBDA SOND COMPONENT PLACEMENT
B23F, B21F Turbo/1984

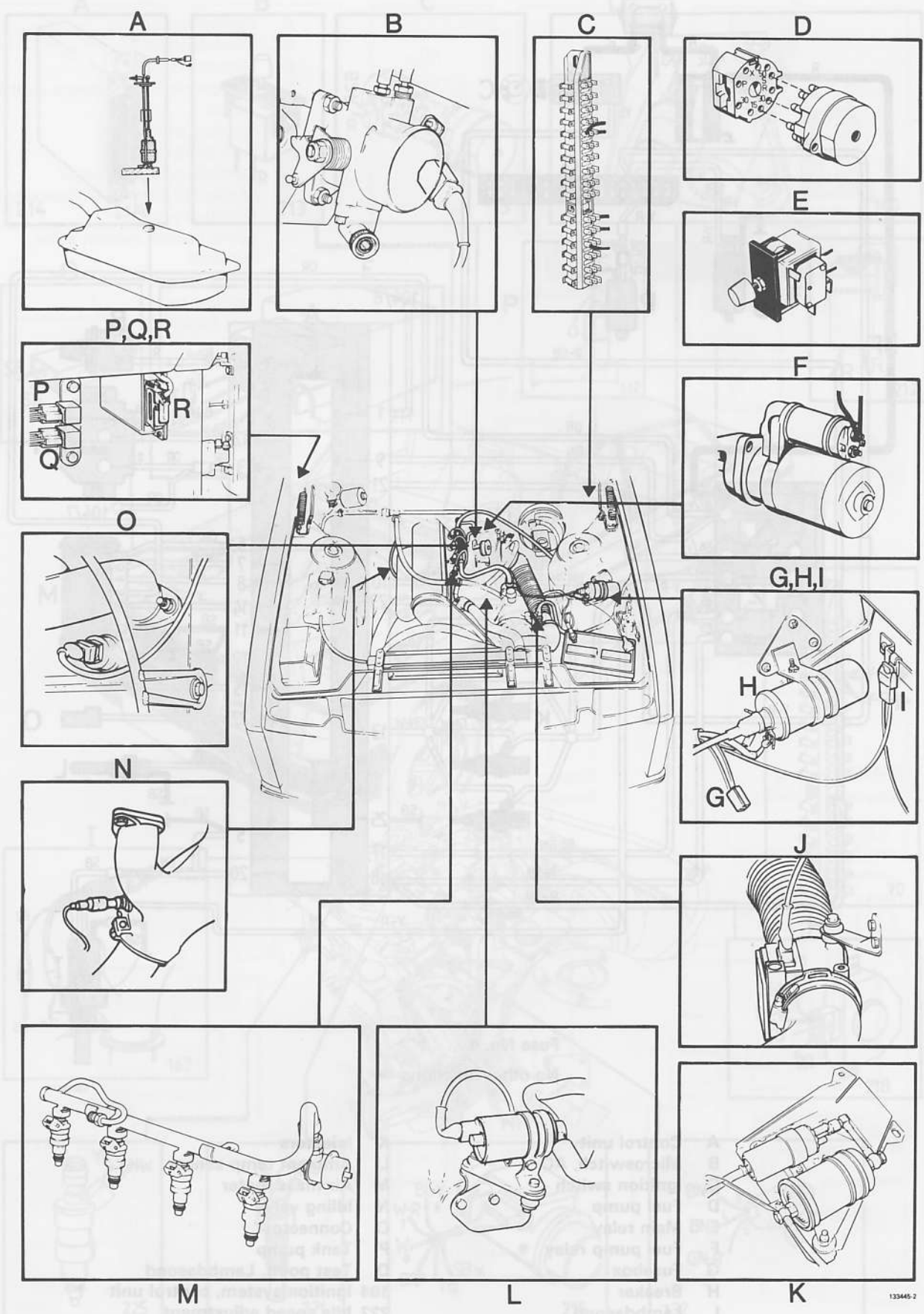

133445-2

-Lambda Sond-

LAMBDA SOND WIRING DIAGRAM
B230F, 1985

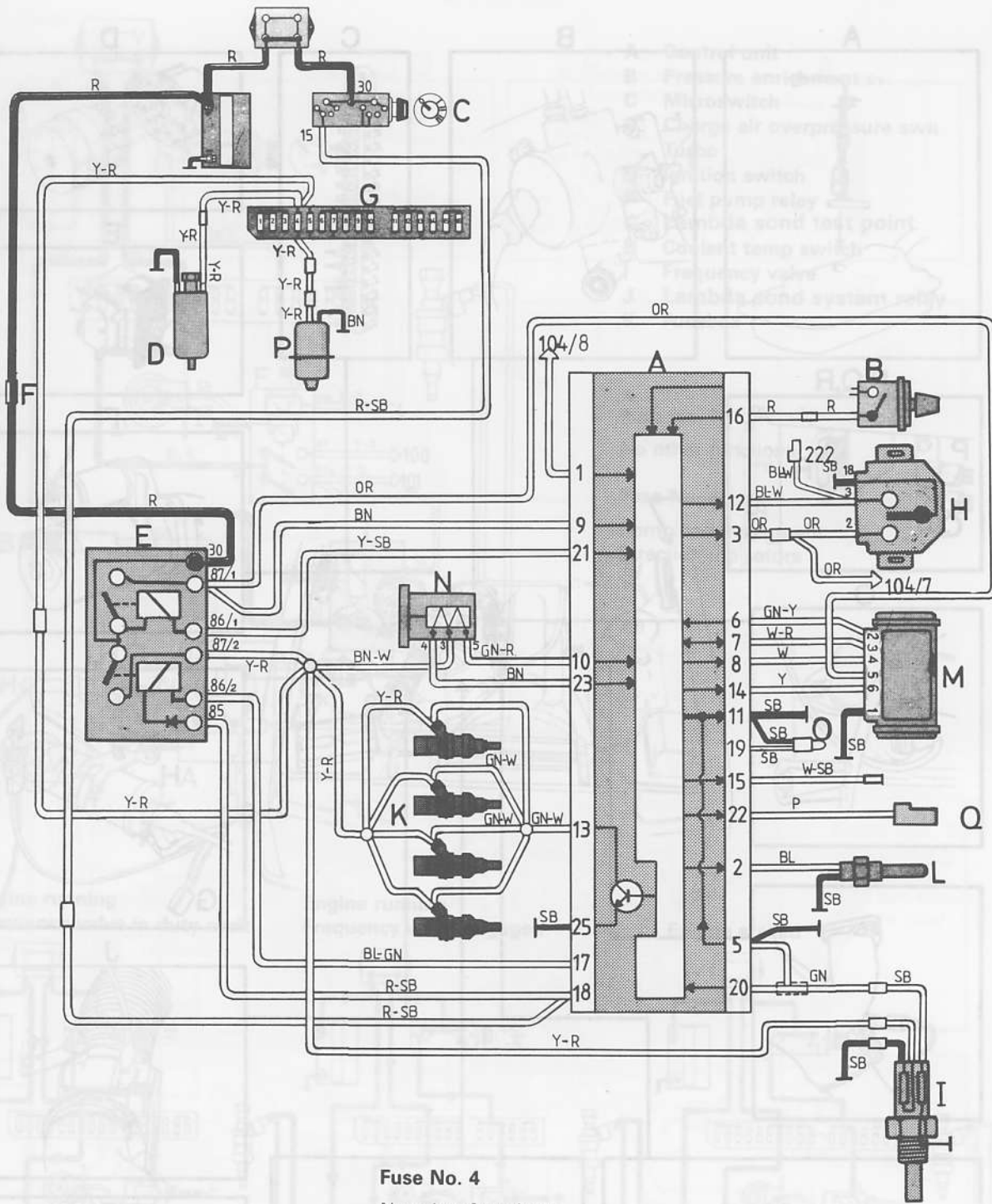

138182-V

- | | |
|--------------------------|--|
| A Control unit | K Injectors |
| B Microswitch, AC | L Ambient temp sensor |
| C Ignition switch | M Air mass meter |
| D Fuel pump | N Idling valve |
| E Main relay | O Connector |
| F Fuel pump relay | P Tank pump |
| G Fusebox | Q Test point, Lambdasond |
| H Breaker | 104 Ignition system, control unit |
| I Lambdasond | 222 Idle speed adjustment |

LAMBDA SOND COMPONENT PLACEMENT

B230F, 1985

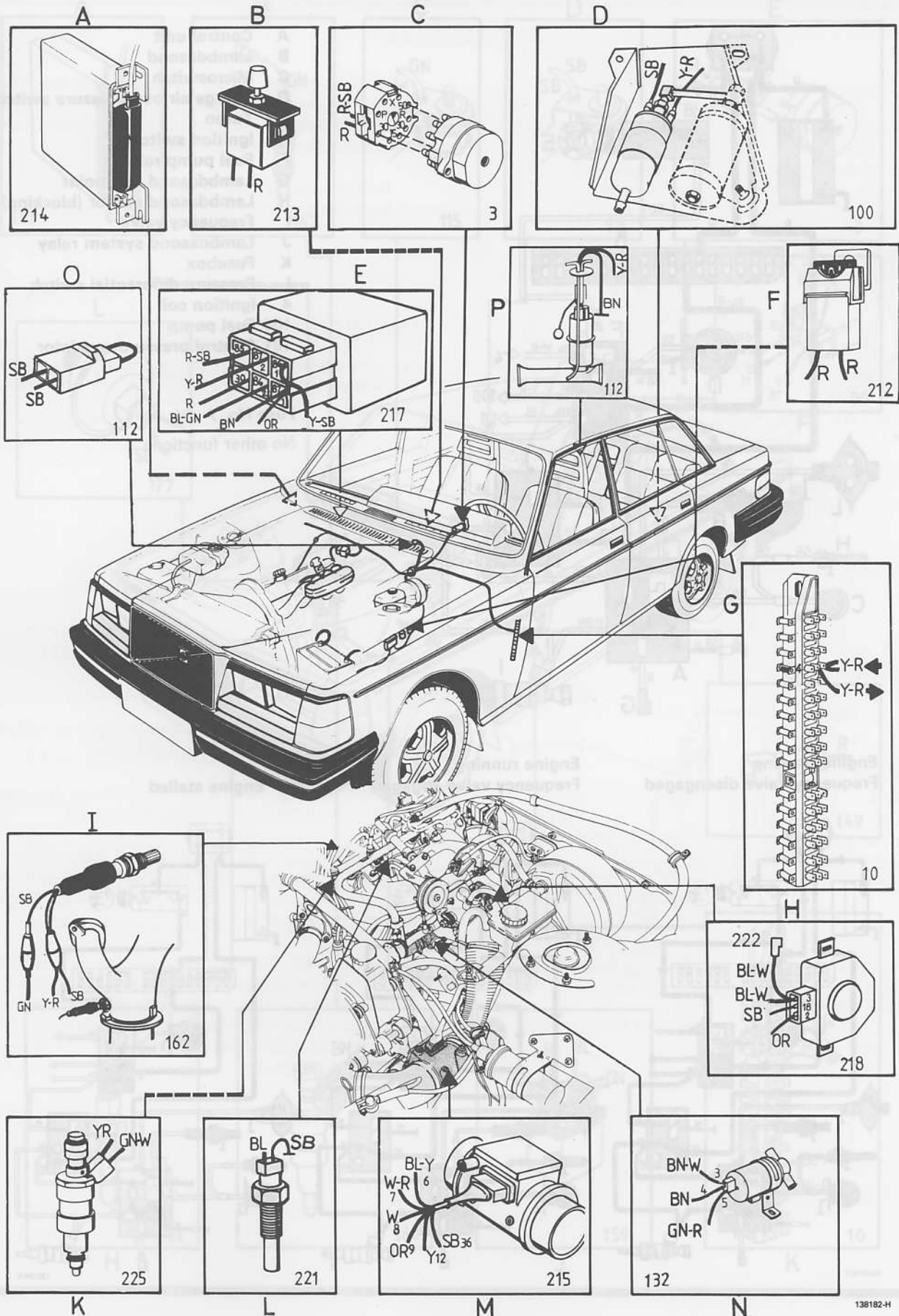

138182-H

LAMBDA SOND WIRING DIAGRAM
B21F Turbo/1985

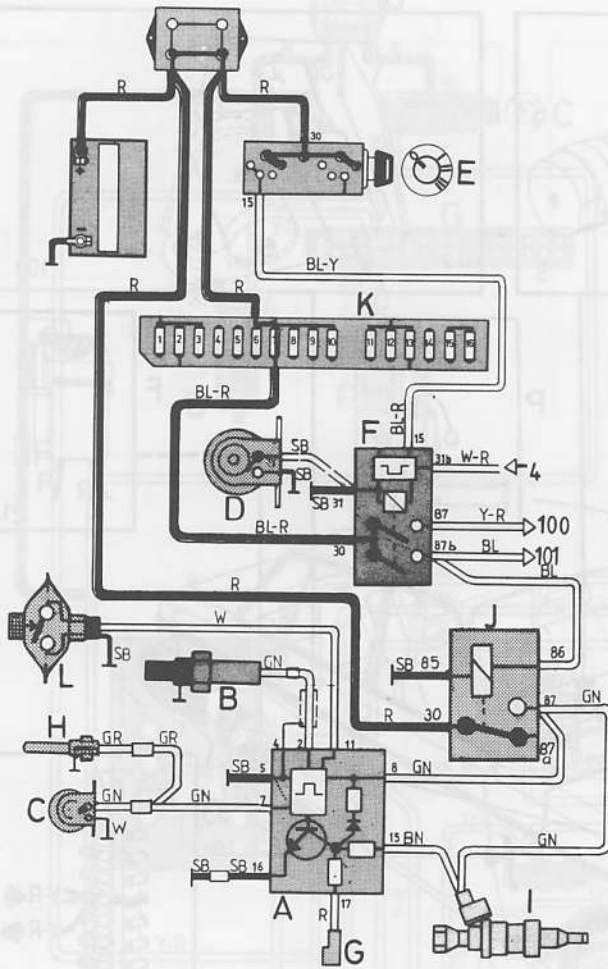

- A Control unit
- B Lambdasond
- C Microswitch
- D Charge air overpressure switch, Turbo
- E Ignition switch
- F Fuel pump relay
- G Lambdasond test point
- H Lambdasond sensor (blocking)
- I Frequency valve
- J Lambdasond system relay
- K Fusebox
- L Pressure differential switch
- 4 ignition coil
- 100 Fuel pump
- 101 Control pressure regulator

Fuse No. 7
No other functions

**Engine running
Frequency valve disengaged**

**Engine running
Frequency valve engaged**

Engine stalled

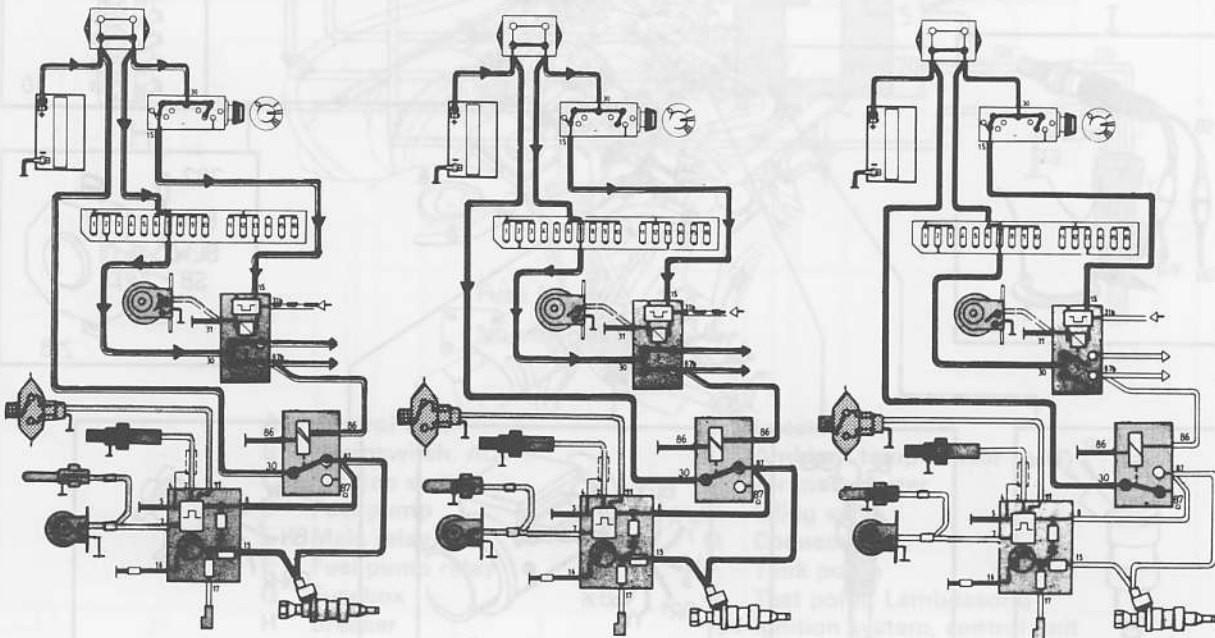

138184-V

LAMBDA SOND COMPONENT PLACEMENT

B21F Turbo/1985

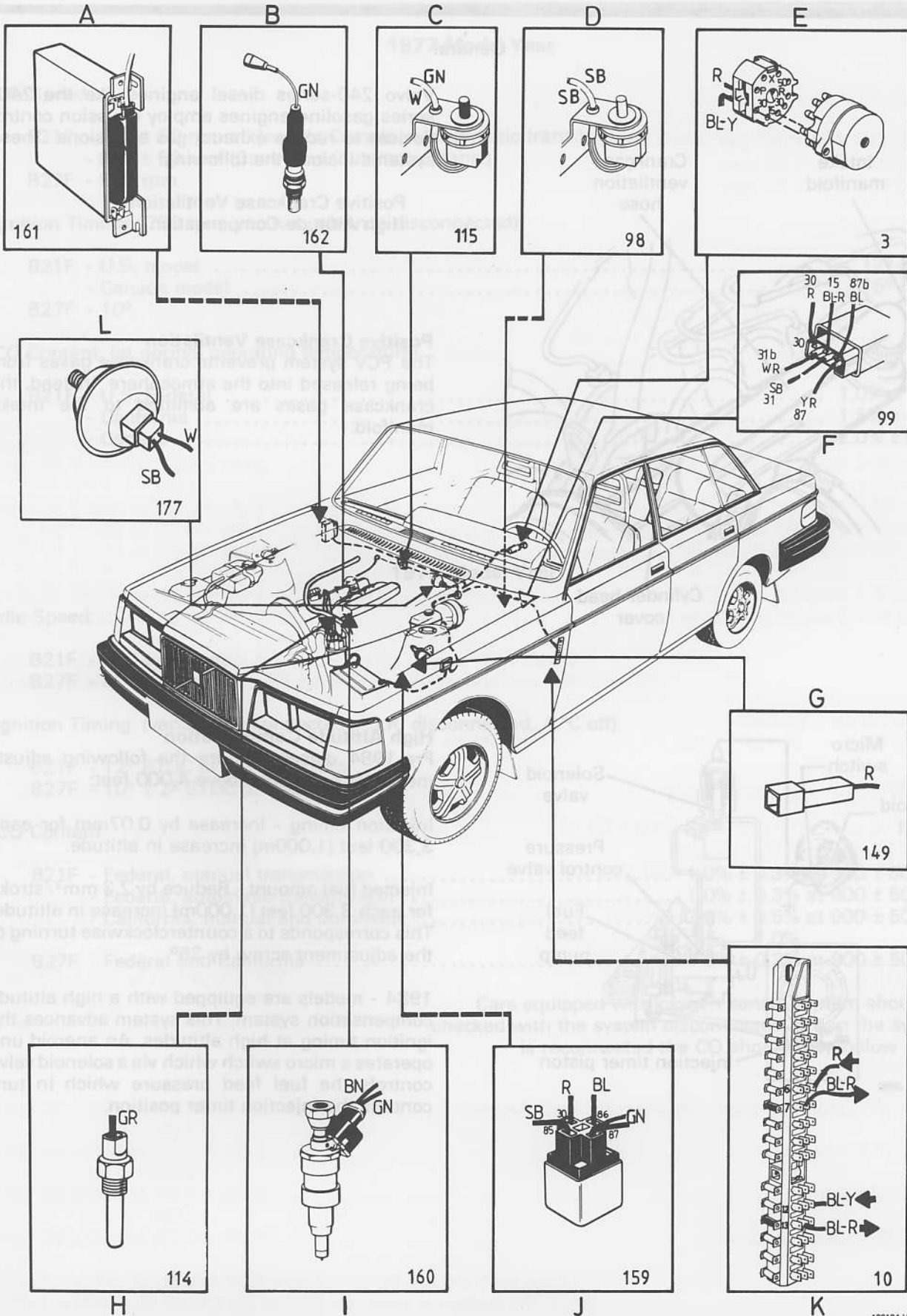

138184-H

DIESEL EMISSION CONTROLS

General

Volvo 240-series diesel engines like the 240-series gasoline engines employ emission control devices to reduce exhaust gas emissions. These systems include the following:

Positive Crankcase Ventilation
High Altitude Compensation

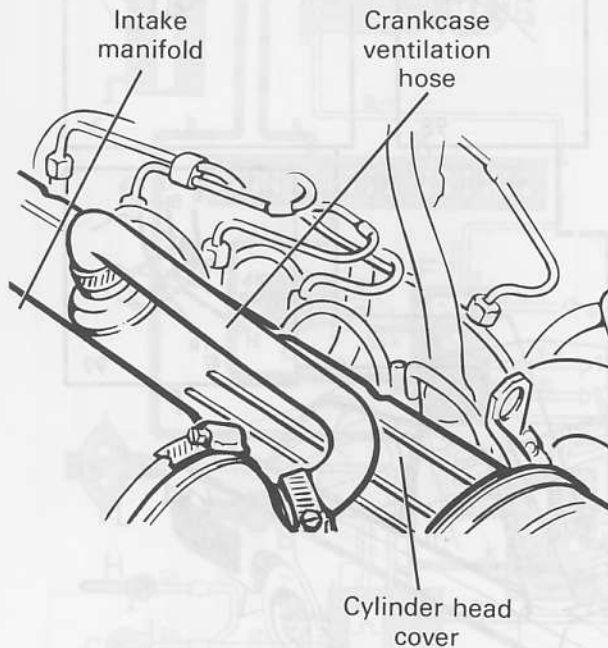

Positive Crankcase Ventilation

The PCV system prevents crankcase gases from being released into the atmosphere. Instead, the crankcase gases are admitted to the intake manifold.

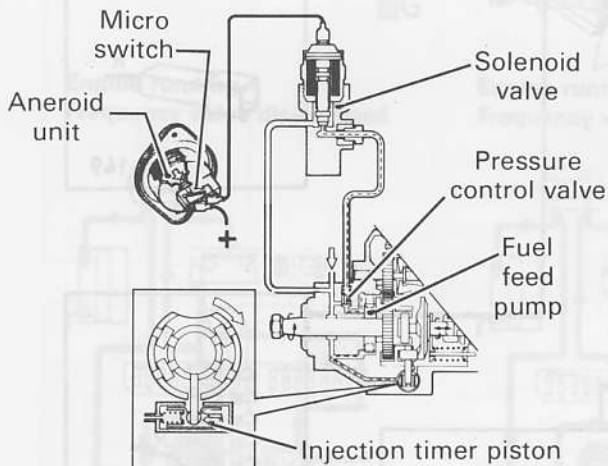

High Altitude Compensation

Pre-1984 diesels require the following adjustments for operation above 4,000 feet:

Injection timing - Increase by 0.07mm for each 3,300 feet (1,000m) increase in altitude.

Injected fuel amount - Reduce by 2.3 mm³/stroke for each 3,300 feet (1,000m) increase in altitude. This corresponds to a counterclockwise turning of the adjustment screw by 35°.

1984 - models are equipped with a high altitude compensation system. This system advances the ignition timing at high altitudes. An aneroid unit operates a micro switch which via a solenoid valve controls the fuel feed pressure which in turn controls the injection timer position.

TUNE UP SPECIFICATIONS

1977 Model Year

Idle Speed:

- B21F - 900 ± 50 rpm all (except Canada w/automatic trans.)
- 850 ± 50 rpm (Canada w/automatic trans.)
- B27F - 900 rpm

Ignition Timing: (750 rpm, vacuum advance disconnected)

- B21F - U.S. model 12° BTDC
- Canada model 15° BTDC
- B27F - 10°

CO Content: (at normal operating temperature)

- B21F - U.S. Federal 1.0% ± 0.3%
- California 1.5% ± 0.3%
- Canada 2.0% ± 0.3%

1978 Model Year

Idle Speed:

- B21F - 900 ± 50 rpm
- B27F - 900 ± 50 rpm

Ignition Timing: (vacuum disconnected, A.I.R. disconnected, A/C off)

- B21F - 12° BTDC at 750 ± 50 rpm
- B27F - 10° ± 2° BTDC at 750 ± 50 rpm

CO Content:

- B21F - Federal, manual transmission 1.0% ± 0.3% at 900 ± 50 rpm
- Federal, automatic transmission 1.0% ± 0.3% at 800 ± 50 rpm
- California, manual and automatic 2.0% ± 0.5% at 900 ± 50 rpm
- 1.0%
- B27F - Federal and California 1.0% ± 0.3% at 900 ± 50 rpm

Cars equipped with oxygen sensor system should be checked with the system disconnected. When the system is reconnected the CO should drop below 1.0%.

-Specifications-

1979 Model Year

Idle Speed:

- B21A - 900 ± 50 rpm
- B21F - 900 ± 50 rpm
- B27F - 900 ± 50 rpm

Ignition Timing:

- B21A - (Canada) 12° ± 2° BTDC at 750 ± 50 rpm
- B21F - USA/Federal and Canada vacuum disconnected, A/C off .. 10° ± 2° BTDC at 750 ± 50 rpm
- B21F - USA/California, A/C off 8° ± 2° BTDC at 750 ± 50 rpm
- B27F - vacuum disconnected, A/C off 10° ± 2° BTDC at 750 ± 50 rpm

CO Content:

- B21A - Canada Pulsair disconnected and plugged 2.5-4% (checking)
3.4% (setting)
- B21F - Canada 2.0% ± 0.5% at 900 ± 50 rpm
1.0%
- B21F - Federal, manual transmission 1.0% ± 0.3% at 900 ± 50 rpm
- B21F - Federal, automatic transmission 1.0% ± 0.3% at 800 ± 50 rpm
- B21F - California, manual and automatic 2.0% ± 0.5% at 900 ± 50 rpm
1.0%
- B27F - Canada 1.0% ± 0.3% at 900 ± 50 rpm
- B27F - Federal and California 1.0% ± 0.3% at 900 ± 50 rpm

Check with oxygen sensor system (Lambda Sond) disconnected.
When the system is reconnected the CO should drop below 1.0%.

1980 Model Year

Idle Speed:

- B21A and B21F (Canada) - 900 ± 50 rpm
- B21F (USA) - 950 ± 50 rpm
- B28F (USA and Canada) - 950 ± 50 rpm

Ignition Timing: (vacuum disconnected, A/C off)

- B21A (Canada) 12° ± 2° BTDC at 750 ± 50 rpm
- B21F (Canada) 10° ± 2° BTDC at 750 ± 50 rpm
- B21F, USA (Federal and California) 8° ± 2° BTDC at 750 ± 50 rpm
- B21F, all 10° ± 2° BTDC at 750 ± 50 rpm

CO Content

- B21A (Canada) (Pulsair disconnected and plugged) 3.5% ± 0.5% at 900 ± 50 rpm
1.0%
- B21F (Canada) 2.0% ± 0.5% at 900 ± 50 rpm
1.0%
- B21F (USA) 2.0% ± 0.5% at 950 ± 50 rpm
1.0%
- B28F - USA and Canada 1.0% ± 0.3% at 950 ± 50 rpm

Check with oxygen sensor system (Lambda Sond) disconnected.
When the system is reconnected the CO should drop below 1.0%.

1981 Model Year

Idle Speed:

On certain models (with Constant Idle Speed System = CIS System) idle speed cannot be adjusted. Controls are sealed.

- B21A (Canada) - 900 rpm \pm 50 rpm
- B23E (Canada) - 900 rpm \pm 50 rpm
- B21F (Federal) - 900 rpm \pm 50 rpm
- B21F (California) - 900 rpm \pm 50 rpm with CIS System
- B21F-MPG - 750 rpm \pm 50 rpm with CIS System
- B21F-Turbo - 900 rpm \pm 50 rpm with CIS System
- B28F (Federal and Canada) - 900 rpm \pm 50 rpm
- B28F (California) - 900 rpm \pm 50 rpm with CIS System

Ignition Timing:

B21A (Canada)	12° \pm 2° BTDC at 750 rpm \pm 50 rpm
B23E (Canada)	5° \pm 2° BTDC at 750 rpm \pm 50 rpm
B21F (Federal)	8° \pm 2° BTDC at 750 rpm \pm 50 rpm
B21F (California)	8° \pm 2° BTDC at 900 rpm \pm 50 rpm
B21F-MPG	12° \pm 2° BTDC at 750 rpm \pm 50 rpm
B21F-Turbo	12° \pm 2° BTDC at 900 rpm \pm 50 rpm
B28F (Federal and Canada)	10° \pm 2° BTDC at 750 rpm \pm 50 rpm
B28F (California)	10° \pm 2° BTDC at 900 rpm \pm 50 rpm

CO Content:

On certain models CO content cannot be adjusted. Controls are sealed.

	CO	Setting Limits	To be set at (\pm 50 rpm)
B21A, Canada (Pulsair and EGR disconnected and plugged)	3.5%	2.5-4.0%	900 rpm
B23E, Canada (Pulsair and EGR disconnected and plugged)	1.0%	0.5-1.0%	900 rpm

Following should be checked with oxygen sensor system (Lambda Sond) disconnected. When the system is reconnected, CO should drop below 1.0%.

B21F, USA (Federal/California)	1.0%	0.7-1.3%	900 rpm
B21F-MPG	1.0%	0.7-1.3%	750 rpm
B21F-Turbo	1.0%	0.7-1.3%	900 rpm
B28F (Canada and USA)	1.0%	0.7-1.3%	900 rpm

-Specifications-

1982 Model Year

Idle Speed:

On USA models (with Constant Idle Speed System = CIS System) idle speed cannot be adjusted. Controls are sealed.

- B21A (Canada) - 900 rpm \pm 50 rpm
- B23E (Canada) - 900 rpm \pm 50 rpm
- B21F - 750 rpm \pm 20 rpm
- B21F LH-Jetronic - 750 rpm \pm 20 rpm
- B21F-Turbo - 900 rpm \pm 50 rpm
- B28F (USA and Canada) - 900 rpm \pm 20 rpm

On B21F and B21F LH-Jetronic with idle speed 750 rpm, idle speed increases to 900 rpm when AC is switched on.

Ignition Timing:

To be set at idle.

B21A (Canada)	7° \pm 2° BTDC
B23E (Canada)	5° \pm 2° BTDC
B21F	12° \pm 2° BTDC
B21F LH-Jetronic	12° \pm 2° BTDC
B21F-Turbo	12° \pm 2° BTDC
B28F (USA and Canada)	10° \pm 2° BTDC

CO Content:

CO should be set within three minutes after thermostat opens.
 On USA models CO content cannot be adjusted. Controls are sealed.

	CO	Setting Limits
B21A (Canada) (Pulsair and EGR disconnected and plugged)	3.0%	2.5-4.0%
B23E (Canada) (Pulsair and EGR disconnected and plugged)	1.0%	0.5-2.0%

Following should be checked with oxygen sensor system disconnected.
 When system is reconnected, CO should drop below 1.0%.

B21 (CI)	1.0%	0.7-1.3%
B21F LH-Jetronic	0.6%	0.4-0.8%
B21F-Turbo	1.0%	0.7-1.3%
B28F	1.0%	0.7-1.3%

CO Content

B21A (Canada) (Pulsair disconnected and plugged)	3.5% \pm 0.5% at 900 \pm 50 rpm
B21F (Canada)	2.0% \pm 0.5% at 900 \pm 50 rpm
B21F (USA)	2.0% \pm 0.5% at 950 \pm 50 rpm
B28F - USA and Canada	1.0% \pm 0.3% at 950 \pm 50 rpm

Check with oxygen sensor system (Lambda Sond) disconnected.
 When the system is reconnected the CO should drop below 1.0%.

1983 - 1985 Model Year

Idle Speed:

- B21A - 900 rpm ± 50 rpm
- B23E - 900 rpm ± 50 rpm
- B21F-Turbo - 900 rpm ± 50 rpm
- B23F - 750 rpm ± 20 rpm

Ignition Timing:

Vacuum units disconnected, air conditioning off.

- B21A 7° BTDC at 750 rpm
- B21F-Turbo 12° BTDC at 900 rpm
- B23E 10° BTDC at 750 rpm
- B23F 12° BTDC at 750 rpm

Start engine and do not run it over 1500 rpm (to avoid influence from Spark Control Unit).

CO Content:

	CO	Setting Limits
B21A	3.0%	2.5-4.0%
B23E	1.0%	0.5-2.0%
B21F-Turbo	1.0%	0.7-1.3%
B23F	0.6%	0.4-0.8%

Idle Speed

Idle Speed

Idle Speed

On USA models (with Constant Idle Speed System or CIS System) idle speed is controlled by the engine control system. Controls are sealed.

B21A (Canada) - 900 rpm \pm 50 rpm

B23E (Canada) - 900 rpm \pm 50 rpm

B21F - 750 rpm \pm 20 rpm

B21F LH-Jetronic - 750 rpm \pm 20 rpm

B21F Turbo - 900 rpm \pm 50 rpm

B23F (USA and Canada) - 900 rpm \pm 20 rpm

Ignition Timing

Vacuum units disconnected, air conditioning off

B21A	15° BTDC at 750 rpm
B23E	12° BTDC at 900 rpm
B23F	10° BTDC at 750 rpm
B23F	13° BTDC at 750 rpm

Start engine and do not run it over 1500 rpm (to avoid influence from Spark Control Unit)

Idle speed at idle

CO Content

B21A (Canada)	0.8-1.0%
B23E (Canada)	0.8-1.0%
B21F LH-Jetronic	0.8-1.0%
B21F Turbo	0.8-1.0%
B23F (USA and Canada)	0.8-1.0%
B23F	0.8-1.0%

CO should be set within three minutes after thermostat opens.

On USA models CO content cannot be adjusted. Controls are sealed.

CO Setting Units

B21A (Canada) (Pulsar and EGR disconnected and plugged)	0.0%	2.5-4.0%
B23E (Canada) (Pulsar and EGR disconnected and plugged)	0.0%	2.5-4.0%

Following should be checked with oxygen sensor system disconnected

When system is reconnected, CO should drop below 1.0%

B21 (CI)	1.0%	0.7-1.3%
B21F LH-Jetronic	0.8%	0.4-0.8%
B21F Turbo	1.0%	0.7-1.3%
B23F	1.0%	0.7-1.3%



VOLVO SUPPORTS VOLUNTARY
MECHANIC CERTIFICATION
BY THE N.A.S.E.
(USA ONLY)

Service literature

*Your
most important
special tool*



**VOLVO SUPPORTS VOLUNTARY
MECHANIC CERTIFICATION
BY THE N.I.A.S.E.
(USA ONLY)**

Service literature

*Your
most important
special tool*

VOLVO

TP 30727/1

2000.9.85

Printed in U.S.A.